



**Conscious** of the importance of the Sava River for the economic, social and cultural development of the region,

**Desirous** of development of the inland navigation on the Sava River,

**Having regard** to the European Agreement on Main Inland Waterways of International Importance (AGN), and in particular Annex III thereof,

**Believing** that public authorities can contribute significantly to the development of the waterway of the Sava river through their engagement to the provision and maintenance of an appropriate waterway based on internationally agreed classifications and parameters,

**In accordance with** Article 16 Paragraph 1 (a) and 2 of the Framework Agreement of the Sava River Basin and Article 9 Paragraph 4 of the Protocol on the Navigation Regime to the Framework Agreement of the Sava River Basin, the International Sava River Basin Commission (hereinafter: Sava Commission) on its VIII Special Session held on November 12-13, 2007, has adopted the following

### **DECISION – 31/07**

on adoption of

### **RULES FOR WATERWAY MARKING ON THE SAVA RIVER BASIN**

1. Text of the Rules for Waterway Marking on the Sava River Basin is attached to this Decision as its integral part.
2. Parties shall adopt the measures necessary to implement this Decision and notify the Sava Commission.
3. This Decision shall be binding for the Parties unless any of the Sava Commission members withdraws his or her vote within 30 days after the decision has been adopted, or informs the Sava Commission that the Decision is subject to the approval of the relevant authority of his State.

If any of the Sava Commission members withdraws his or her vote within 30 days after the decision has been adopted, or informs the Sava Commission that the Decision is subject to the approval of the relevant authority of his State, the

Sava Commission Secretariat shall, thereof, inform all other Sava Commission members.

4. If no member withdraws his vote nor informs the Sava Commission that the Decision is subject to the approval of the relevant authority of his State, the Decision shall enter into force on December 13, 2007.
5. Upon entry into force, this Decision shall be binding in its entirety and directly applicable in the Parties.
6. The Sava Commission Secretariat shall notify the Parties of the entry into force of the Decision.

Ref. No: 1S-8-D-07-7/1-3

**Zagreb, November 13, 2007**

**Mr. Kemal Karkin**  
**Chairman of the Sava Commission**

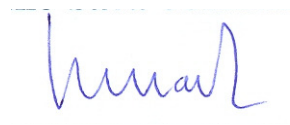



**Conscious** of the importance of the Sava River for the economic, social and cultural development of the region,

**Desirous** of development of the inland navigation on the Sava River,

**Having regard** to the UNECE Resolution 59 revised on Guidelines for Waterway Signs and Markings,

**Believing** that public authorities can contribute significantly to the development of the waterway of the Sava river through their engagement to the provision and maintenance of an appropriate waterway system based on internationally agreed rules,

**In accordance** with Article 16 Paragraph 1 (a) and 2 of the Framework Agreement on the Sava River Basin and Article 9 Paragraph 2 of the Protocol on the Navigation Regime to the Framework Agreement on the Sava River Basin, the International Sava River Basin Commission (hereinafter: ISRBC) at its 31<sup>st</sup> Session held on February 20, 2013, has adopted the following

## **DECISION – 02/13**

**on adoption of**

### **AMENDMENTS TO THE DECISION 31/07 ON ADOPTION OF RULES FOR WATERWAY MARKING IN THE SAVA RIVER BASIN**

7. Text of the Amendments to the Decision 31/07 on adoption of the Rules for Waterway marking in the Sava River Basin and Consolidated text of Rules for Waterway Marking in the Sava River Basin are attached to this Decision as its integral part.
8. Parties shall adopt the measures necessary to implement this Decision and notify the ISRBC.
9. This Decision shall be binding for the Parties unless any of the ISRBC members withdraws his vote within 30 days after the decision has been adopted, or informs the ISRBC that the Decision is subject to the approval of the relevant authority of his State.

If any of the ISRBC members withdraws his vote within 30 days after the decision has been adopted, or informs the ISRBC that the Decision is subject to the approval of the relevant authority of his State, the ISRBC Secretariat shall, thereof, inform all other ISRBC members.

10. If no member withdraws his vote nor informs the ISRBC that the Decision is subject to the approval of the relevant authority of his State, the Decision shall enter into force on March 20, 2013.
11. Upon entry into force, this Decision shall be binding in its entirety and directly applicable in the Parties.
12. The ISRBC Secretariat shall notify the Parties of the entry into force of the Decision.

Ref. No: 1S-31-D-13-6/1-2  
**Belgrade, February 20, 2013**

Mr. Miodrag Pješčić  
Chairman of the ISRBC

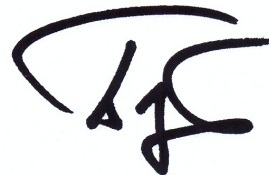



**Conscious** of the importance of the Sava River for the economic, social and cultural development of the region,

**Desirous** of development of the inland navigation on the Sava River,

**Having regard** to the UNECE Resolution 59 revised on Guidelines for Waterway Signs and Markings,

**Believing** that public authorities can contribute significantly to the development of the waterway of the Sava river through their engagement to the provision and maintenance of an appropriate waterway system based on internationally agreed rules,

**In accordance** with Article 16 Paragraph 1 (a) and 2 of the Framework Agreement on the Sava River Basin and Article 9 Paragraph 4 of the Protocol on the Navigation Regime to the Framework Agreement on the Sava River Basin, the International Sava River Basin Commission (hereinafter: ISRBC) at its 36<sup>th</sup> Session held on October 14, 2014, has adopted the following

## **DECISION – 15/14**

### **on adoption of**

### **AMENDMENTS TO THE DECISION 02/13 ON ADOPTION OF RULES FOR WATERWAY MARKING IN THE SAVA RIVER BASIN**

13. Text of the Amendments to the Decision 02/13 on adoption of the Rules for Waterway marking in the Sava River Basin and Consolidated text of Rules for Waterway Marking in the Sava River Basin are attached to this Decision as its integral part.
14. Parties shall adopt the measures necessary to implement this Decision and notify the ISRBC.
15. This Decision shall be binding for the Parties unless any of the ISRBC members withdraws his vote within 30 days after the decision has been adopted, or informs the ISRBC that the Decision is subject to the approval of the relevant authority of his State.

If any of the ISRBC members withdraws his vote within 30 days after the

decision has been adopted, or informs the ISRBC that the Decision is subject to the approval of the relevant authority of his State, the ISRBC Secretariat shall, thereof, inform all other ISRBC members.

16. If no member withdraws his vote nor informs the ISRBC that the Decision is subject to the approval of the relevant authority of his State, the Decision shall enter into force on November 14, 2014.
17. Upon entry into force, this Decision shall be binding in its entirety and directly applicable in the Parties.
18. The ISRBC Secretariat shall notify the Parties of the entry into force of the Decision.

Ref. No: 1S-36-D-14-2/1-2  
**Zagreb, October 14, 2014**

**Mitja Bricelj**  
**Chairman of the ISRBC**





Ref. No: IR-50-D-18-3/1-2

**Conscious** of the importance of the Sava River for the economic, social and cultural development of the region,

**Desirous** of development of the inland navigation on the Sava River,

**Having regard** to the European Agreement on Main Inland Waterways of International Importance (AGN), and in particular Annex III thereof,

**Believing** that public authorities can contribute significantly to the development of the waterway of the Sava river through their engagement to the provision and maintenance of an appropriate waterway based on internationally agreed classifications and parameters,

**In accordance** with Article 16 Paragraph 1 (a) and 2 of the Framework Agreement of the Sava River Basin and Article 9 Paragraph 1 of the Protocol on the Navigation Regime to the Framework Agreement of the Sava River Basin, the International Sava River Basin Commission (hereinafter: Sava Commission), has adopted the following

## **DECISION – 13/18**

**on adoption of the**

### **AMENDMENTS TO THE DECISION 15/14 ON ADOPTION OF RULES FOR WATERWAY MARKING IN THE SAVA RIVER BASIN**

1. Text of the Amendments to the Decision 15/14 on adoption of the Rules for Waterway marking in the Sava River Basin and Consolidated text of Rules for Waterway Marking in the Sava River Basin are attached to this Decision as its integral part.
2. Parties of the Framework Agreement shall adopt the measures necessary to implement this Decision and notify the Sava Commission thereof.

3. This Decision shall be binding for the Parties of the Framework Agreement unless any of the Sava Commission members withdraws his vote within 30 days after the decision has been adopted, or informs the Sava Commission that the Decision is subject to the approval of the relevant Master Office of his State.

If any of the Sava Commission members withdraws his or her vote within 30 days after the decision has been adopted, or informs the Sava Commission that the Decision is subject to the approval of the relevant authority of his or her State, the Sava Commission Secretariat shall, thereof, inform all other Sava Commission members.

4. If no member withdraws his or her vote nor informs the Sava Commission that the Decision is subject to the approval of the relevant authority of his or her State, the Decision shall enter into force on January 5, 2019.
5. Upon entry into force, this Decision shall be binding in its entirety and directly applicable in the Parties of the Framework Agreement.
6. The Sava Commission Secretariat shall notify the Parties of the Framework Agreement of the entry into force of the Decision.

**Zagreb, December 5, 2018**

**Mr. Igor Pejić**

**Chairman of the Sava Commission**







**RULES FOR WATERWAY MARKING  
IN THE SAVA RIVER BASIN**  
*(consolidated text based on  
Decisions 31/07, 02/13, 15/14 and 13/18)*

**Zagreb, 2018**

**CONTENT**

- CHAPTER 1 GENERAL..... 12**
  
- CHAPTER 2 REQUIREMENTS TO BE MET BY SIGNS AND MARKS AND THEIR MARKING PLAN ..... 13**
  
- CHAPTER 3 VISIBILITY OF SIGNS AND LIGHTS..... 15**
  - Conditions of visibility and dimensions of signs ..... 16
  - Conditions for the visibility of lights ..... 18
  - Obligation not to hinder road and rail traffic ..... 18
  
- CHAPTER 4 INSTALLATION OF SIGNS AND MARKING IN CHARACTERISTIC SECTIONS OF THE RIVER..... 19**
  - General..... 19
  - Marking of meandering sectors ..... 21
    - Installation of cross-over marks and bank lights ..... 21
    - Installation of floating signs ..... 25
  - Marking of shoals..... 26
  - Marking of the vicinity of bridges and passages through bridges ..... 28
  - Marking of the winter harbours and winter shelters..... 30
  - Installation of floating signs and restricting the berthing points ..... 31
  - Reference numbers on buoys and markers ..... 31
  
- CHAPTER 5 VARIABLE MESSAGE SIGNS TO REGULATE TRAFFIC..... 31**
  
- CHAPTER 6 INSTALLATION OF RADAR REFLECTORS ON MARKING SIGNS AND SIGNALS AND NAVIGABLE PASSES THROUGH BRIDGES ..... 32**
  
- ANNEX 1 MINIMAL DIMENSIONS OF THE SIGNS FROM ANNEX 7 AND 8 OF THE CEVNI..... 34**
  - 1. Visibility of navigation signs ..... 34
  - 2. Minimal dimensions of the signs contained in annex 7 to the European Code for Inland Waterways.... 36
  - Section I: Main signs..... 36
    - A. Prohibitory signs ..... 36
    - B. Mandatory signs ..... 58

<b>C. Restrictive signs .....</b>	<b>73</b>
<b>D. Recommndatory sighs .....</b>	<b>81</b>
<b>E. Informative signs .....</b>	<b>86</b>
<b>Section II: Auxiliary signs .....</b>	<b>136</b>
<b>Section II.1 Panels showing the distance at which the regulation applies or the special feature indicated by the main sign is to be found .....</b>	<b>136</b>
<b>Section II.3 Pointers showing the direction of the section to which the main sign applies .....</b>	<b>138</b>
<b>Section II.4 Panels giving explanations or additional information .....</b>	<b>139</b>
<b>3. Minimal dimensions of the signs contained in annex 8 to the Navigation rules in the Sava river basin</b>	<b>140</b>
<b>3.1 Buoyage of fairway limits in the waterway.....</b>	<b>140</b>
<b>3.2 Bank marks indicating the position of the fairway .....</b>	<b>143</b>
<b>3.3 Buoyage and marking of danger points and obstacles.....</b>	<b>149</b>
<b>3.4 Radar reflectors on marking signs and signals and navigable passes through bridges .....</b>	<b>157</b>
<b>ANNEX 2 PROPERTIES OF LIGHTS .....</b>	<b>159</b>
<b>ANNEX 3 COLOURS OF REFLECTED LIGHT FOR NAVIGATION SIGNS .....</b>	<b>162</b>
<b>ANNEX 4 RECOMMENDATIONS FOR THE LIGHTING OF TRAFFIC SIGNS ....</b>	<b>165</b>
<b>ANNEX 5 EXAMPLES FOR VARIABLE-MESSAGE TRAFFIC SIGNS .....</b>	<b>168</b>

# **Chapter 1**

## **GENERAL**

### **Article 1.0**

The present Rules shall be applied on the waterways on the Sava River from the river kilometer 0.00 to the river kilometer 586.00, on the Kolubara River from the river kilometer 0.00 to the river kilometer 5.00, on the Drina River from the river kilometer 0.00 to the river kilometer 15.00, on the Bosna River from the river kilometer 0.00 to the river kilometer 5.00, on the Vrbas River from the river kilometer 0.00 to the river kilometer 3.00, on the Una River from the river kilometer 0.00 to the river kilometer 15.00 and on the Kupa River from the river kilometer 0.00 to the river kilometer 5.00.

### **Article 1.1**

In terms of the objective pursued, the marking comprises two categories of signs:

- (a) Signs used to regulate navigation on the waterway, set out in Annex 7 to the Navigation Rules on the Sava River Basin, and
- (b) Signs and signals installed on the waterway (hereafter floating signs) and signs installed on the banks (hereafter bank marks) marking the sides of the fairway and navigational hazards, set out in Annex 8 to the Navigation Rules in the Sava River Basin.

Besides these marks, the competent authorities, referred to in Article 1.9 of these regulations, are obliged to set kilometre marks along the waterway when it is possible in relation to the dimensions of the fairway, and to preferably mark every hundred meters.

### **Article 1.2**

The signs set out in Annex 7 to the Navigation Rules on the Sava River Basin are prohibitory, mandatory, restrictive, recommendatory or informative signs and auxiliary signs.

### **Article 1.3**

In accordance with article 5.01 to the Navigation Rules on the Sava River Basin, vessels' crew members shall obey the requirements and take into account the recommendations or indications brought to their attention by these signs.

### **Article 1.4**

Floating signs and bank marks of Annex 8 to the Navigation Rules on the Sava River Basin are used to indicate the limits, the direction and the depth of the fairway and, in addition, to mark obstacles and permanent structures on the fairway or its vicinity. Here, the instructions of Section A of Chapter I, annex 8 to the Navigation Rules in the Sava River Basin shall be taken into account.

### **Article 1.5**

The number of signs, bank marks, floating signs and their on-site location shall meet the requirements of navigational safety.

### **Article 1.6**

The choice of the marks and the establishment of their number depends on the local characteristics of the fairway and the function of the mark. Their installation shall be effected in cases when it is required by navigation criteria on the respective river section, in such a way as to ensure visibility from one mark to the next.

### **Article 1.7**

The luminous range of lights is established by the competent authorities of the respective countries in terms of local navigational conditions. In classifying the luminous intensity, it is recommended to use the

classification of luminous intensity in annex 2 to the present Rules, which also includes calculations for luminous range.

#### **Article 1.8**

In principle, the colours of lights should be kept with the standard of the International Commission on Illumination (CIE “Colours of light signals” S 004/E-2001, class A).

#### **Article 1.9**

The marks shall be installed by the competent authorities which:

- (a) regularly observe the state of the river bed and the changes taking place in it and, on the basis of the results of these observations, correct the positioning of the signs and marks and, where necessary, add to them so that they will indicate the fairway dimensions;
- (b) regularly measure the depth and the width of the marked fairway and provide boatmasters with the necessary information concerning the minimum fairway depths and widths and the river level regime;
- (c) establish the plan for the installation of signs and marks (hereinafter the marking plan) in their respective sectors and establish the type and number of floating signs and bank marks to be used, in terms of the requirements of navigational safety and local conditions;
- (d) ensure as far as possible the uninterrupted operation of all floating signs and bank marks;
- (e) Inform boatmasters in a good time of the date of the installation and removal of signs, of all alterations of importance to navigation to their number, type, positioning and lighting, and the rules they establish permitting the passage of vessels in restricted sections where meeting and passing are prohibited.

## **Chapter 2**

### **REQUIREMENTS TO BE MET BY SIGNS AND MARKS AND THEIR MARKING PLAN**

#### **Article 2.1**

The marking shall be continuously (by day and by night) in operation all along the navigable section of the river, and, as far as possible, as from when the waterway is free from ice until the ice appears; it shall be corrected as changes occur in the waterlevel and in the fairway.

In accordance with the state of the fairway, marking system shall be positioned in such a way that the vessels sailing downstream can use the part of the river with high flow velocities, while the vessels sailing upstream can use the part of the river with low flow velocities.

#### **Article 2.2**

During periods of high water and icing, the regular floating signs, removed to be preserve from possible damage, shall be replaced, as far as possible, by marker posts and spars, the topmarks and colours of which shall correspond to those adopted for the respective side of the fairway.

#### **Article 2.3**

Floating signs shall be installed so as to ensure the safety of vessels in the fairway.

#### **Article 2.4**

Buoys shall be unsinkable and shall remain unsinkable in all storms, and their main body shall therefore be watertight; they shall not only float but also be stable, i.e. keep a vertical position as far as possible and not be tipped excessively by waves and wind.

### **Article 2.5**

The basic condition that the marking plan shall meet is to ensure the safety of the vessels and the continuity of traffic, by day and by night, throughout the sailing season and to give boatmasters clear and unambiguous indications concerning the direction and the limits of the fairway.

### **Article 2.6**

The marking plan shall be prepared in such a way as to permit a rational combination of bank marks and floating signs. When the plan is drawn up, it should be based on the conditions of navigation and specific hydrographic and hydro-meteorological conditions, the need to ensure the established dimensions of the fairway and create the necessary conditions for the safety and continuity of navigation of all river vessels and, where necessary, of seagoing vessels.

### **Article 2.7**

Bank marks serve to guide the boatmasters and to indicate the direction of the fairway. Floating signs supplement the bank marks in sectors where, in order to ensure the safety of navigation, it is essential to indicate not only the direction of the fairway but also its limits, and to mark places where there are obstacles.

### **Article 2.8**

In preparing the marking plan, the following requirements should be taken into account:

- (a) Only the signs set out in Annexes 7 and 8 to the Navigation Rules in the Sava River Basin are to be used to mark the fairway and regulate navigation; in exceptional cases, special additional bank marks may also be used, provided, however, that the marks are not in contradiction with those contained in the Navigation Rules in the Sava River Basin;
- (b) The dimensions of the marked fairway shall correspond to the dimensions published by the competent authorities;
- (c) The choice of where the signs are to be placed shall be based on the most recent measurements, acquired experience and available data on the state of the fairway, critical points, water levels, etc.;
- (d) Signs and marker lights shall be visible, whatever the level of the water, at all points of the fairway and as long as may be necessary for the guidance of boatmasters.
- (e) The marking plan shall contain information on type of the placed signs, bank/side whereon placed, river kilometre of the set-up and recapitulation of all floating signs and bank signs used for marking.

### **Article 2.9**

If there is a subsequent drop in the level of the water, reconnaissance soundings shall be taken on some sections of the river in order to check whether the positioning of the signs is adequate and to establish whether the marking needs to be supplemented by new signs.

### **Article 2.10**

The frequency of these soundings shall be determined by changes in water level. The more rapid the drop in levels, the more frequent soundings need to be.

## **Chapter 3**

### **VISIBILITY OF SIGNS AND LIGHTS**

#### **Article 3.1**

Whatever the position of the vessel in relation to the sign or the marker light, the characteristics of the sign or light shall remain unchanged. For daytime signs, these characteristics are: the form (topmark) and the colour; for signs at night: the type and colour of the lights.

#### **Article 3.2**

The forms and the colours of the topmarks and the types and colours of the lights are set out in detail in Annexes 7 and 8 to the Navigation Rules on the Sava River Basin.

#### **Article 3.3**

Sketches of the signs and marks with the minimal dimensions are given in the Annex 1 to these Rules. The numbering of the sketches corresponds to the numbering of the signs and marks given in Annexes 7 and 8 to the Navigation Rules on the Sava River Basin.

#### **Article 3.4**

The basic requirement to be met by signs and marking is the guarantee of good visibility of all signs and lights by day or night.

#### **Article 3.5**

In accordance with the recommendations of the International Association of Marine Aids to Navigation and Lighthouse Authorities (IALA)<sup>1</sup>, there are three degrees of visibility of signs:

- (a) First: the sign is visible to the naked eye. The meaning of the sign is not yet identifiable (simply visible);
- (b) Second: when the sign is clearly visible and identifiable according to Navigation Rules in the Sava River Basin (identifiable);
- (c) Third: the sign is identifiable and distinguishable from its surrounding background (conspicuous).

Signs that must be seen by a boatmaster at some imperative distance (“no entry”, “keep a particular sharp lookout”, etc.) must be of the visibility (due to their proper dimensions) of second or third degree. The type and dimensions of signs should be selected accordingly.

Third degree visibility is required when the sign or light is identifiable in principle, but cannot be easily seen at night owing to the surrounding background (presence of construction or a large number of light sources).

#### **Article 3.6**

The degree of visibility of signs and lights, depends on the following conditions:

Signs:

- Angle of sight;
- Colour contrast and differences;
- Lighting (including natural day light) and weather conditions.

Lights:

---

<sup>1</sup> IALA Guideline No. 1094 On Daymarks for Aids to Navigation, Edition 1, December 2012.

- Luminous intensity;
- Competing lights and background lighting;
- Weather conditions.

### Conditions of visibility and dimensions of signs

#### Article 3.7

In order to ensure the first degree visibility, in daytime the sign shall be visible with an angle of more than 1 angular minute and with sufficient contrast in relation to the environment. Detailed form and colour of the sign (second and third degree visibility) can only be distinguished with a larger angle of sight or with a reduction in the distance L to the object being observed.

#### Article 3.8

The minimal angle of distinction in daytime for simple shapes (cylinder, cone, sphere etc.) is between 3 and 5 angular minutes, and for complex shapes (numbers, letters, etc.) between 5 and 8 angular minutes. For the boatmaster to be able to recognize the daymark (without any optical aids) at appropriate distances and visibility, the following formula can be used for the calculation of the required minimum dimensions of simple and complex shapes:

$$H = L \cdot \operatorname{tg} \alpha \cong L \cdot \sin \alpha$$

H (m) – height of the sign;

L (m) – distance;

$\alpha$  (°) – viewing angle

Figure 1a

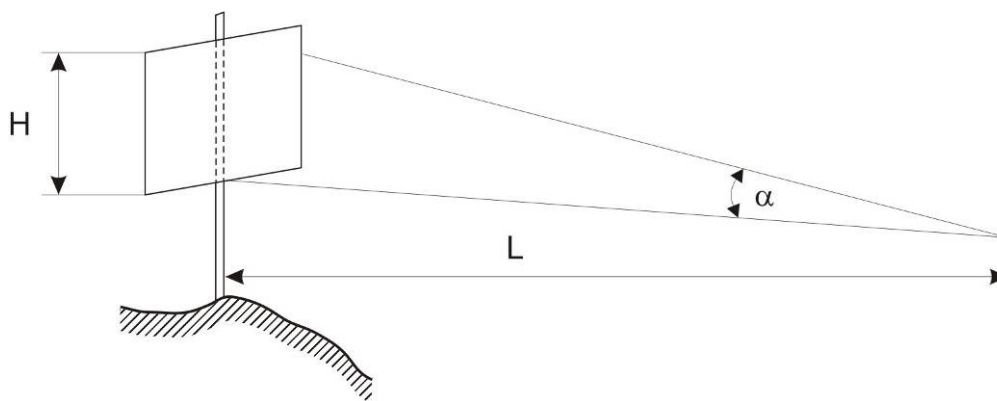

Values for H (m) in function of L(m) and  $\alpha$ (°) are presented in the Table 1.



**Table 1:**

For signs of simple shapes (quadrant, triangle, circle, etc.)	L(m) \ $\alpha$ (°)	500	1000	2000	3000	4000
	3	0.44	0.87	1.74	2.61	3.48
4	0.58	1.16	2.32	3.48	4.64	
5	0.73	1.45	2.90	4.35	5.80	

Table 1 shows that the shape of a sign with dimension  $H = 0.5$  m is recognizable at distance  $L = 500$ m and viewing angle  $\alpha = 4^\circ$ ; when  $L = 1000$ m, then  $H = 1$ m, etc.

When there are simple drawings (dot, line, arrow) on the signs, a 15 percent visibility reduction must be taken into account, while with complex drawings it shall be 30 percent.

### Article 3.9

Examples of the minimum measurements for the signs, marks and buoys from Annexes 7 and 8 to Navigation Rules in the Sava River Basin are given in Annex 1 to these Rules. Alphanumeric characters on signs should intend to provide a standard for the various signs.

The letters, figures and analogous symbols should be of a height not less than one five-hundredth of the maximum distance from which they must be read, and the thickness of the stroke should be not less than one seventh of that height<sup>2/</sup>.

For bank marks and signs, the minimal height of the lower rim of the board down to the base of the lowest sign shall be 3 m. In places where it is necessary due to configuration of the terrain (relief), the height of 2 m is allowed. At the highest navigation water levels, the height between the water surface the lower rim of the board of the lowest sign should not be less than 1.5 m.<sup>3</sup>

### Article 3.10

As regards the signs and signals of Annex 7 and Annex 8 to the Navigation Rules on the Sava River Basin, unlighted buoys and unlighted bank mark boards shall be covered with reflective material. Light buoys and lighted bank mark boards may also be so covered. The colours of these materials shall correspond to those established for the buoy lights or the boards. In all cases, the topmarks of light buoys shall be covered with reflective paint.

### Article 3.11

In order to ensure that bank marks are clearly visible, their dimensions shall be determined in terms of their purpose, the distance between the fairway and the banks, the nature of the region and the characteristics or other specific conditions of the sector in question.

### Article 3.12

The good visibility of a sign or signal depends on the contrast between the luminance of the sign or signal and the background. This shall be taken into consideration in choosing a site for signs. For example, of two boards, one red and the other white, positioned one beside the other against a light background, the red

<sup>2/</sup> This provision is taken from the Resolution N° 22 "SIGNI – Marks and signs on inland waterways" (ECE/TRANS/SC.3/108/Rev.2), hereinafter - SIGNI.

<sup>3</sup> If this requirement cannot be met due to local conditions, the competent authorities may prescribe other requirements to ensure proper visibility

board will be more visible and visible at a greater distance than the white board while, in contrast, the white board will be easier to see than the red board against a dark background.

#### **Article 3.13**

The visibility of signs of Annexes 7 and 8 of Navigation Rules on the Sava River Basin regulating navigation on the waterway shall be ensured at night by lighting them with fixed directional white lights, operating uninterruptedly and positioned so that the light does not incommode the boatmasters.<sup>4/</sup>

If electric lighting cannot be used, the sign boards shall be covered with reflective material of a corresponding colour on which the symbol shall be clearly visible to vessels.

#### **Article 3.14**

In order to guarantee the visibility of lighted boards, the back lighting must conform with the provisions of annex 4, where, in addition to luminance and its regularity, the colour for the white light source is established to ensure that colours under artificial light look the same as when seen in daylight.

For reliable identification at night the surface of the sign must be smooth and even, and if possible reflective.

### **Conditions for the visibility of lights**

#### **Article 3.15**

In certain cases lighting may be provided at night (e.g. lighting of the lower part of a bridge, of the piers of a bridge, of the approaches to a lock, of a section of a canal, etc.). Such lighting may be used to supplement the markings. Lighting shall be so designed as to avoid dazzling.<sup>5</sup>

#### **Article 3.16**

Luminous intensity is broken down into three categories in terms of navigation lights for inland waterway vessels (see appendix 2 to the present Rules).<sup>6</sup>

#### **Article 3.17**

Light signals are identified according to their characteristics. The characteristics are given by their colour and the rhythmicity the light source in accordance with annex 8 to Navigation Rules on the Sava River Basin.

### **Obligation not to hinder road and rail traffic**

#### **Article 3.18**

Signs and marking shall be installed in such a way that their lights do not hinder the movements of other modes of transport if the road runs close to the river.

#### **Article 3.19**

In a sector in which a road or a railway runs close to a river, the installation of all the above-mentioned signs and signals shall be carried out in consultation with the respective competent authorities.

---

<sup>4/</sup> The competent authorities may waive these requirements.

<sup>5/</sup> This text is taken from SIGNI

<sup>6</sup> The alternative proposal is to refer to IALA Recommendations E-200 on Marine Signal Lights.

## **Chapter 4**

### **INSTALLATION OF SIGNS AND MARKING IN CHARACTERISTIC SECTIONS OF THE RIVER**

#### **Section 4.1**

#### **General**

##### **Article 4.1.1**

Signs have two possible orientations, namely:

- (a) parallel to the axis of the fairway;
- (b) perpendicular to the axis of the fairway.

##### **Article 4.1.2**

Signs of type (a) are predominantly prohibitory or indicative signs, and are placed on the side of the fairway to which the prohibition or the indication applies.

Bank marks, which are used in relation to navigation in both directions (upstream and downstream), shall be oriented as under (a). In some cases (better visibility) angle between the mark and the axis of the fairway can be 10° or less. (Figure 1, sign a).

##### **Article 4.1.3**

Most signs are positioned as described under (b), and generally do not apply to one side of the fairway only. These signs are erected at right angles to the axis of the fairway so that they are visible to a user when under way.

Bank marks, which are used in relation to navigation in one direction (upstream or downstream), shall be oriented as under (b). In some cases (better visibility) angle between mark and the axis of the fairway cannot be less than 60° (Figure 1, sign c).

##### **Article 4.1.4**

The use of a particular floating sign or bank mark and how it is installed depends, on the one hand on the local features of the river (speed of current, variation in levels, meanders, width of the river bed, existence of sills, branches, islands, etc.) and, on the other hand, on the density of traffic in a given sector and the form and size of convoys.

##### **Article 4.1.5**

The position of each floating sign indicating the side of the fairway shall be determined on the basis of the marking plan based on the results of measurements. Depths within the limits of the width of the marked fairway shall under no circumstances be less than the minimum depth reported for the sector in question.

##### **Article 4.1.6**

When floating signs are installed, it is essential to take the direction of the current into account. If the current flows in the direction of navigational hazard (an obstacle), the sign or signal shall always be placed a long way from it; if, on the other hand, it flows in the opposite direction, the sign or signal shall be placed nearer.

##### **Article 4.1.7**

Obstacles on the sides of the fairway are always marked with floating signs. When the obstacle is indicated by a single sign, it shall be placed on the upstream extremity of the obstacle, on the fairway side (Figure 1, sign b).

**Figure 1**

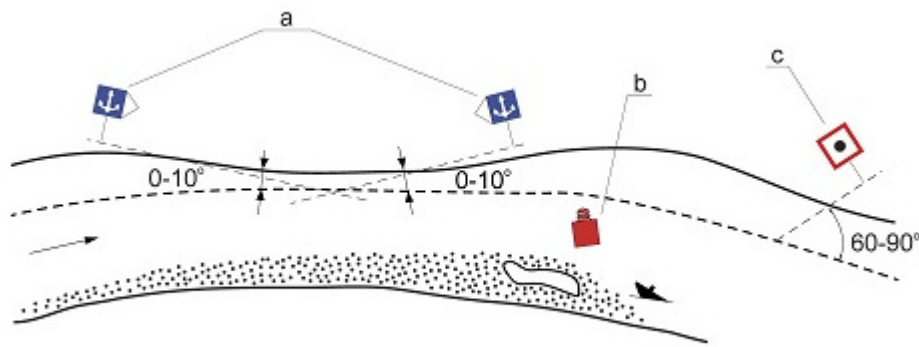

**Article 4.1.8**

As a rule, lighted buoys or unlighted buoys shall be used to mark the upstream and downstream extremities of sills, banks which narrow the fairway in meandering sectors, banks protruding into the fairway, piles of stones, reefs, water supply engineering structures, and underwater hazards or obstacles (sunken vessels, anchors, etc.).

**Article 4.1.9**

Marker posts and spars shall be used as additional signs supplementing buoys in order to give a clearer indication of the limits of the fairway over difficult sills and in order to mark underwater obstacles. In some cases and in some sectors, buoys may be replaced by marker posts or spars.

**Article 4.1.10**

In order to avoid damage to buoys during the period when ice is carried down, they shall be replaced by spars or marker posts.

**Article 4.1.11**

On sectors of the river where there is day and night navigation, forks, junctions and the axis of the fairway, along with obstacles to navigation lying within the fairway, shall be marked by light buoys or bank marks and lights. Floating signs shall be installed at such a depth and at such a distance from the obstacle that the safety and ease of movement of vessels shall be guaranteed at night and in poor visibility.

**Article 4.1.12**

On sectors where the river bed is narrow, preference shall be given to bank marks.

**Article 4.1.13**

Each bank mark shall be established following reconnaissance of the area and selection of the most appropriate site. The need to ensure the visibility of the sign whatever the level of the water should be taken into consideration.

**Article 4.1.14**

Where it is necessary to ensure good visibility of the symbol on the sign over a long distance, both for vessels proceeding upstream and vessels proceeding downstream, two boards may be installed on the sign pole at an angle to each other, one pointing upstream and the other downstream.

**Article 4.1.15**

In selecting the site of a bank mark, account shall be taken of the need to ensure easy maintenance and to protect it against ice and flooding.

#### **Article 4.1.16**

Before a bank sign or signal is installed, the depth in the area in front of it and in the direction it indicates shall always be measured.

#### **Article 4.1.17**

As a general rule, the objective is that only the network of bank marks shall provide an uninterrupted indication of the position of the fairway as a whole, while the floating signs shall help boatmasters to determine the limits of the fairway.

### **Section 4.2**

#### **Marking of meandering sectors**

##### **Subsection 4.2.1**

##### **Installation of cross-over marks and bank lights**

###### **Article 4.2.1.1**

Cross-over marks and bank lights may be used in meandering sectors in order to indicate that the fairway crosses over from one bank to the other (signs featured in 4.C, 4.D, 5.C, 5.D in Annex 8 to the Navigation Rules on the Sava River Basin).

###### **Article 4.2.1.2**

Cross-over marks and bank lights are placed when the fairway is sufficiently broad, its safety is ensured, and when the direction only requires to be indicated approximately.

###### **Article 4.2.1.3**

Bank lights and cross-over marks shall be selected in such a way as to differentiate cross-overs in terms of their length, in other words in terms of the distance between two neighbouring signs. The length of the cross-over is relative, since it depends on the width of the fairway.

###### **Article 4.2.1.4**

Cross-over marks and bank lights have best results on distances up to 3km. On such sections cross-over marks and bank lights (without floating signs) can be placed under conditions where the available width for navigation is more than two times wider than the minimum prescribed width of the fairway for a particular sector. If the available width for navigation is less than minimum prescribed width of the fairway, cross-over marks and bank lights (without floating signs) cannot be placed at distance greater than 1–1.5 km.

###### **Article 4.2.1.5**

If distance between two neighbouring cross-over marks is larger than calculated visibility, and when the fairway passes close to the bank, the bank mark with light, which additionally marks the position of the fairway, is placed between those two neighbouring cross-over marks (Figure 2, sign a). The bank mark with light is also placed when the fairway passes near the bank (Figure 2, sign b).

**Figure 2**

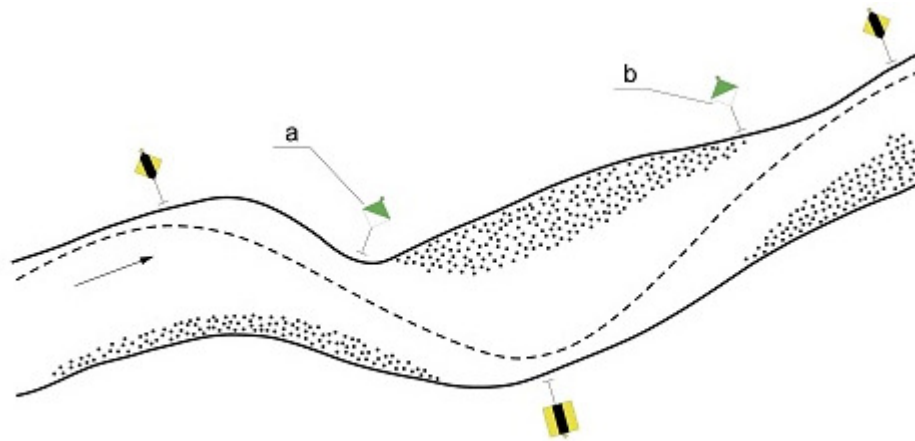

**Article 4.2.1.6**

In case when the direction of the current makes the angle with the fairway, when strong side winds or similar situation occurs, the fairway can be marked by additional navigation marks according to the local conditions (Figure 3).

**Figure 3**

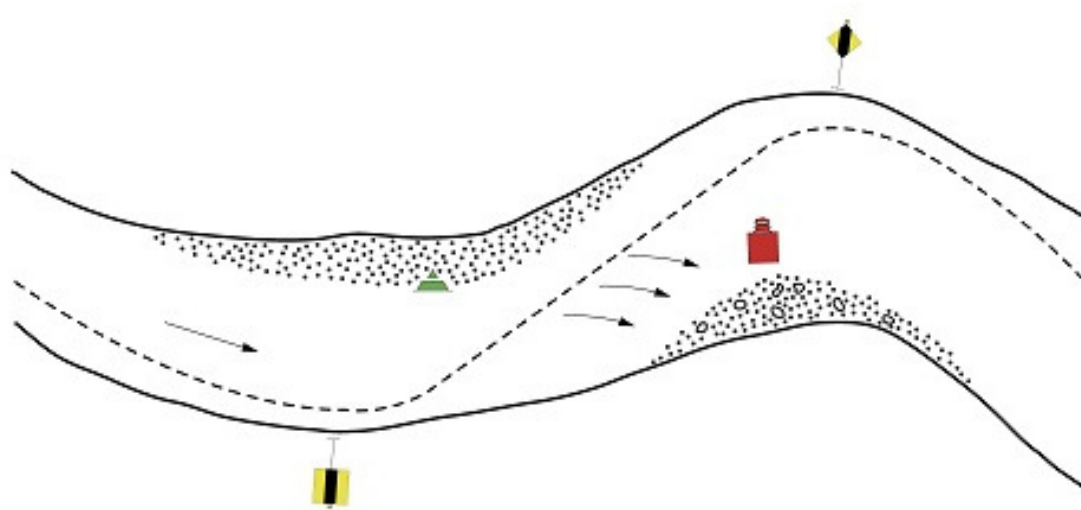

**Article 4.2.1.7**

When the fairway follows the middle of the river bed over a long distance or it crosses abruptly from one bank to the other, its axis may be indicated by a pair of cross-over marks on each side of the fairway, as shown in Figure 4.

The advantage is given to cross-over marks on each side of the fairway in case of straight-line sections longer than 5 km, where the available width for navigation is less than double the width of the minimum prescribed width of the fairway for a particular sector. In that case and when the bank configuration allows so, the cross-over marks are placed on both margins of transition (Figure 4).

It is always preferable to have two cross-over marks on each side of the fairway when the fairway is narrowed by certain obstacles constituting threats to navigation or other hazards marked by floating signs.

**Figure 4**

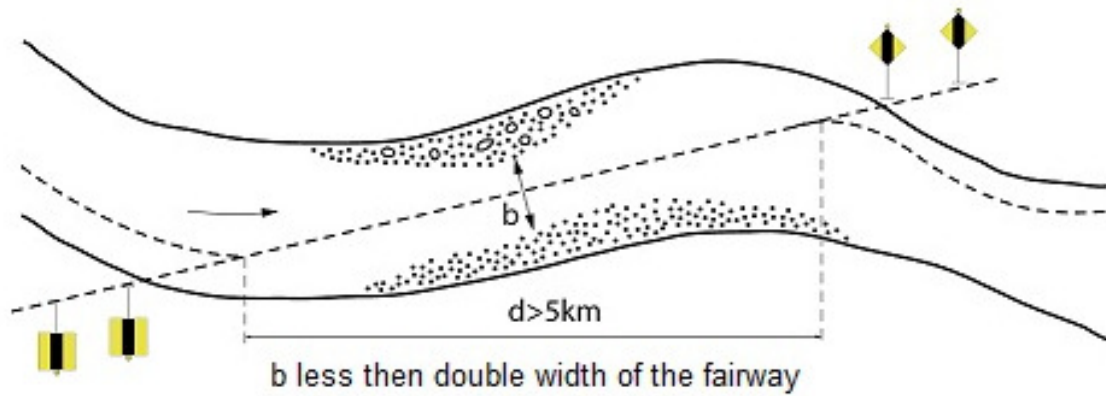

**Article 4.2.1.8**

In sectors where the fairway, after moving to the opposite bank abruptly crosses to the other bank, three cross-over marks (the front shall have two boards) must be placed (Figure 5). In that case, lights of the back cross-over marks shall be oriented strictly on the axis of the fairway: one upstream and other downstream.

**Figure 5**

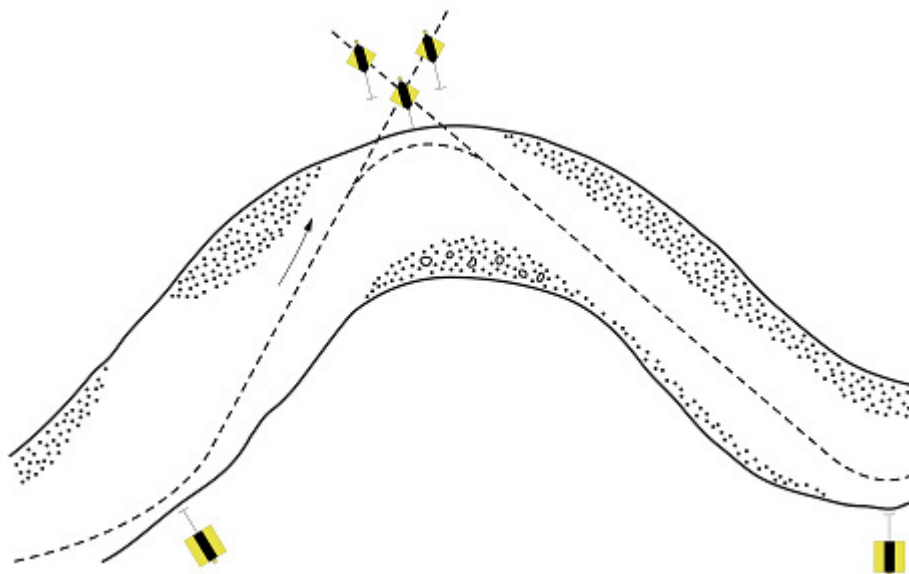

**Article 4.2.1.9**

Interrelation of the front and back marks at hidden routes shorter than 4 km is presented in Table 3.

**Table 3:**

L(m)	d(m)	h <sub>o</sub> (m)	a(m)	2a(m)
200	17	8.50	2.6	5.0
300	25	8.70	4.0	8.0
400	33	8.85	5.2	10.5
500	42	9.00	6.5	13.0
600	50	9.10	8.0	16.0
700	58	9.20	9.0	18.0
800	67	9.35	10.0	20.0
900	75	9.50	12.0	24.0
1000	83	9.60	13.0	26.0
1500	125	10.25	19.0	38.0
2000	166	10.90	26.0	52.0
2500	207	11.50	33.0	66.0
3000	250	12.15	39.0	78.0
3500	290	12.75	46.0	92.0
4000	330	13.40	52.0	104.0
> 4000	760	14.20	25.0	50.0

L (m) – maximal distance when cross-over marks can be used;

d (m) – distance between front and back signs (is approximately  $\frac{1}{12}L$ );

h<sub>o</sub> (m) – height between lights of front and back mark;

a (m) – distance necessary for vessel to adjust the course if doesn't go along the cross-over;

α (°) – viewing angle.

Table 3 also assumes that the observer's sight is 5m above the water level, and light of the lower (front) sign is 8m above the water level.

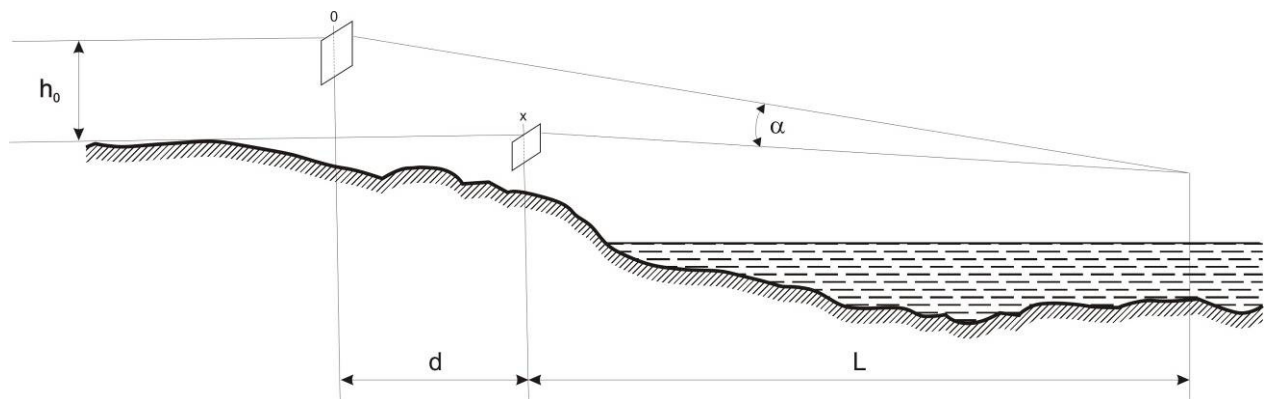

Value "a" describes accuracy of the route and it's of significance while navigating through a narrow fairway. Accuracy is, in principle, increased by approaching the cross-over marks.

To ensure proper recognition of cross-over marks and their lights by night, the viewing angle α cannot be less than 4 angular minutes in relation to the vertical.



**Subsection 4.2.2**  
**Installation of floating signs**

**Article 4.2.2.1**

In meandering sectors, where the fairway passes along the middle of the river bed, or along the bank or passes slowly from one bank to the other, floating signs are used to mark formations in the river bed or obstacles, both natural and artificial, on the sides of the fairway (banks, shores, islands, stones, sunken vessels, wrecks of bridges, etc.), when these obstacles protrude into the fairway and reduce its width (Figure 6).

These underwater obstacles are marked in meandering sectors by floating signs if, within the limits of width indicated above, the depth of water over such obstacles does not exceed the minimum depth reported for the sector. If the obstacle is not very wide floating sign with light shall be installed on its upstream section. A marker post or a spar may be installed on its downstream section, depending on its length.

**Figure 6**

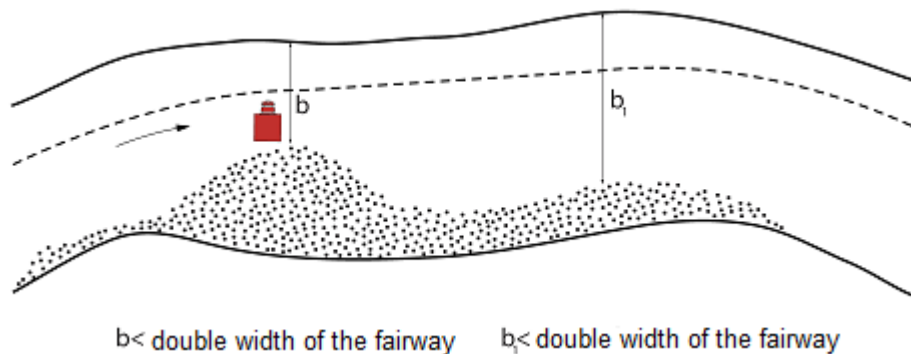

**Article 4.2.2.2**

Floating signs marking the underwater obstacles of considerable length are installed in such a way that the parts situated closest to the fairway are marked by light signals between which unlighted signs are placed, thus enabling a given obstacle to be marked completely (Figure 7).

**Figure 7**

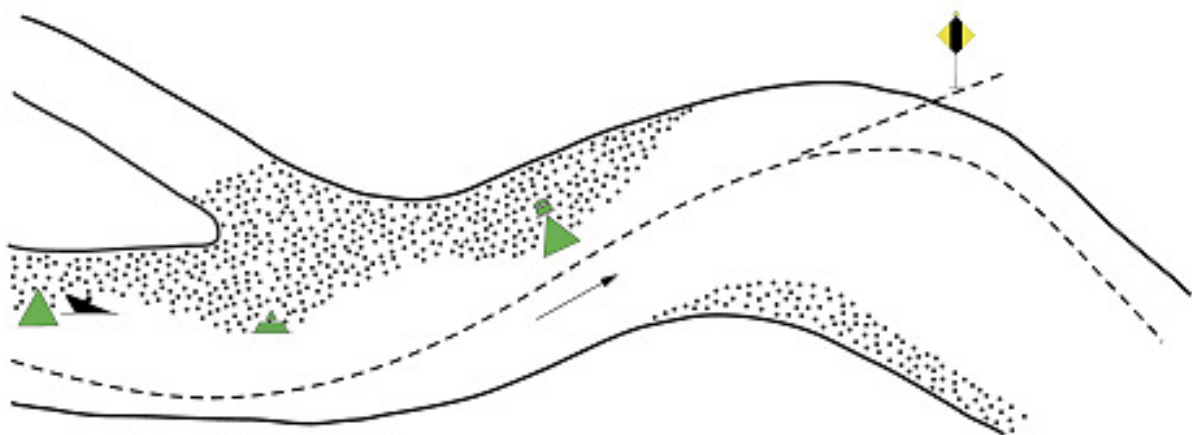

**Article 4.2.2.3**

In the parts of the river bed where the shore opposite that followed by the fairway is bordered by an inshore bank, which favours upstream navigation in calm water, the bank is marked by floating signs independently of the width of the river bed.

#### Article 4.2.2.4

In meandering sectors, the bank marking system in periods of high water generally remains the same as in periods of lowest water level, except in sectors where, when water levels are high, it is advisable to find another fairway with better navigational features. In this case, the selected fairway shall be marked appropriately.

### Section 4.3 Marking of shoals

#### Article 4.3.1

In shoals, as in other sections, the principle of the continuous marking of the direction of the fairway, shall be applied.

In shoals the fairway can be marked by cross-over marks, bank marks and floating signs.

#### Article 4.3.2

Alternately located shoals may also be marked by cross-over marks, with sufficient available width for navigation in which vessels are passing in straight-line (Figure 8).

**Figure 8**

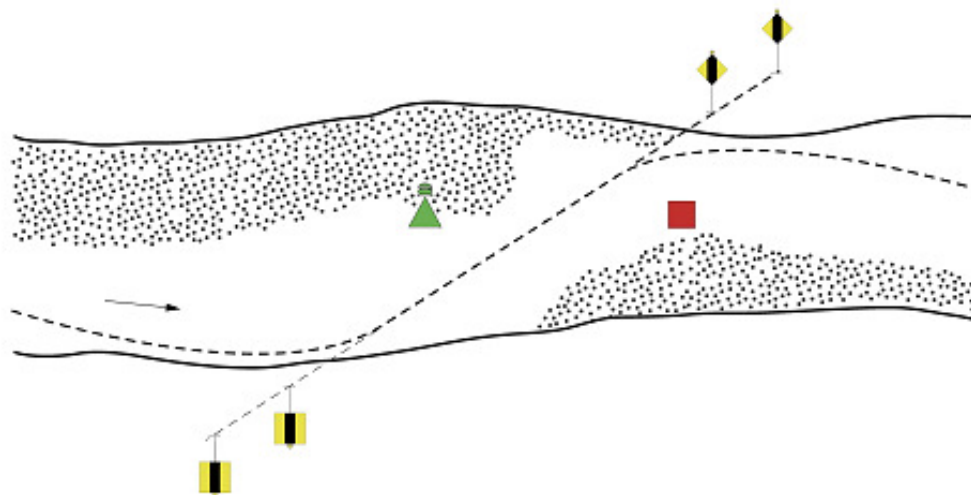

#### Article 4.3.3

A fairway passing over shoals is usually marked by floating signs (Figures 8 and 9).

**Figure 9**

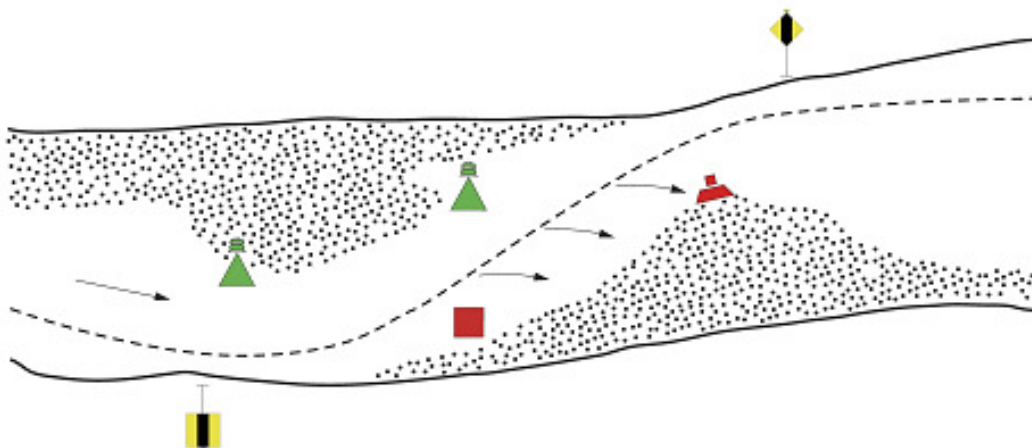

#### Article 4.3.4

If the fairway passes in a straight line between sandbars, reaching far into the riverbed, it is necessary to place at least two floating signs at the entry and exit of such a section: one at the top of the upstream and other one on the top of the downstream sandbar (Figure 10).

**Figure 10**

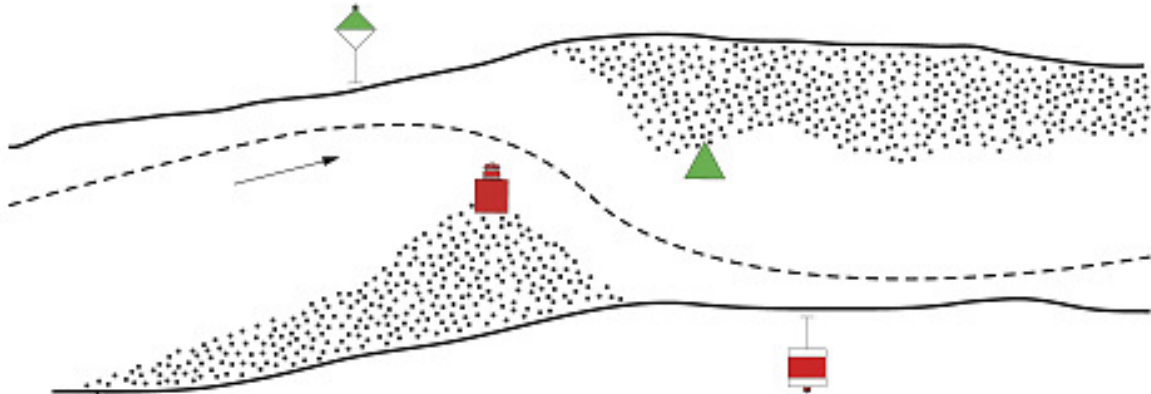

#### Article 4.3.5

If the fairway is curved in the section between sandbars, it's necessary to place additional floating signs (Figure 11).

**Figure 11**

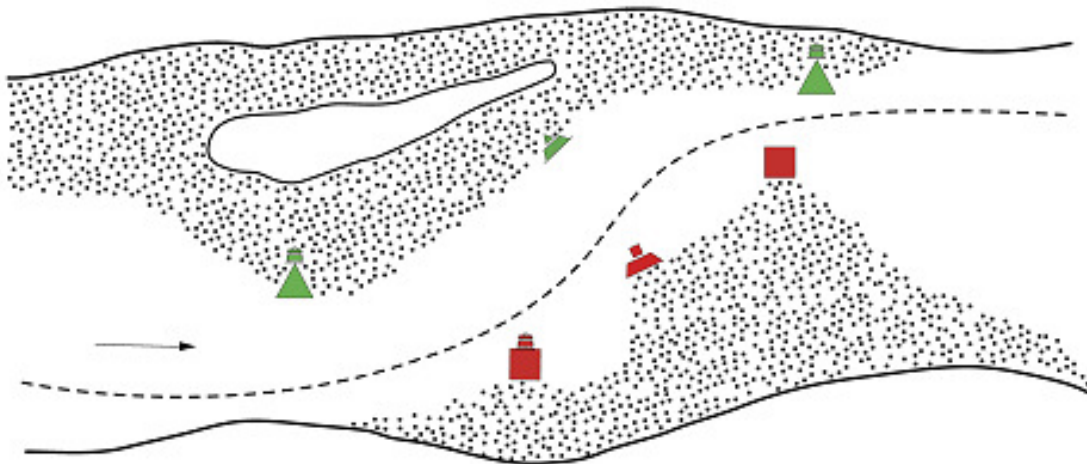

#### Article 4.3.6

Additional floating signs shall also be placed on the entry and exit of rugged sections with sandbars, which also characterize the side streams.

#### Article 4.3.7

In case the application of cross-over marks is impossible, the fairway across a shoal may be marked by floating signs, on one or both sides, depending on the width of the fairway and hydrological conditions.

## **Section 4.4**

### **Marking of the vicinity of bridges and passages through bridges**

#### **Article 4.4.1**

The navigation of vessels and towed or pushed convoys in the vicinity of bridges and through bridge passages requires particular attention and precautions on the part of boatmasters because of the narrow fairway. These sections must therefore, be marked with the greatest care.

#### **Article 4.4.2**

The basic condition to be met to ensure safe passage through bridges is the marking of the direction of the fairway and also, where necessary, its sides,. Floating signs and bank marks may be used in addition to boards and lights for marking the navigable passage through bridges.

#### **Article 4.4.3**

The choice and positioning of the marking signs depends in each case on local conditions in the bridge section.

#### **Article 4.4.4**

The installation of marking signs in the vicinity of bridges and the buoying of navigable passages shall comply with the following conditions:

- (a) In order to indicate permission to use the navigable passage of a bridge, only signs A.10, D.1 or D.2 in Annex 7 to the Navigation Rules on the Sava River Basin shall be used;
- (b) The installation of marking signs shall be based on depth and current direction measurements, both in the immediate vicinity of the bridge and in the approach sections;
- (c) The positioning of the signs installed in the vicinity of a bridge shall be modified in due course, as conditions of navigation change;
- (d) If, when approaching the bridge or the navigable passage, the direction of the current forms an angle with the bridge, giving rise to eddies around the pillars of the bridge, the signs on the water shall be installed so as to indicate the direction of the eddies.

#### **Article 4.4.5**

Floating signs may be installed at the approach to the navigable passage to give an exact indication of the position of the fairway.

#### **Article 4.4.6**

The following examples show the placement of the aforementioned signs marking the section near the bridges:

- (a) If a bridge is in a meandering section of the river, the direction of vessels passing through the bridge passages may be marked by bank marks (Figure 12).

**Figure 12**

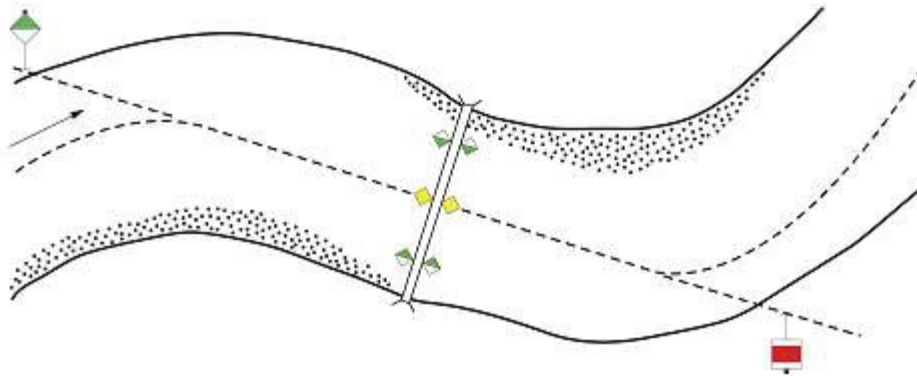

- (b) If, due to larger curvature of the fairway or some other reasons, marking by the aforementioned signs is not possible, floating signs (buoys, etc.), placed in order to follow the current, may be used (Figure 13).

**Figure 13**

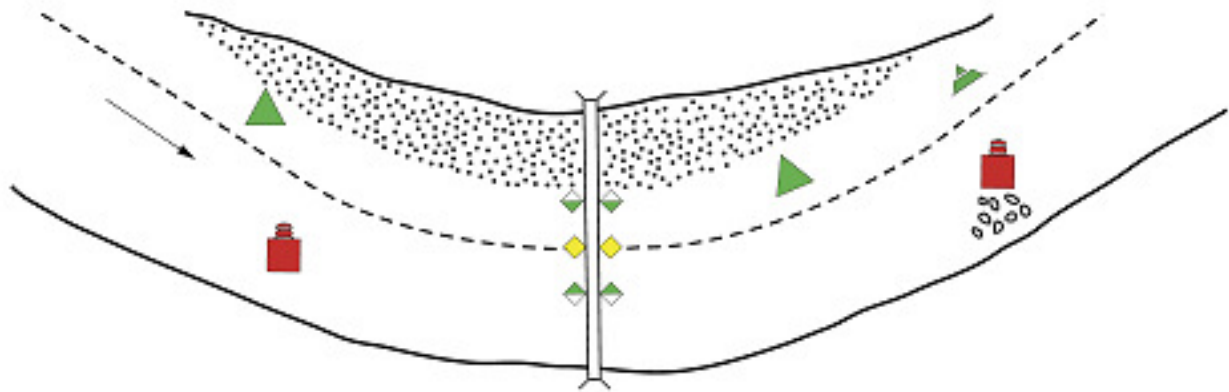

- (c) If the bridge is positioned on section where the current makes an angle with the axis of the navigable passage, marking may be done by two pairs of buoys upstream of the bridge. One pair of buoys is placed at distance of 100m - 200m upstream of the bridge, and second pair, 400m - 700m upstream of bridge. Buoys further away from the bridge are placed in such a way that in combination with the pair of buoys closer to the bridge, they mark the river flow. Another pair of buoys may be placed downstream of bridge at a distance 100m from the bridge (Figure 14).

**Figure 14**

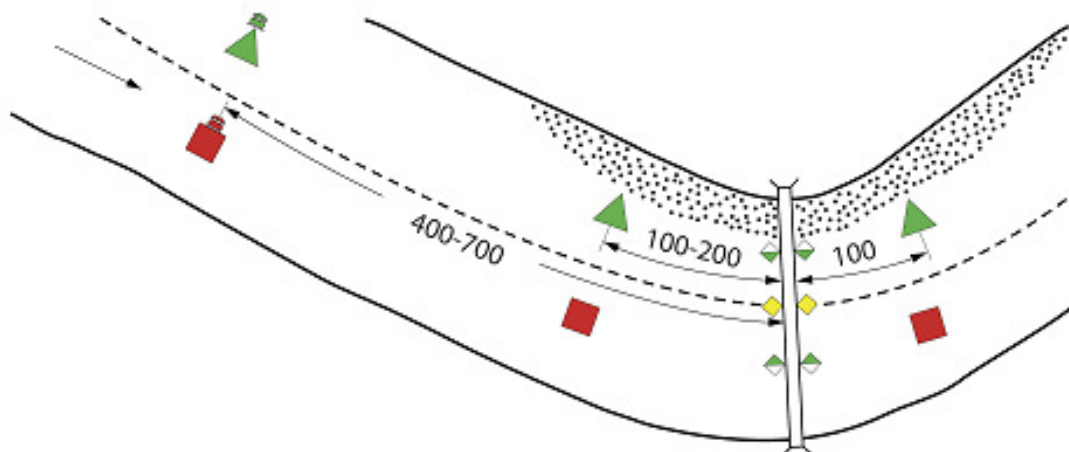

**Section 4.5**  
**Marking of the winter harbours and winter shelters**

**Article 4.5.1**

Examples of winter harbour and winter shelter marking:

- (a) Marking of the winter shelter in the open waterway - with marks E.27.1 defining maximum number of vessels allowed in the winter shelter, along with the additional panels showing the distance at which the regulation applies (Figure 15).

**Figure 15**

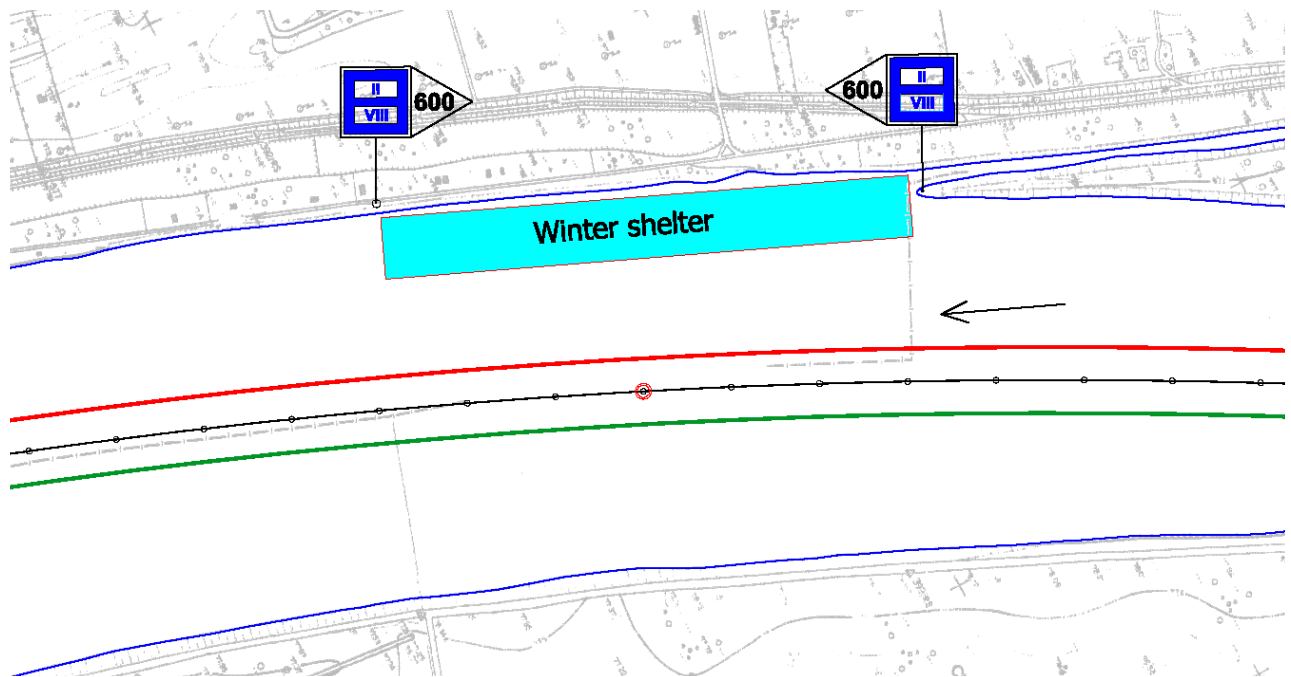

- (b) Marking of the winter harbour in the river branch - with mark E.26.1 defining maximum number of vessels allowed in the winter harbour and additional mark E.25 for available electric power supply (Figure 16).

**Figure 16**

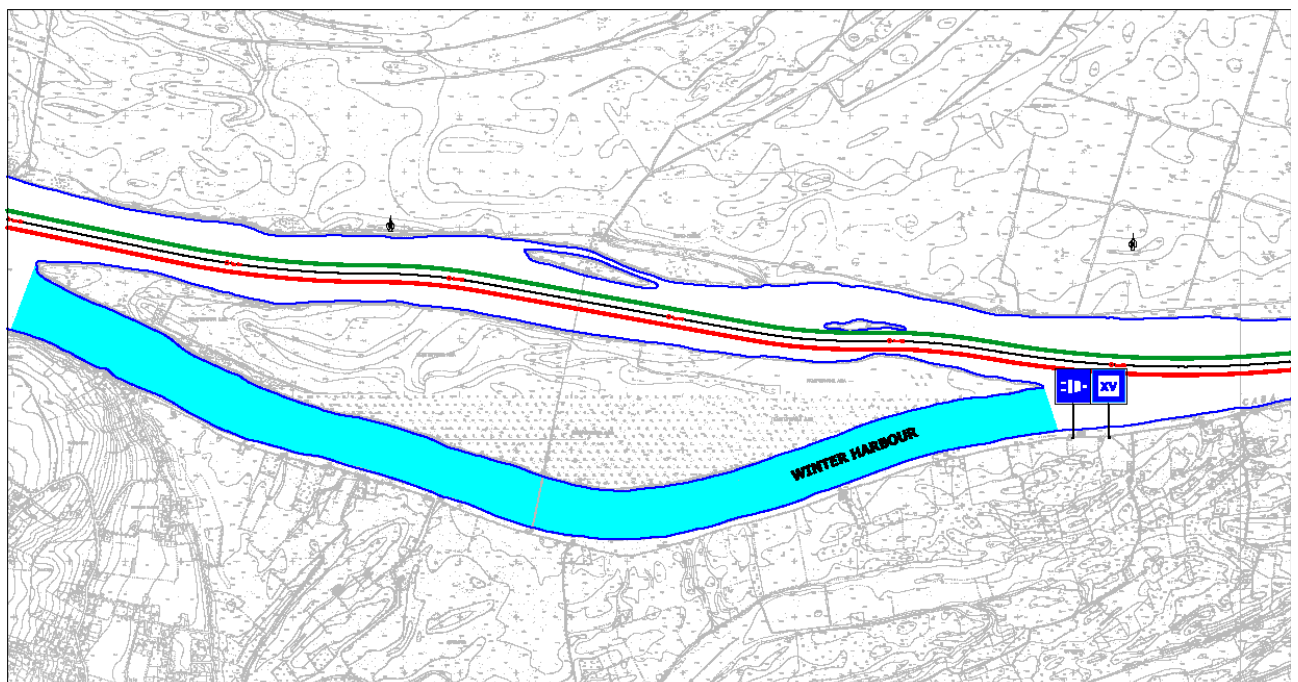



## **Section 4.6**

### **Installation of floating signs and restricting the berthing points**

#### **Article 4.6.1**

Where there is increased intensity of vessels' traffic and the substantial accumulation of vessels in inner harbour basins of ports, not only banks marks should be used in order to restrict the berthing places, but also floating signs.

## **Section 4.7**

### **Reference numbers on buoys and markers**

#### **Article 4.7.1**

On buoys and markers the use of alphanumeric characters and capital letters is recommended. Where both letters and figures are used, their heights should be the same. Where two such combinations occur, as on junction markers, a hyphen should be used.

#### **Article 4.7.2**

Characters should not be less than 200 mm high, white on red or green buoys, or black on yellow buoys.

#### **Article 4.7.3**

The characters on a lighted buoy can be black on a white background. Signs are usually affixed to special nameplates. It is recommended that the characters are displayed on both sides of buoys.

## **Chapter 5**

### **VARIABLE MESSAGE SIGNS TO REGULATE TRAFFIC**

#### **Article 5.1**

When variable message signs are used to regulate traffic, attention must be paid to the following:

- (a) If variable message signs regulating traffic show images of signs from Annex 7 to NAVIGATION RULES ON THE SAVA RIVER BASIN, the images must be depicted using a mechanical display system. Annexes 1 and 3 are applicable with regard to colour selection and dimensions;
- (b) By night, mechanical display systems shall be externally lit. Annex 4 shall be applicable;
- (c) The use of auto-illumination display systems should be avoided for the signs in Annex 7 to NAVIGATION RULES ON THE SAVA RIVER BASIN. Inverse representation (e.g. inversion of black and white surfaces for prohibitory signs) shall not be allowed;
- (d) A remote controlled auto-illumination matrix display may constitute a reasonable alternative in order to indicate frequently changing information, such as water levels and the height of navigable passages through bridges. Technically, it is possible to display images using light emitting diodes, liquid crystals and light guides;
- (e) By day, there must be sufficient luminosity to ensure the sign can be read; by night, luminosity must be reduced in order to prevent any dazzling and to ensure that the sign can be identified. The image must thus be regulated according to light measurements in the surroundings.

#### **Article 5.2**

Examples of variable message signs to regulate traffic are contained in Annex 5.

## Chapter 6

### INSTALLATION OF RADAR REFLECTORS ON MARKING SIGNS AND SIGNALS AND NAVIGABLE PASSES THROUGH BRIDGES

#### Article 6.1

It is important to equip floating signs and bank marks with radar reflectors to ensure their visibility.

#### Article 6.2

When marking signs equipped with radar reflectors are installed, account must be taken of the furthest distance between the vessel and the sign in terms of the perception of the sign on the radar screen. This distance depends on the technical characteristics of the radar equipment, the reflective capacity of the radar reflectors and the specific conditions of the river and the height of the antenna installed on the vessel, as well as the height of the radar reflector, both in relation to the water surface.

#### Article 6.3

Since the visibility of bridge pillars is usually insufficient on radar screens, the bridge pillars for the passage of vessels upstream and downstream must be marked either by buoys equipped with radar reflectors placed not less than 15–20 m before the bridge, or by radar reflectors installed on the bridge itself not less than 12–15m from the farthest edge of bridge construction (Figure 15). A sketch of the recommended radar reflector is contained in section 3.4 of the Annex 1.

**Figure 15**

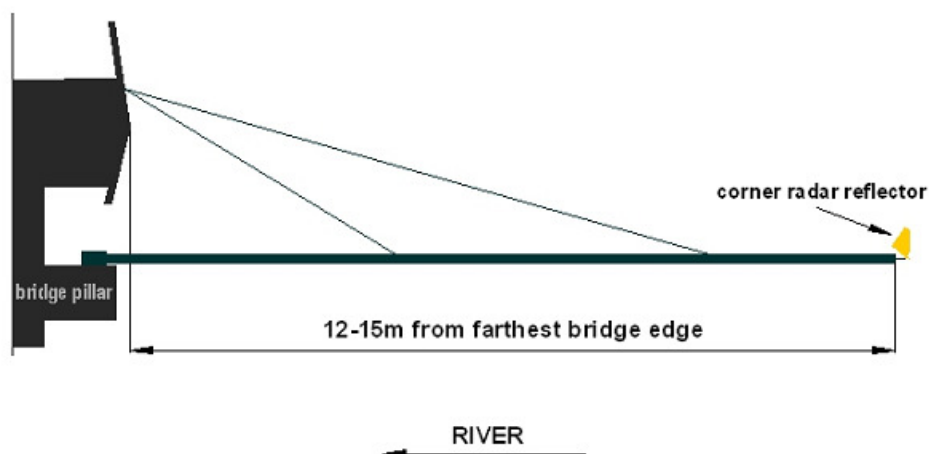

#### Article 6.4

Since the radar reflector improves navigation safety, every effort should be made to install them by means of supports on the framework of bridges to mark the navigable passage through the bridge.

#### Article 6.5

Navigational hazards and water supply engineering structures (sunken vessels, groynes, cross-beams, etc.) located in the river bed may also be marked by signs equipped with radar reflectors. If the groynes or cross-beams marked by radar reflector signals are located along one of the banks while the fairway follows the opposite bank, which is low and flat, the radar reflector signals may also be placed on that bank so as to facilitate the orientation of vessels navigating by radar.

#### Article 6.6

When radar reflectors are used on marking signs and signals, the visibility of the sign must not be diminished. Their colour shall also correspond to the colour of the sign in question.



#### **Article 6.7**

Radar reflectors on fairway buoys are most often manufactured using two vertical metal plates set as a cross, with a horizontal metal plate intersecting them at a right angle. The reflectors should be made of aluminium or stainless steel.

#### **Article 6.8**

Practical experience has shown that there is a need for, at least, two standard sizes of reflectors on buoys and markers. Recommended dimensions are as follows:

type 1: tip to tip height 420 mm

type 2: tip to tip height 850 mm

#### **Article 6.9**

The square plate referred to in article 6.7 has a diagonal of 300 or 600 mm respectively and sides of 210 or 425 mm respectively.

# ANNEX 1 MINIMAL DIMENSIONS OF THE SIGNS FROM ANNEX 7 AND 8 OF THE CEVNI

## 1. Visibility of navigation signs

Guidance on the maximum distances at which the various signs are visible is given in the figure 1<sup>7</sup>. The distances are valid for boards with dimensions of 100 cm x 100 cm and 150 cm x 100 cm, with the observer positioned at a right angle to the surface of the board. When using boards of other dimensions, the distance at which the sign is visible should be recalculated according to the chosen scale.

Sign images:

**Figure 1**

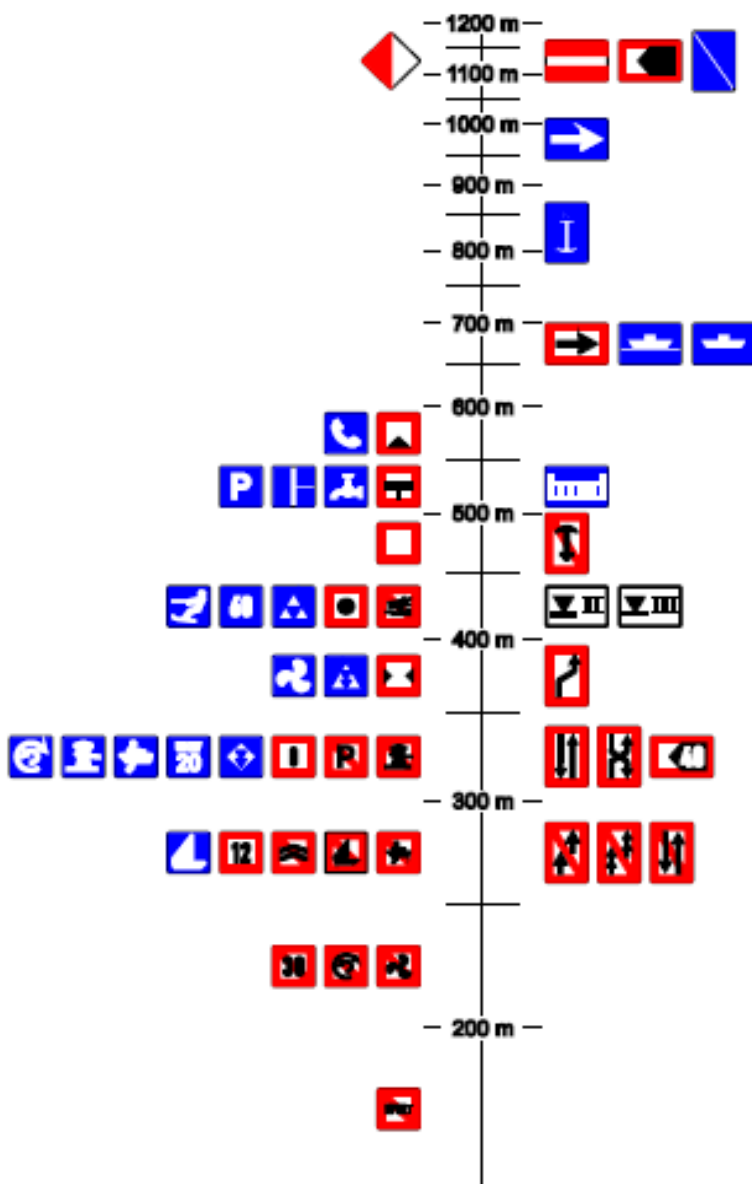

Characters:

<sup>7</sup> This publication is referred to in the IALA Guideline No. 1094 On Daymarks for Aids to Navigation, Edition 1, December 2012.

For many types of European characters, when using black type on a white background, the maximum readability distance  $D$  — if the observer is positioned at a right angle to the surface of the board — is approximately  $D \approx 465 \times h$ , where  $h$  equals the height of the character (height of capital letters above the line).

Viewed at an angle:

If seen askew, the maximum visibility or readability distance of the board is reduced each time by the cosine of angles  $h$  and  $v$  between the observer and the central perpendicular line:

$$D(h, v) = D_o \cos(h) \cos(v).$$

**Fig. 2**

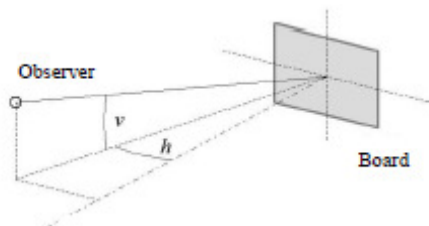

Central perpendicular line

When the observer is at a great distance, the vertical angle shall be considered to be approximately 0:  $v \approx 0$ . In such cases, the following formula can be used as guidance to determine the visibility distance:  $D(h, v) \approx D(h) = D_o \cos(h)$ . The area of visibility is thus a circle with a diameter of  $D_o$ .

**Fig. 3**

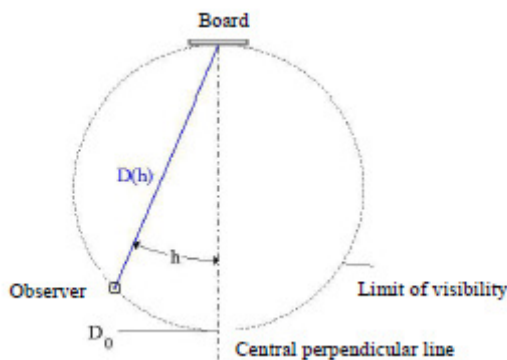

Note: Etude de la perceptibilité des symboles et des inscriptions sur les signaux de navigation (Study of symbol and inscription visibility on navigation signs), Gerdes, paper presented at the 1990 International Conference on Maritime Signs.

**Table 1**  
**2. Minimal dimensions of the signs contained in annex 7 to the European Code for Inland Waterways**

**Section I: Main signs**

**A. Prohibitory signs**

**A.1**

(No entry)

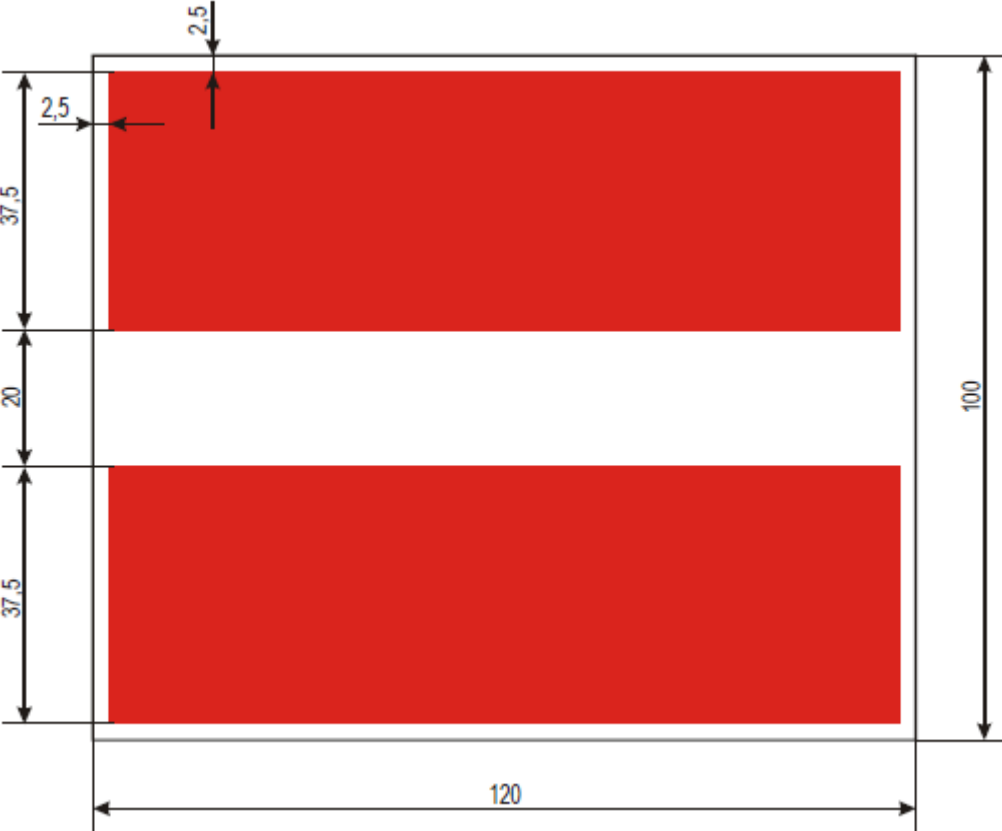

A.1.1

(Sections closed to use, no entry except for non-motorized small craft)

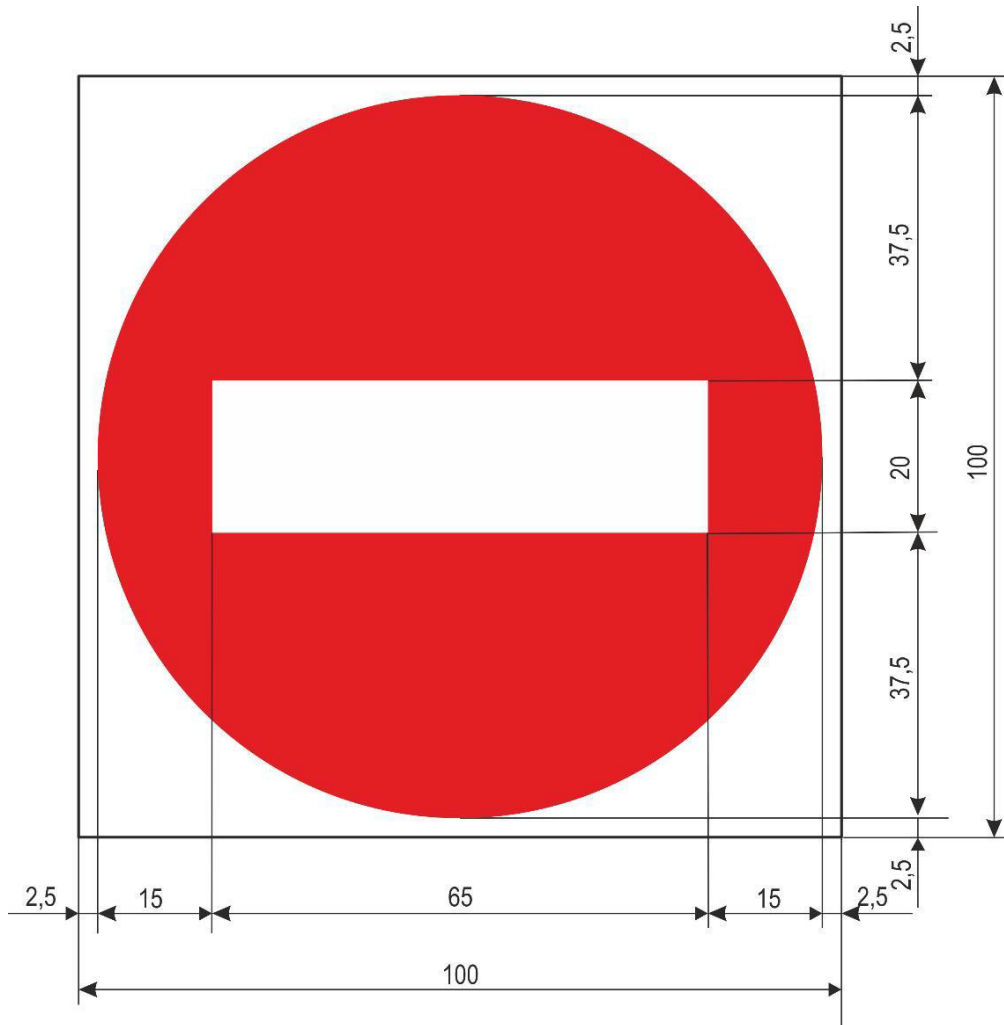

A.2  
(No overtaking)

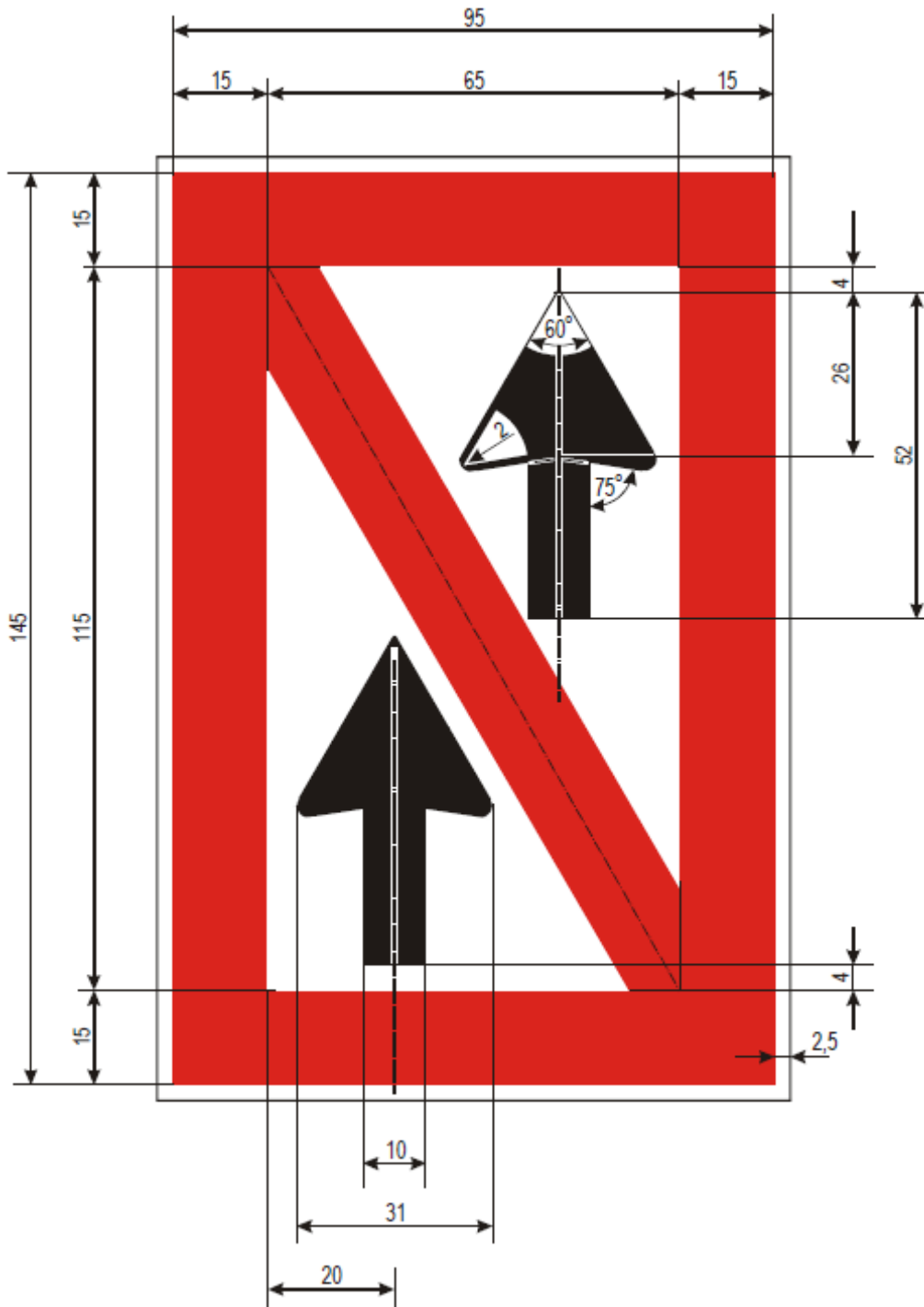

### A.3

(No overtaking of convoys by convoys)

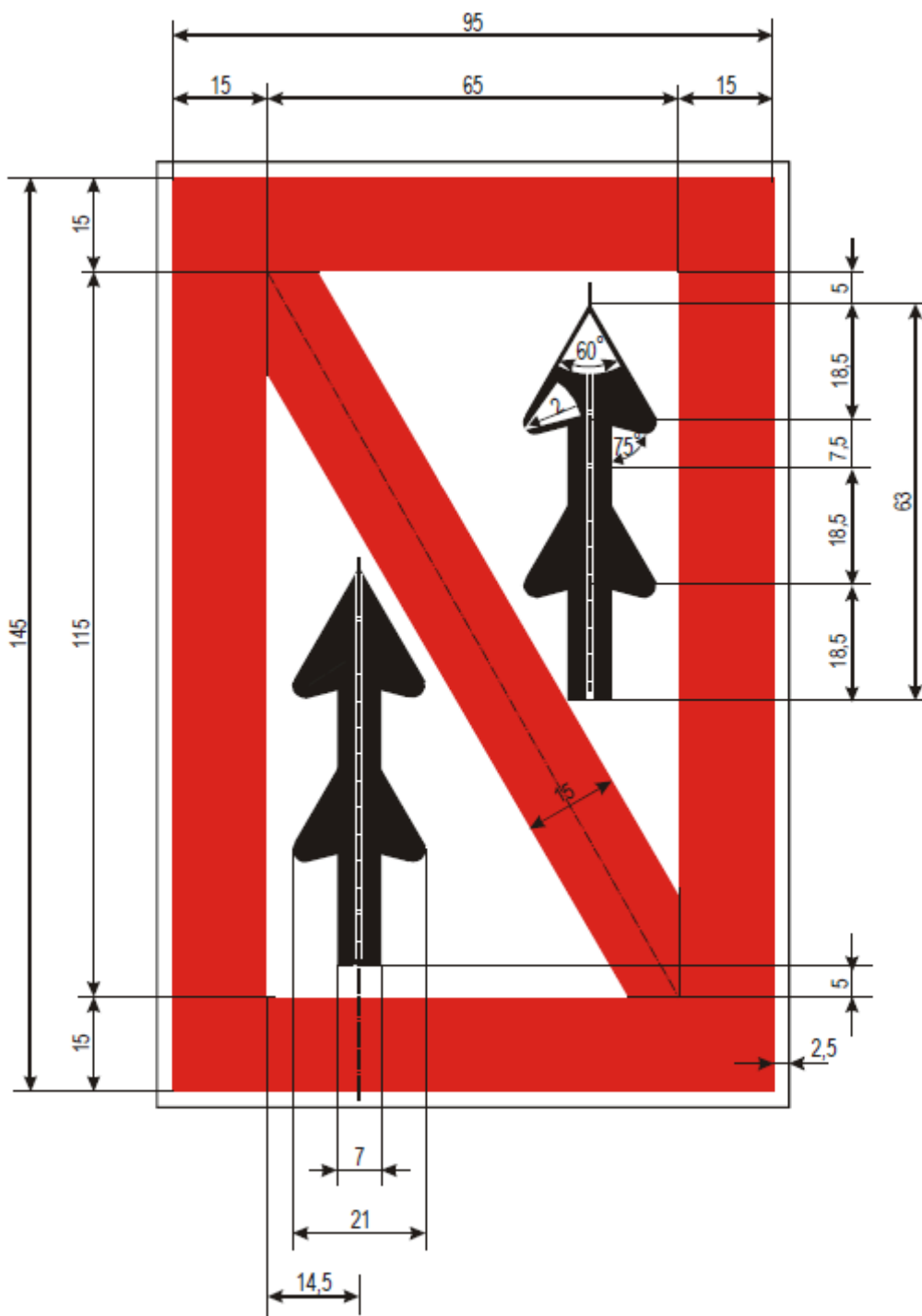

#### A.4

(No passing or overtaking)

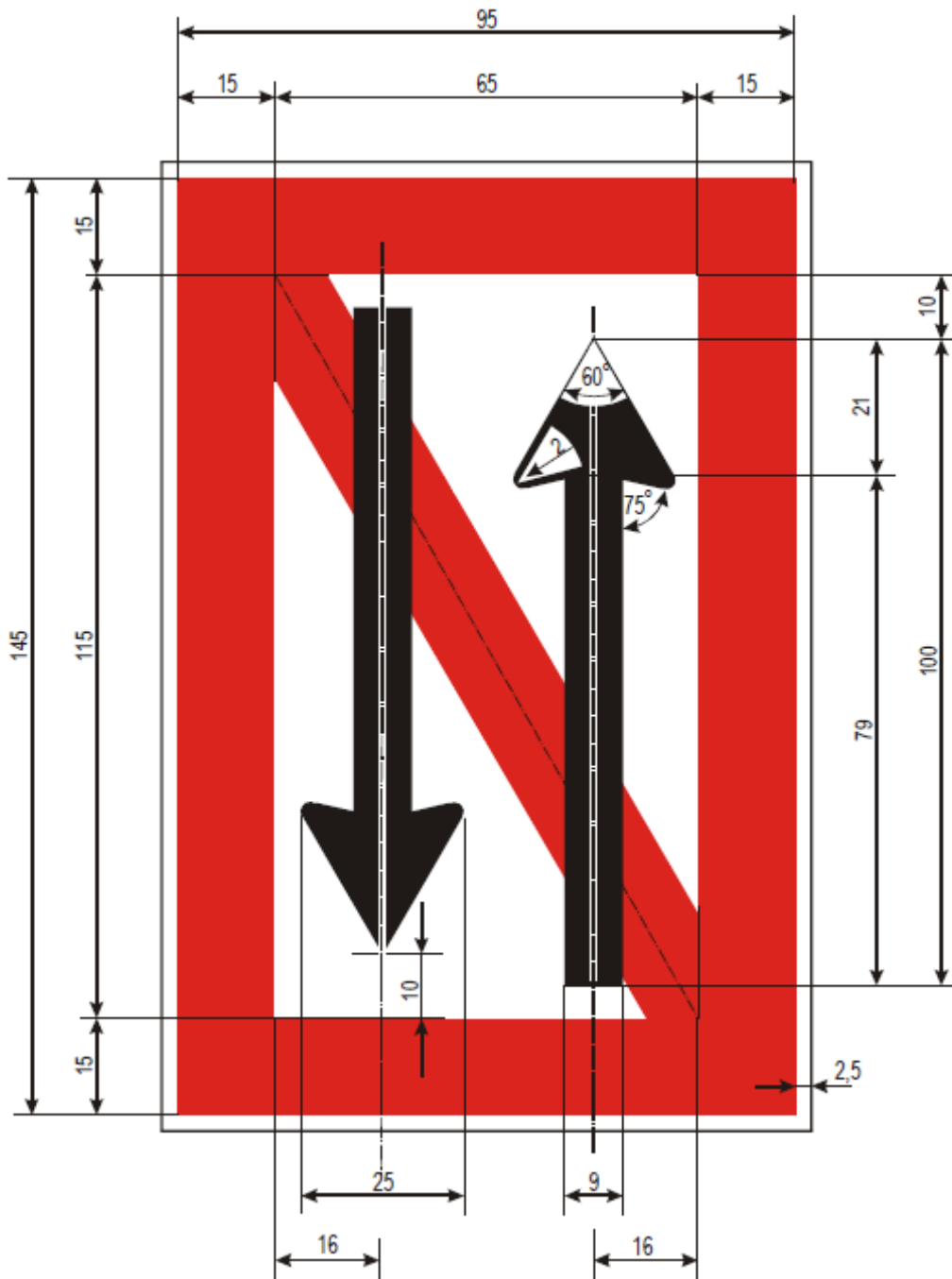



### A.4.1

(No passing or overtaking of convoys by convoys)

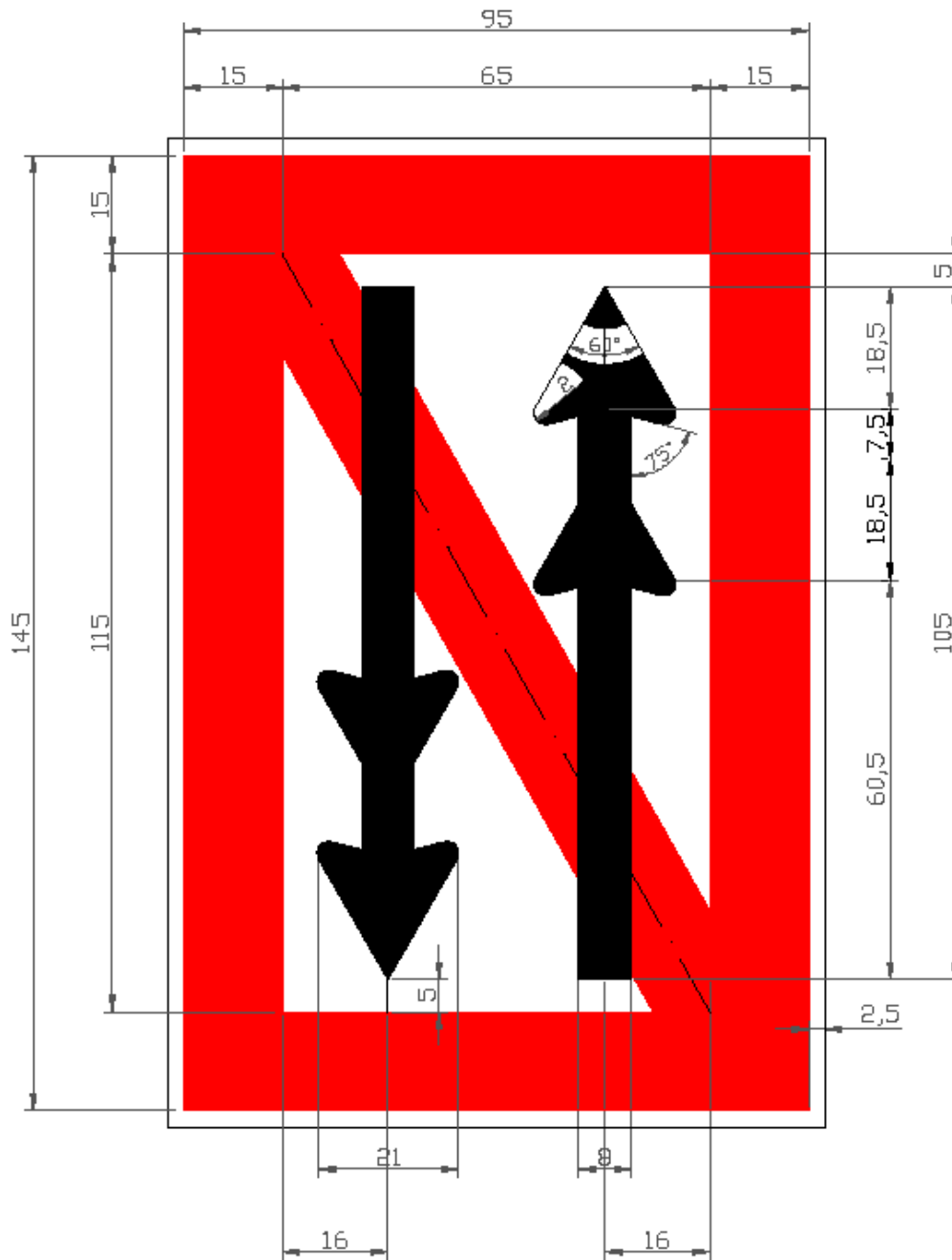

### A.5

(No berthing (i.e. no anchoring or making fast to the bank))

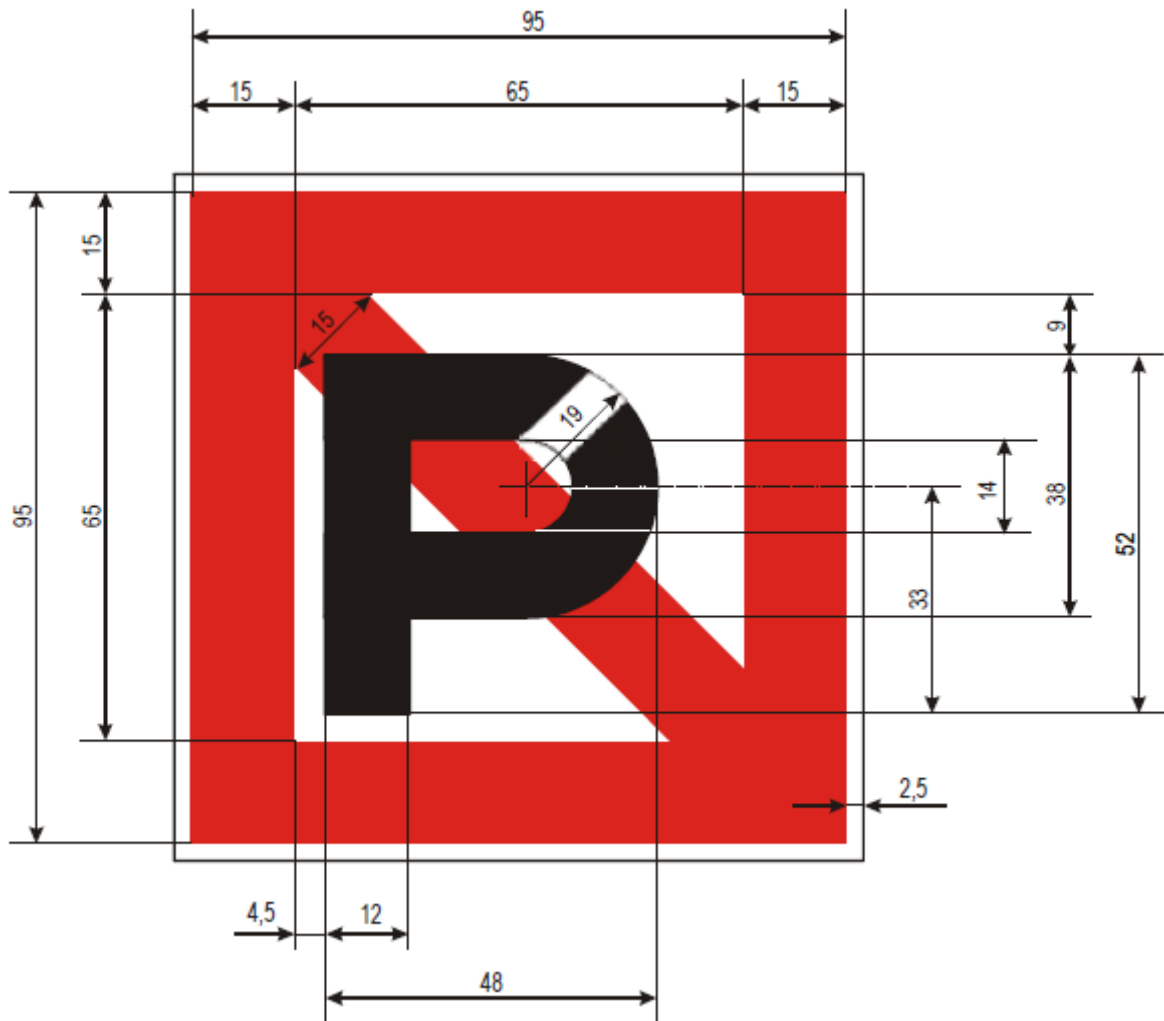

### A.5.1

(No berthing within the breadth indicated in meters)

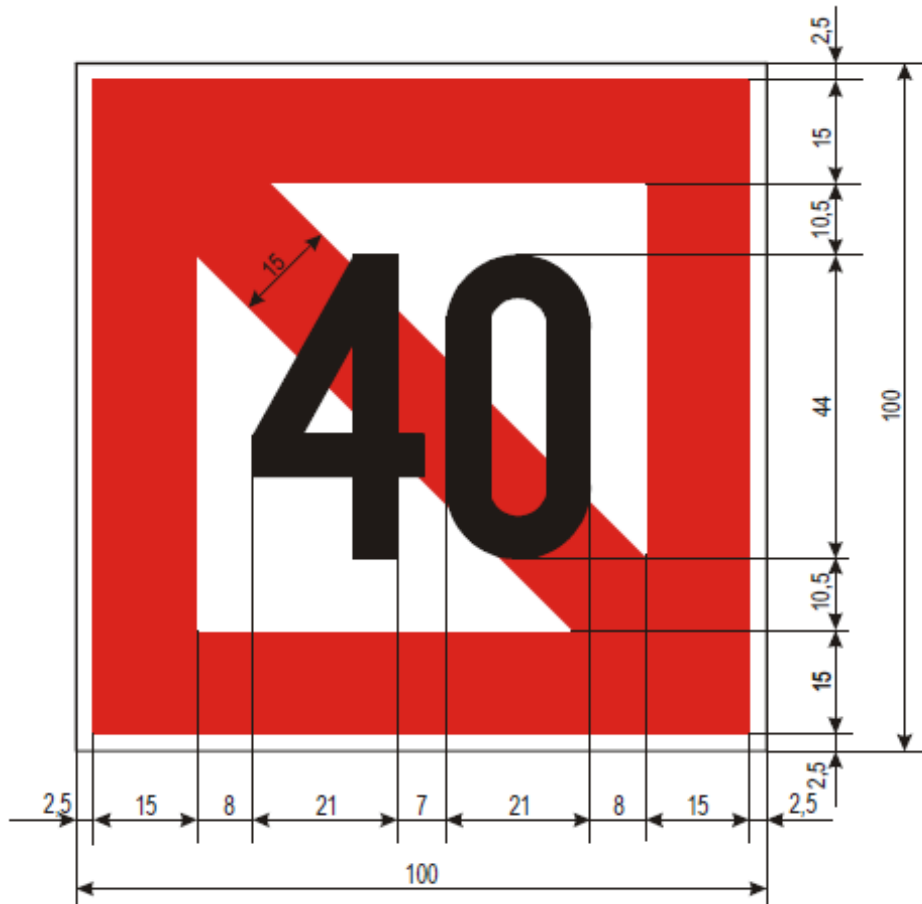

### A.6

(No anchoring or trailing of anchors, cables or chains)

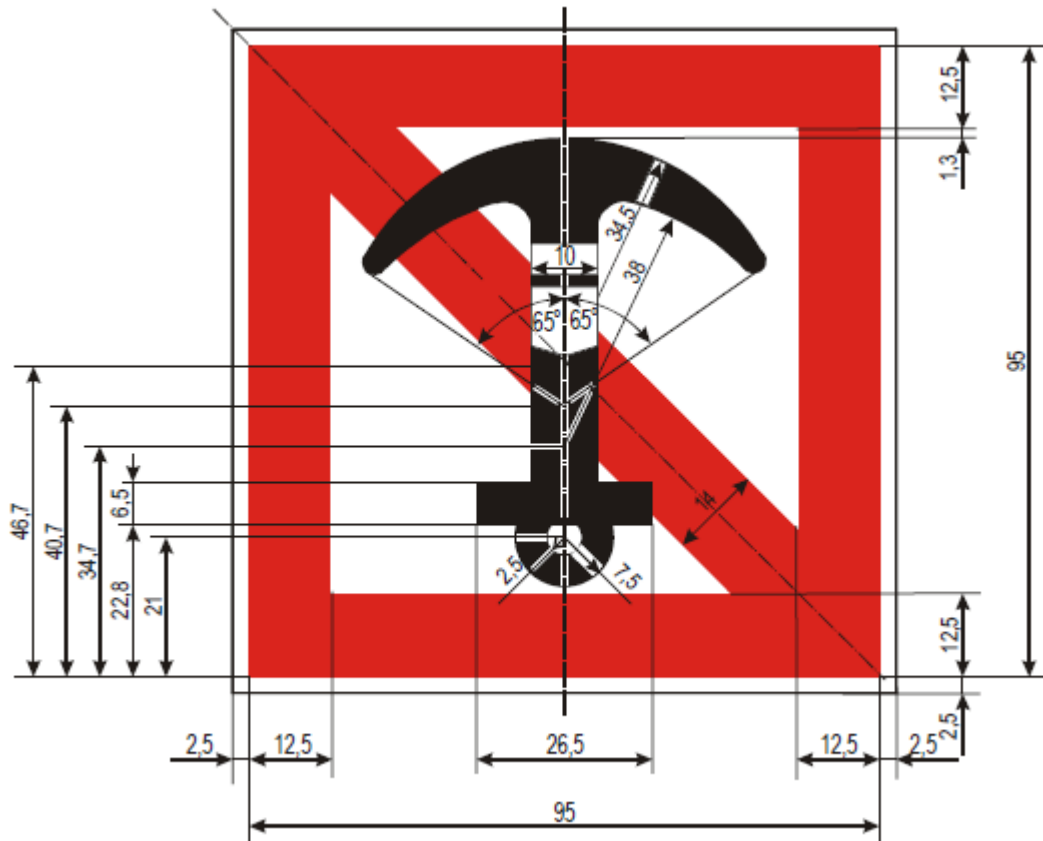

### A.7

(No making fast to the bank)

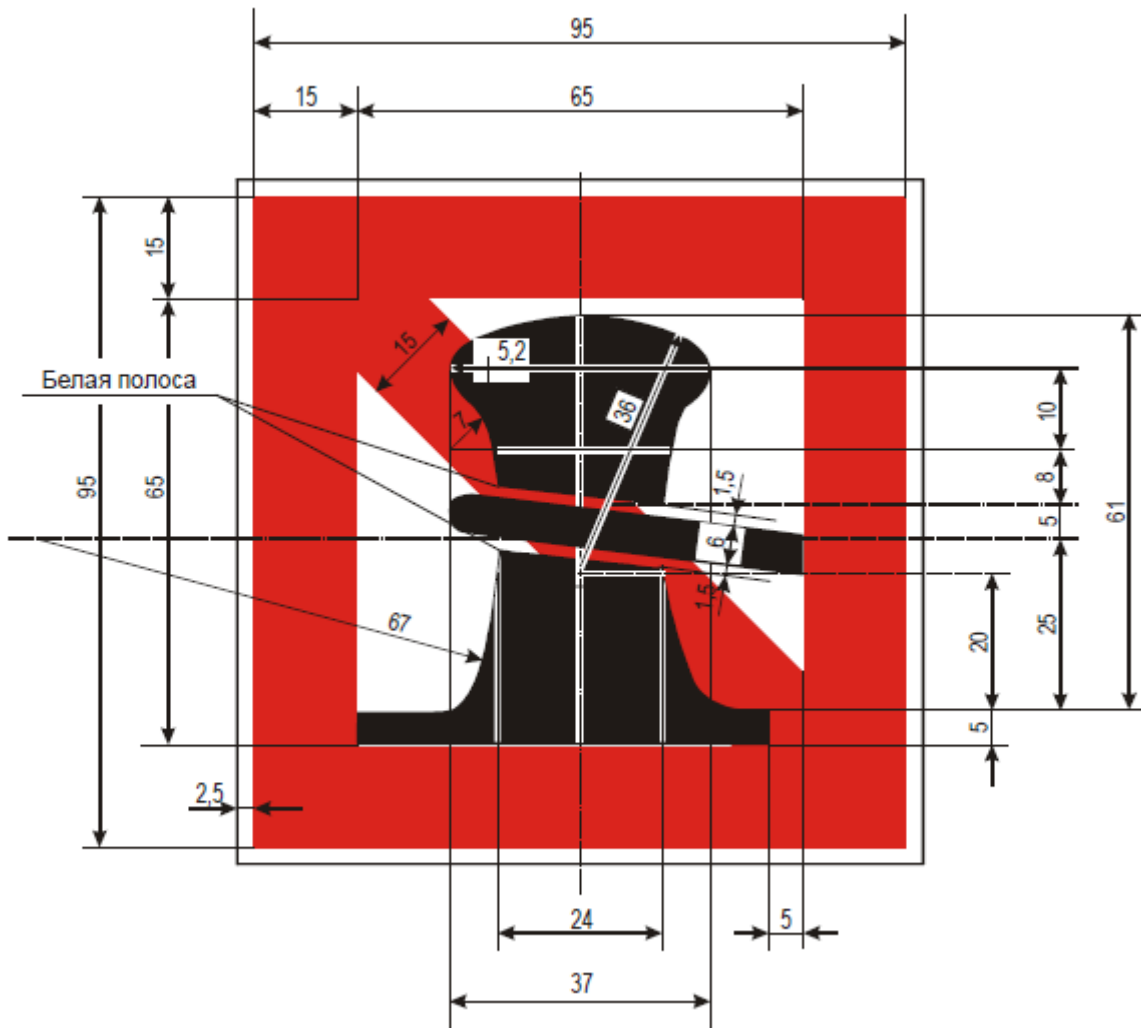

**A.8**

(No turning)

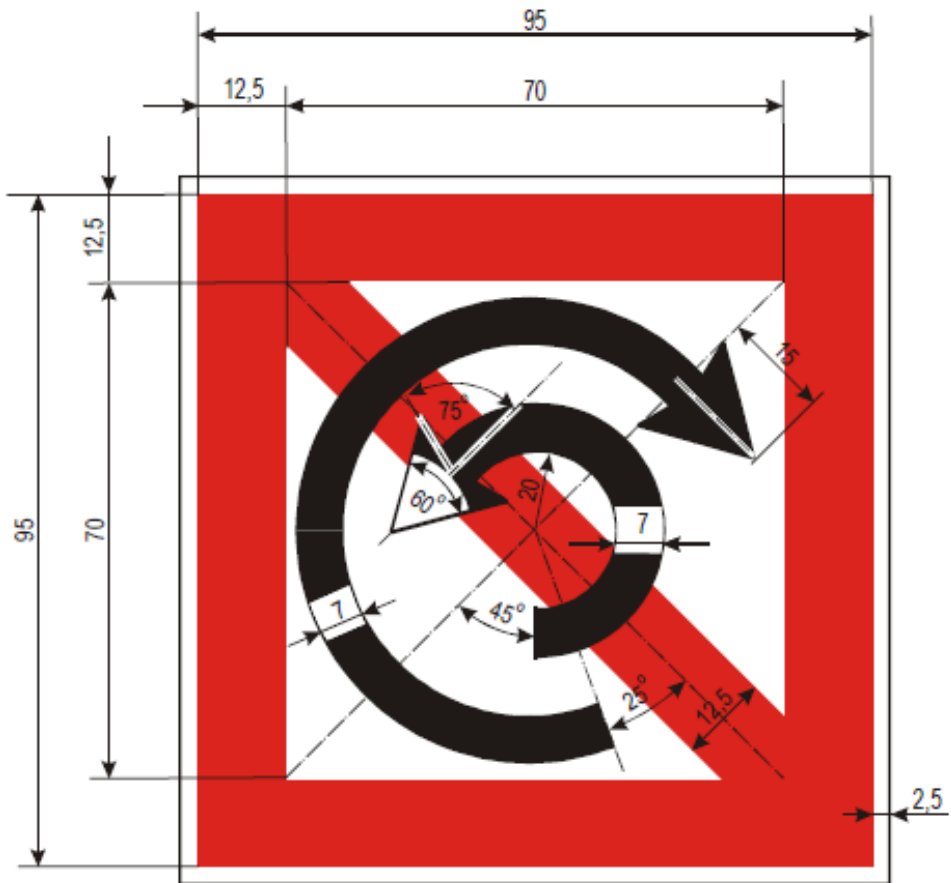

**A.9a**

(Do not create wash likely to cause damage)

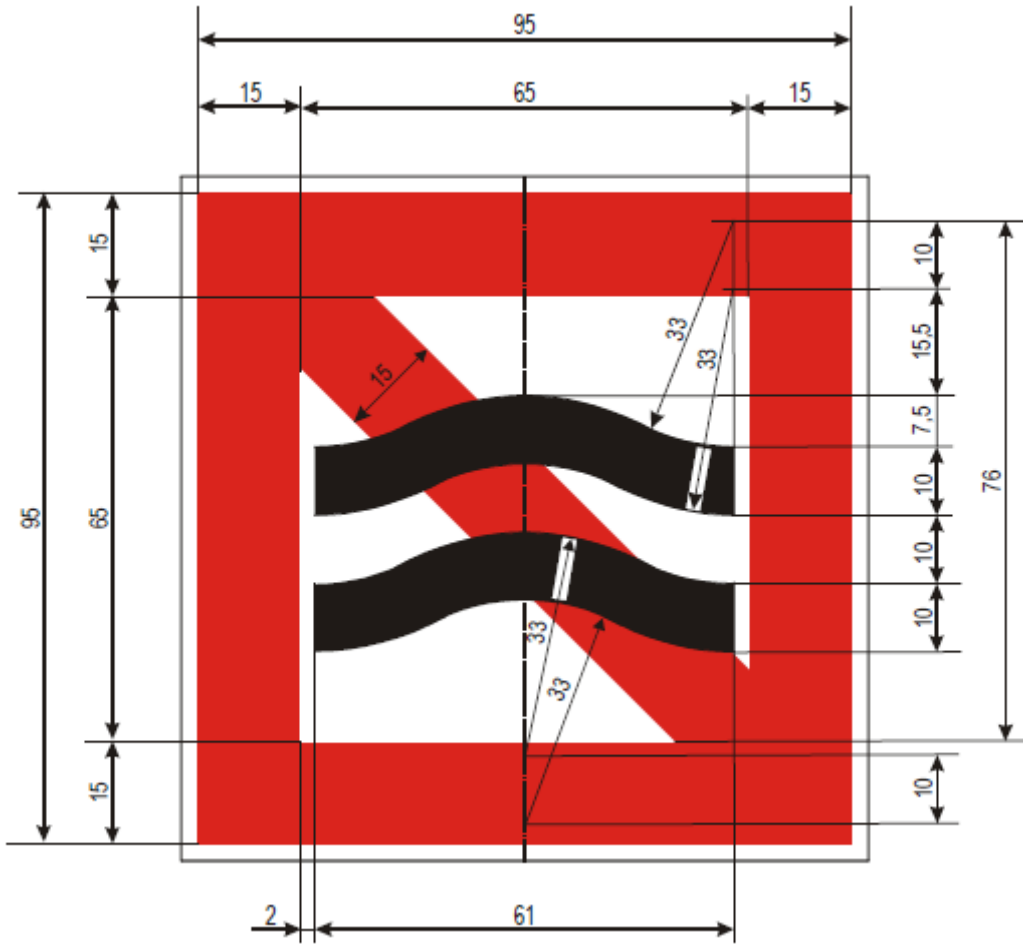

**A.10**

(No passing outside the area marked (in openings of bridges or weirs))

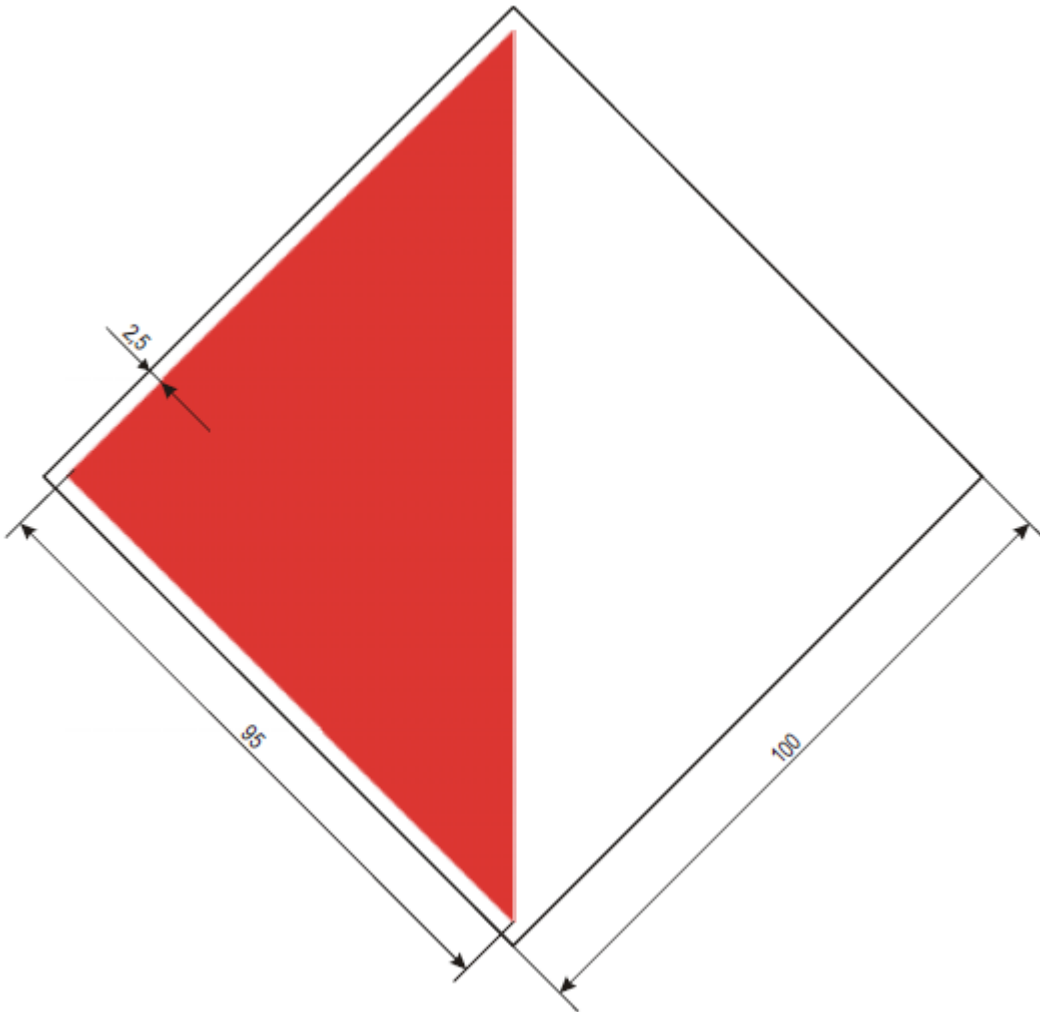



**A.12**

(Motorized craft prohibited)

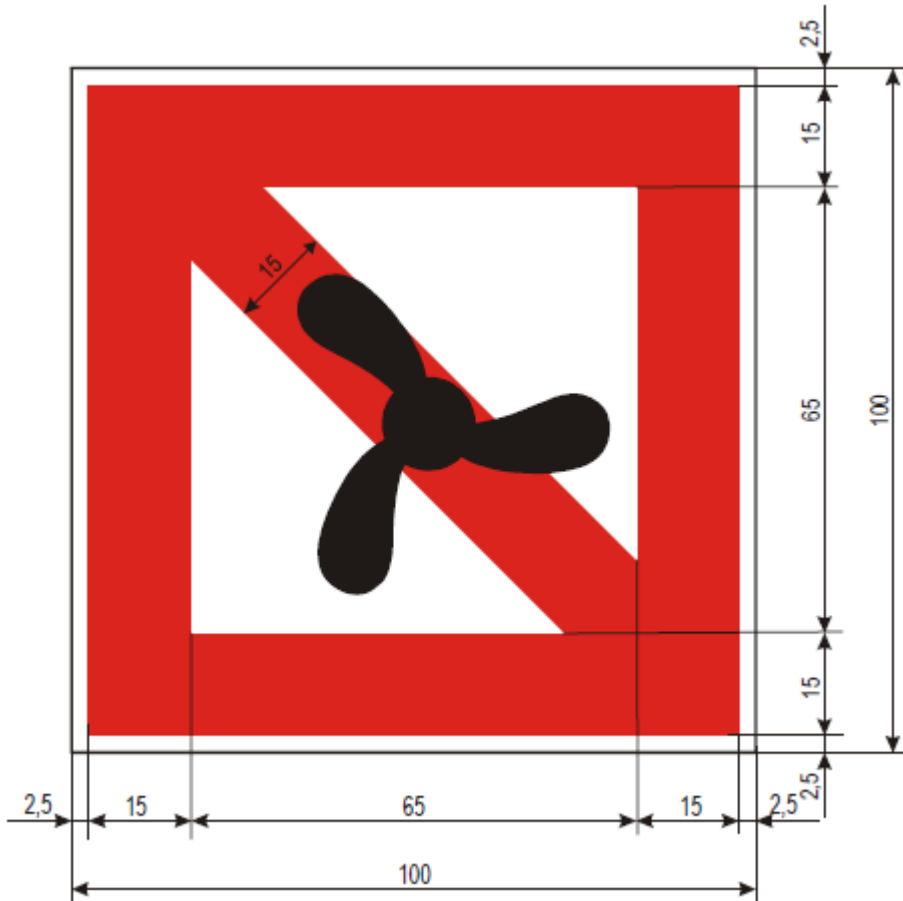

A.13

(All sports or pleasure craft prohibited)

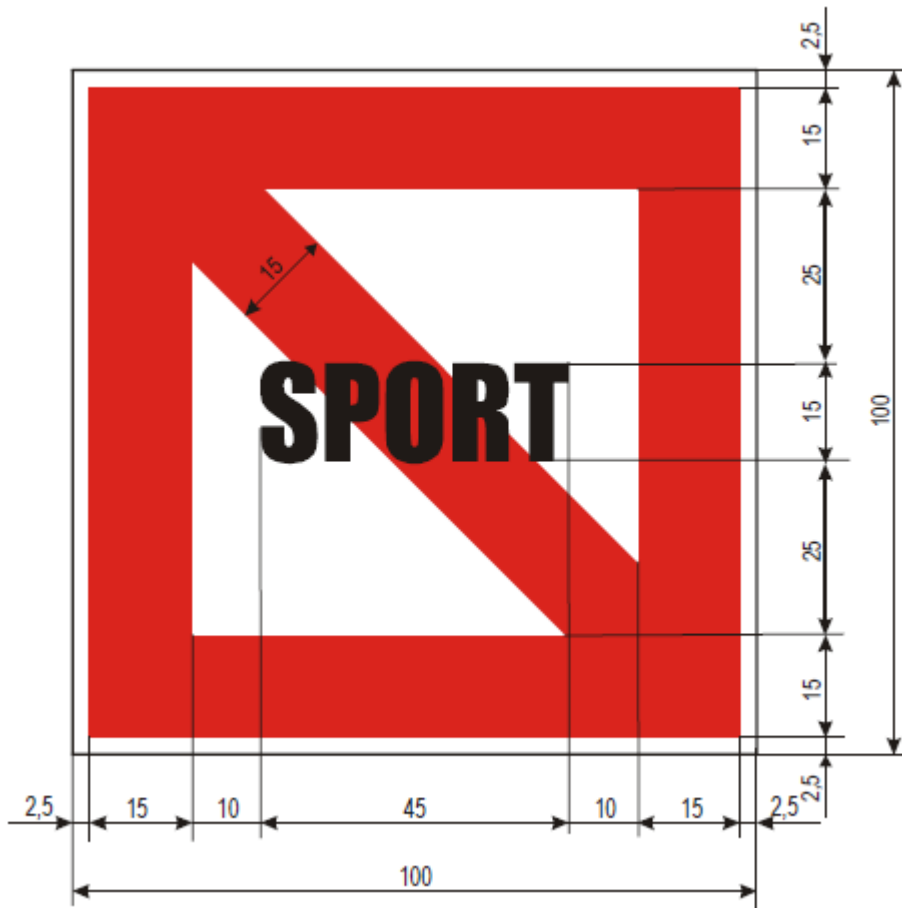

**A.14**

(Water skiing prohibited)

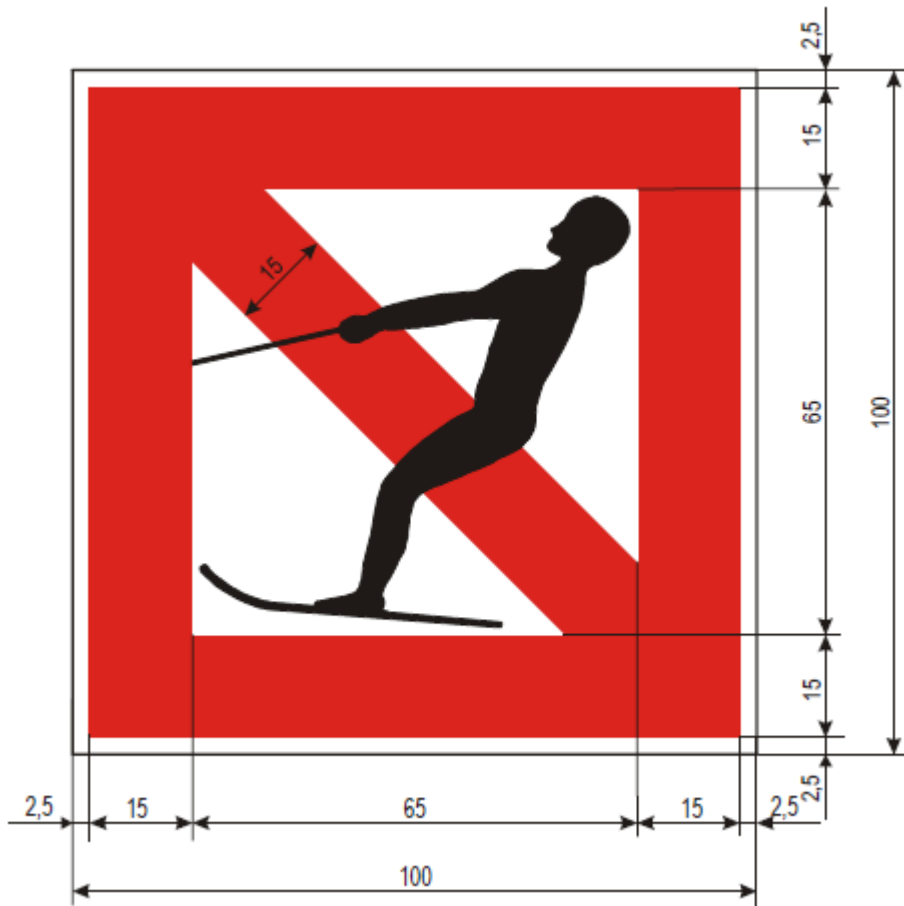

**A.15**

(Sailing vessels prohibited)

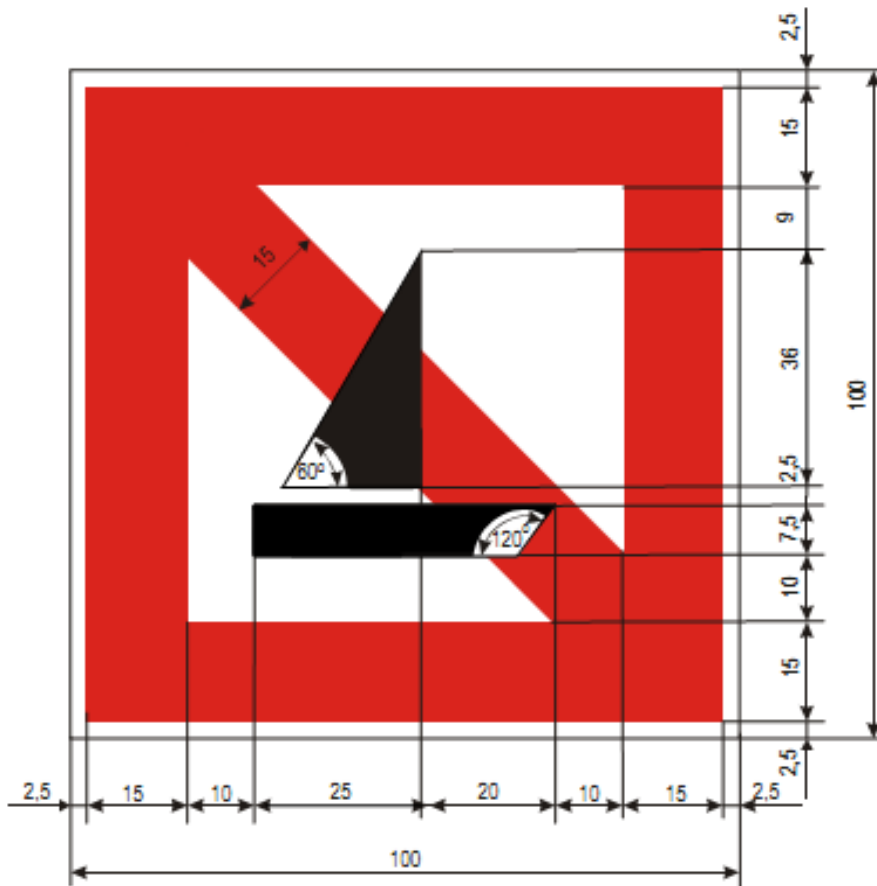

### A.16

(All craft other than motorized vessels or sailing craft prohibited)

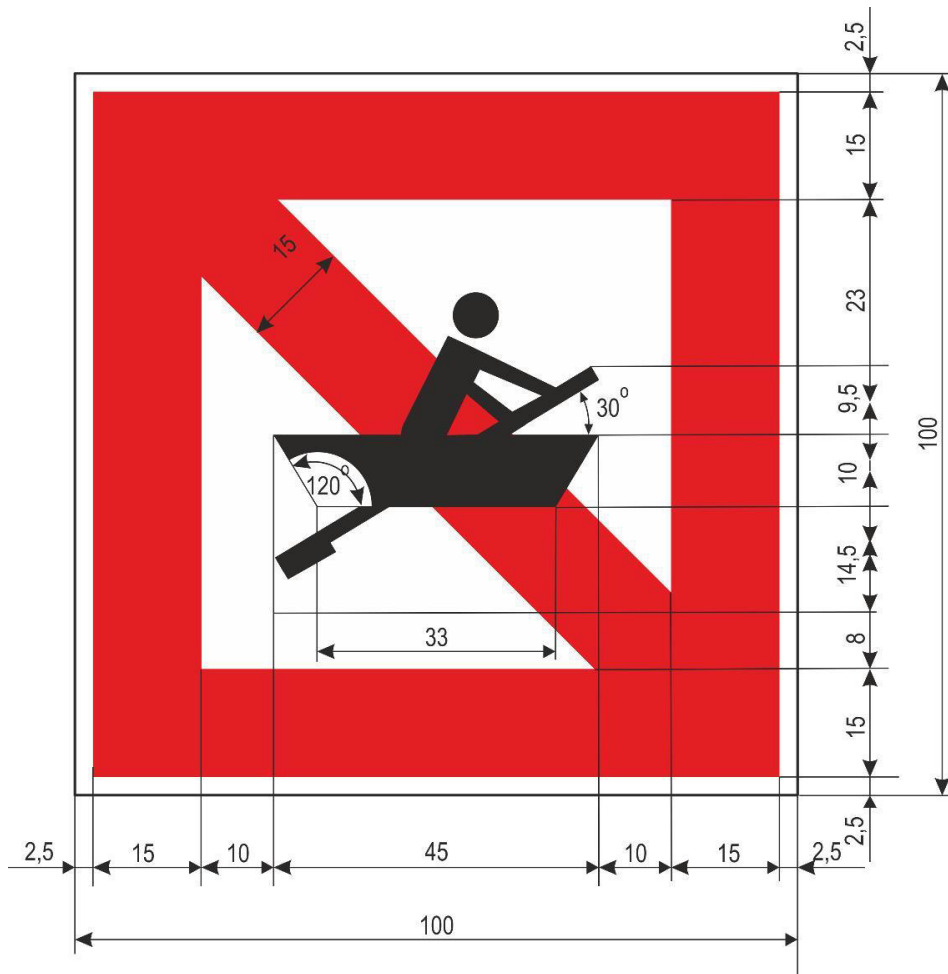

A.17

(Use of sailboats prohibited)

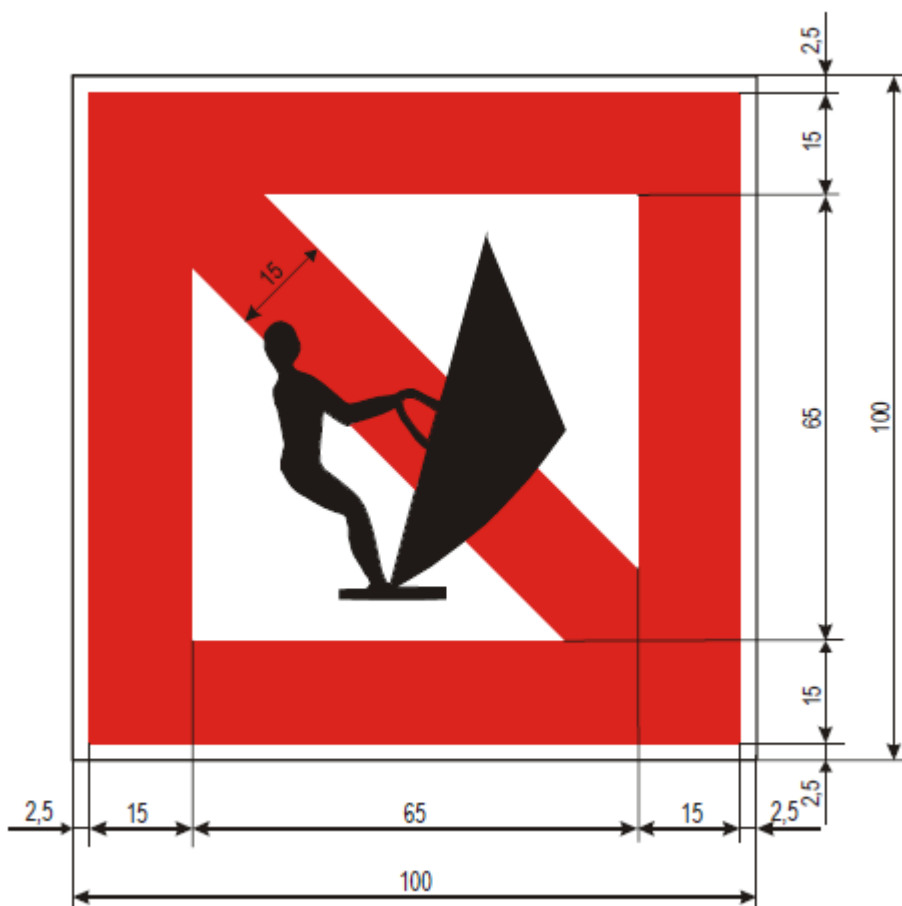

**A.18**

(End of zone authorized for high speed navigation of small sport and pleasure craft)

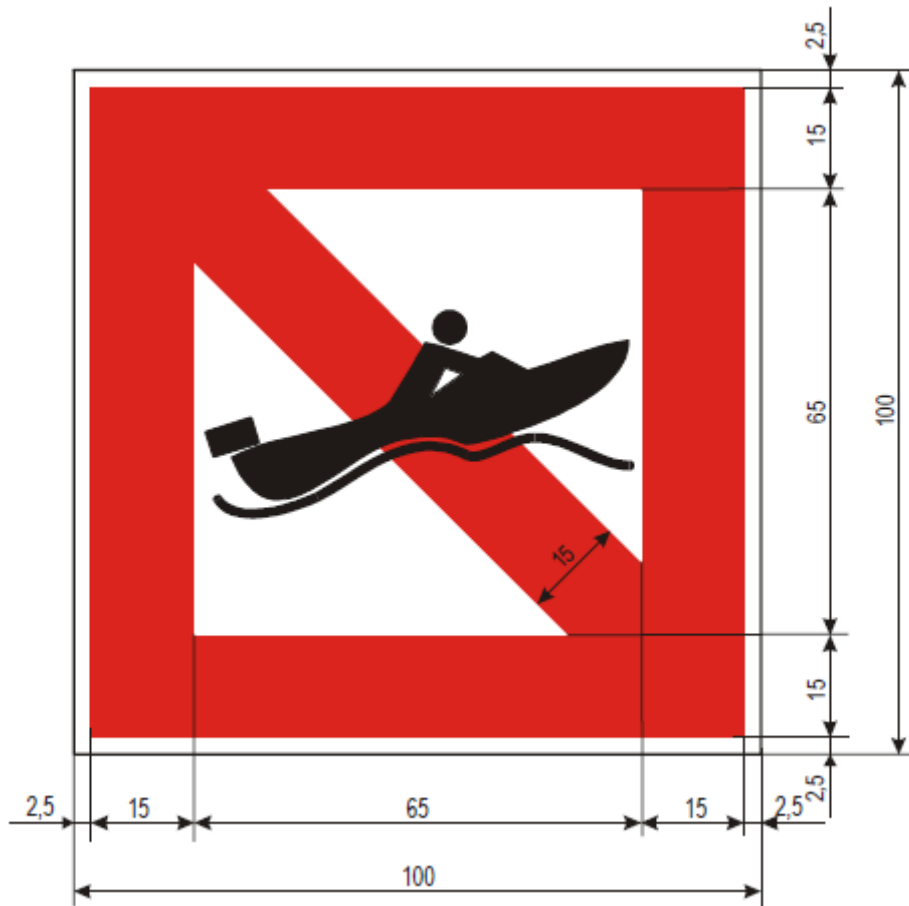

**A.19**

(No launching or beaching of vessels)

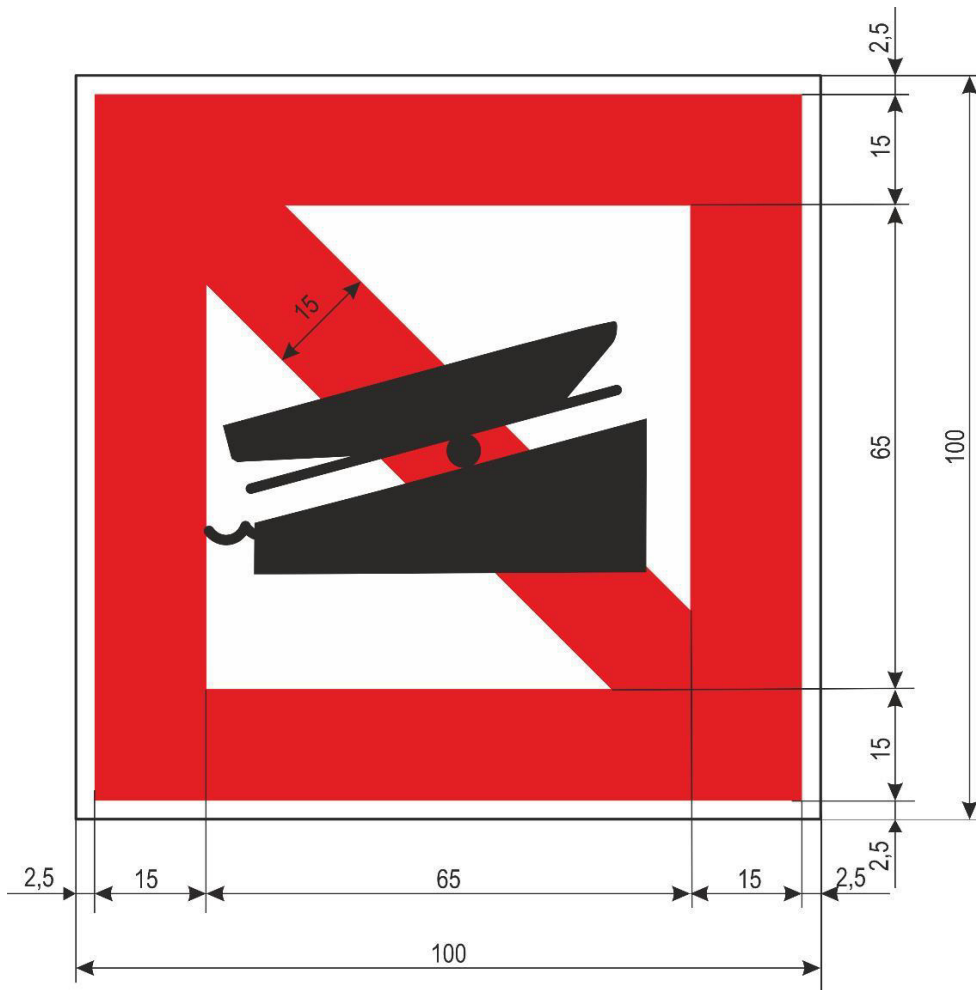



**A.20**

(Water bikes prohibited)

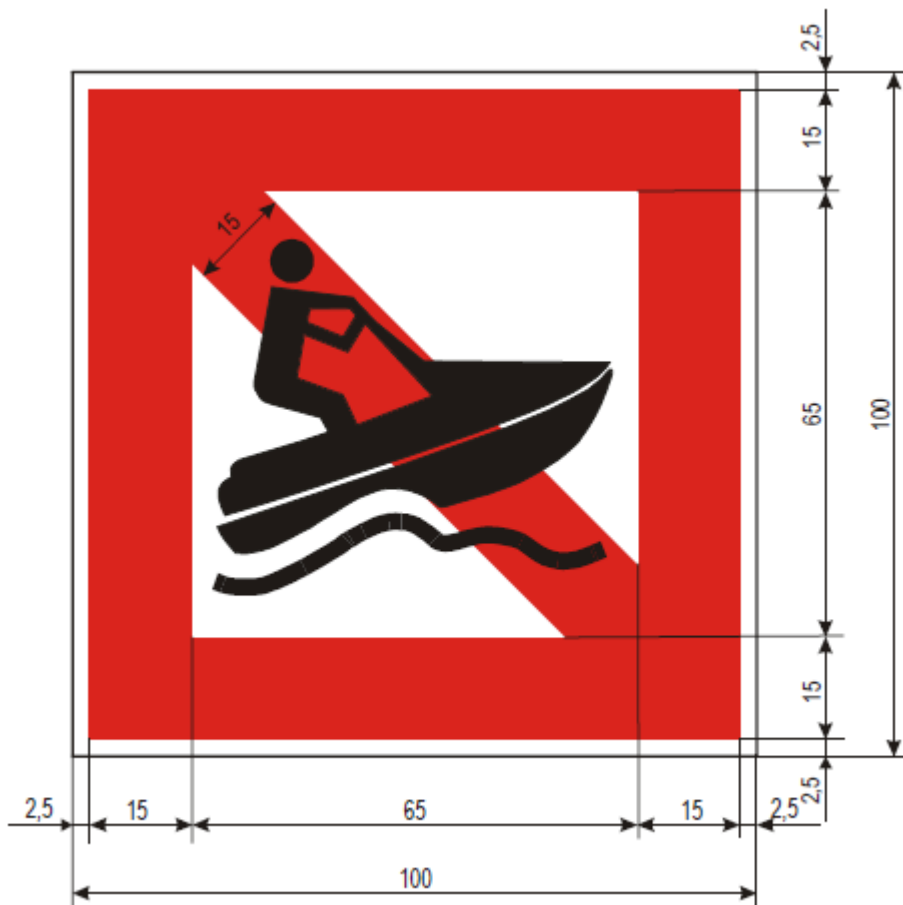

**B. Mandatory signs**

**B.1 Proceed in the direction shown by the arrow**

(Proceed in the direction shown by the arrow)

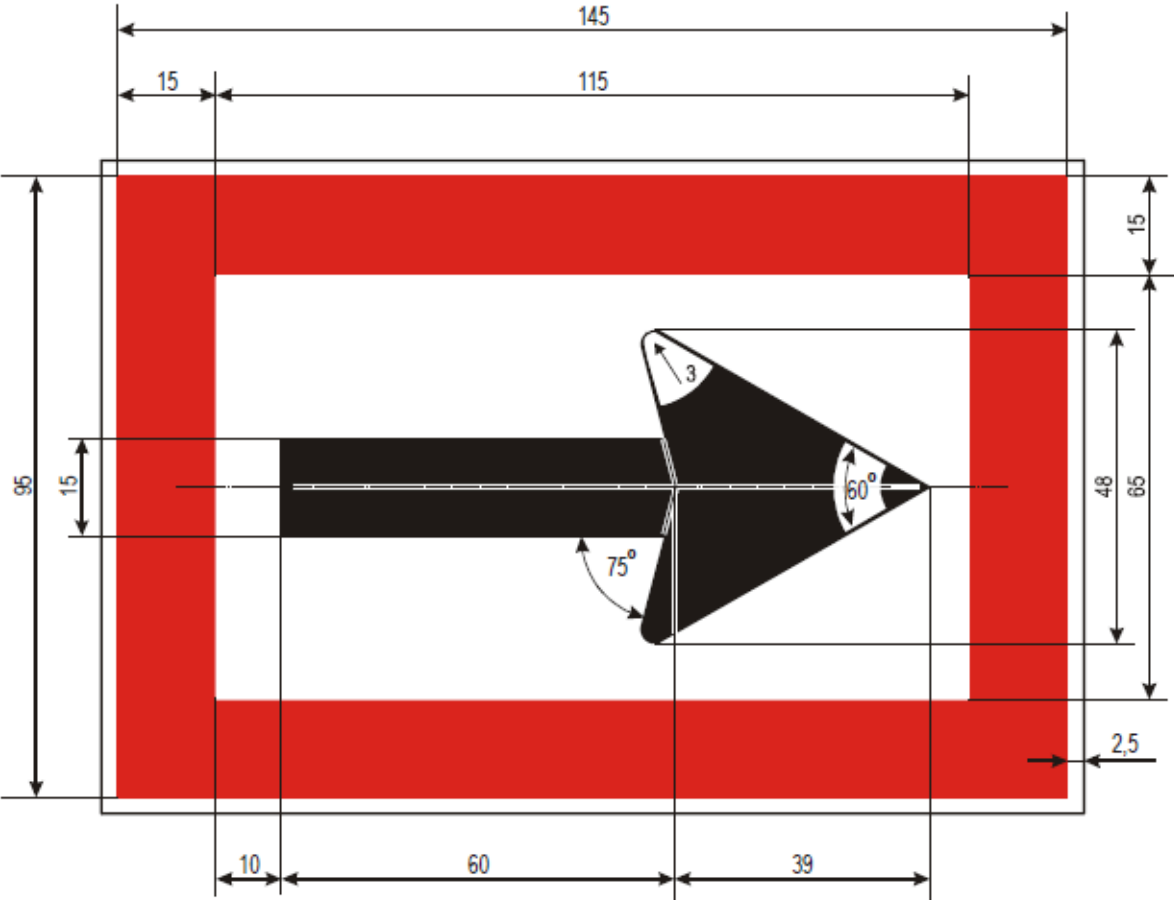

**B.2a**

(Move to the side of the fairway on your port side)

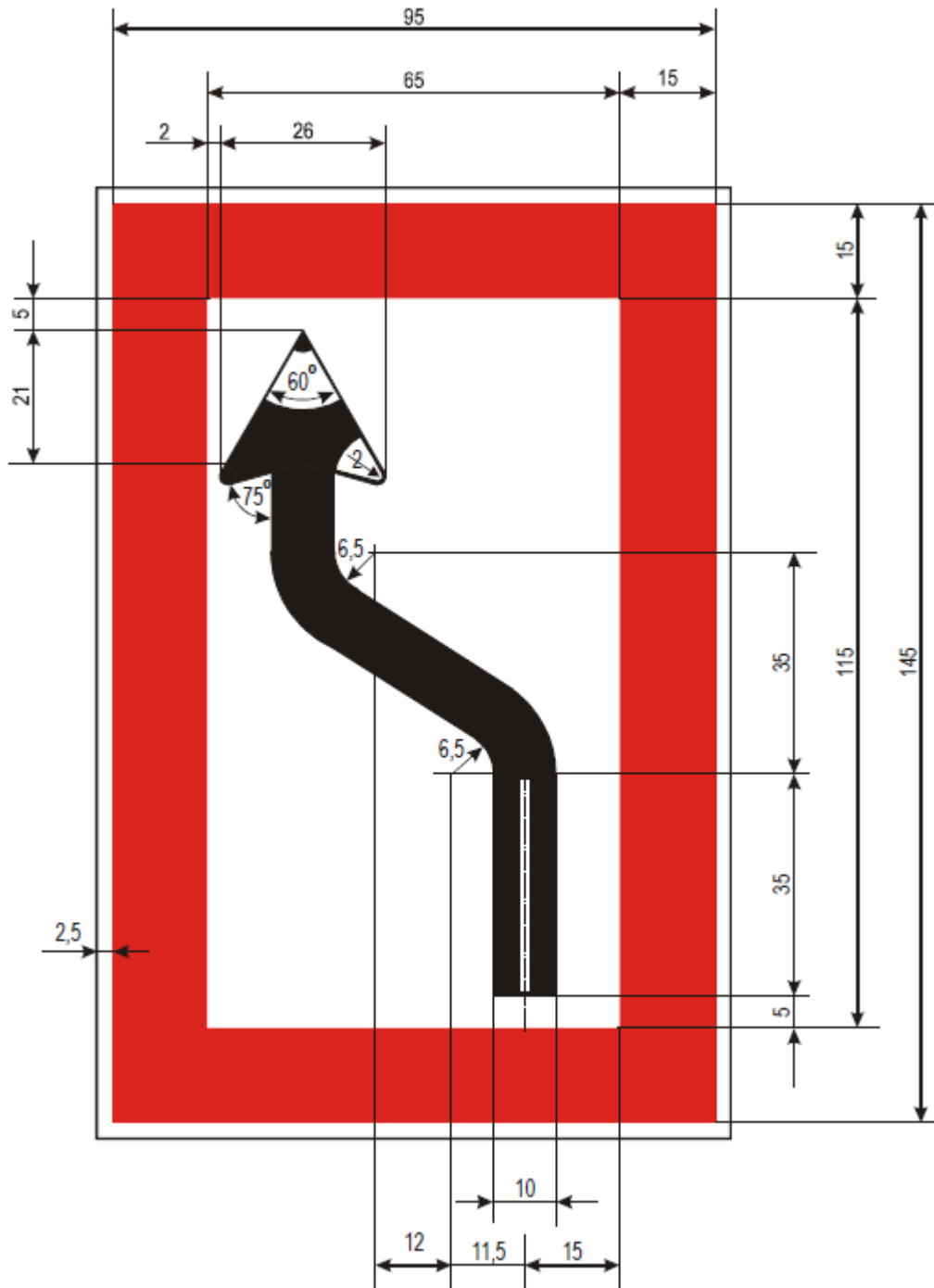

**B.2b**

(Move to the side of the fairway on your starboard side)

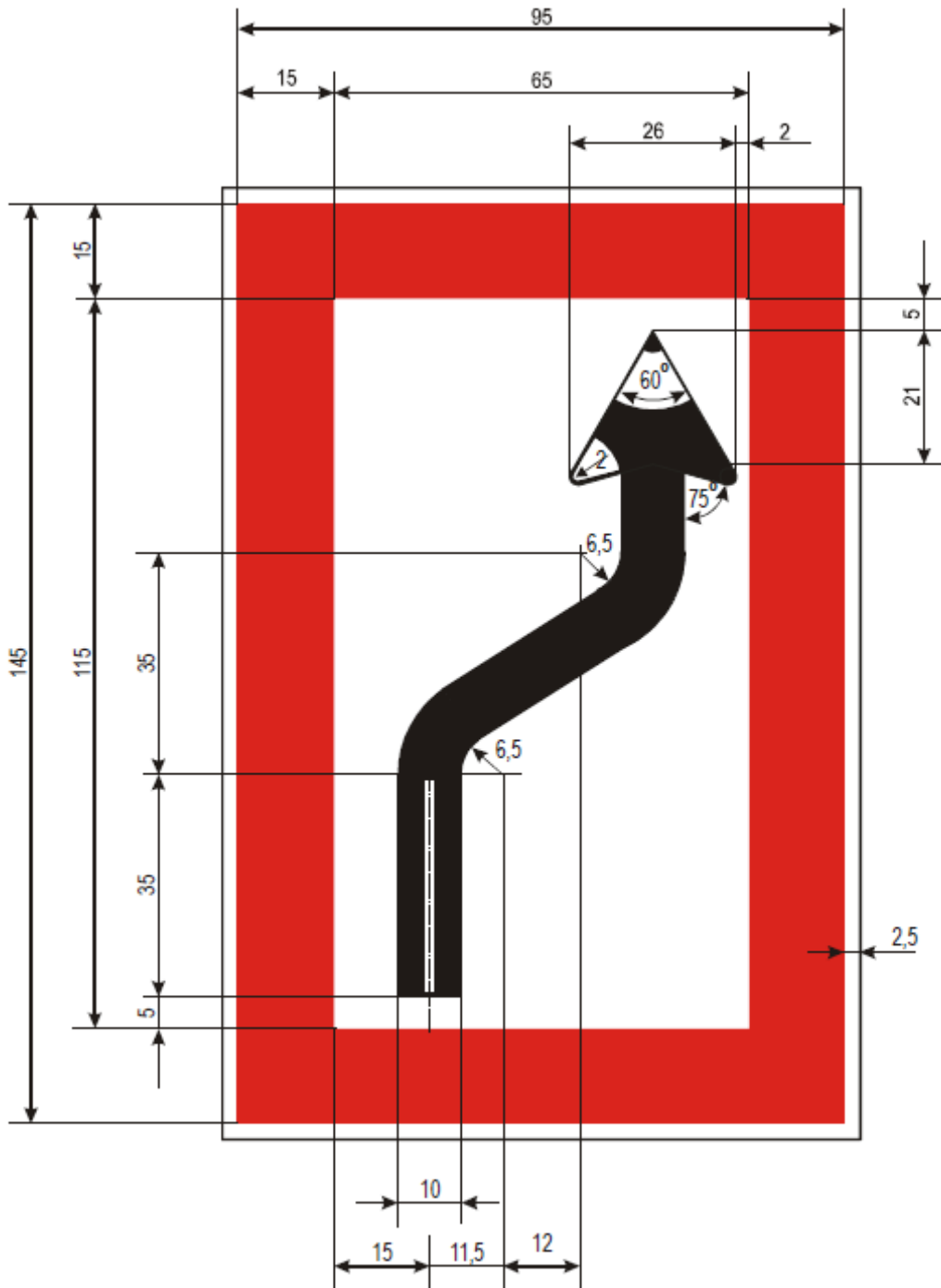

### B.3a

(Keep to the side of the fairway on your port side)

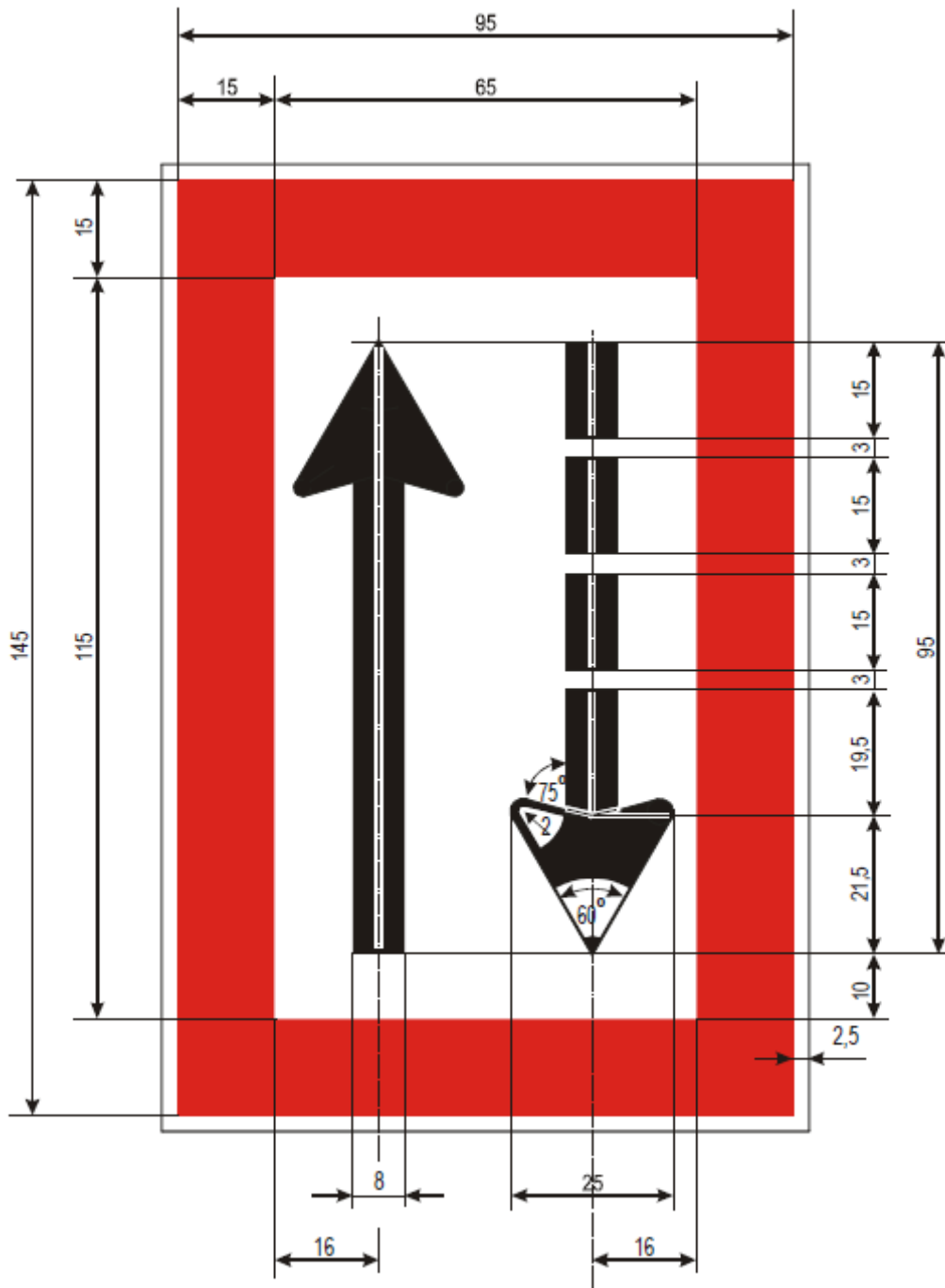

### B.3b

(Keep to the side of the fairway on your starboard side)

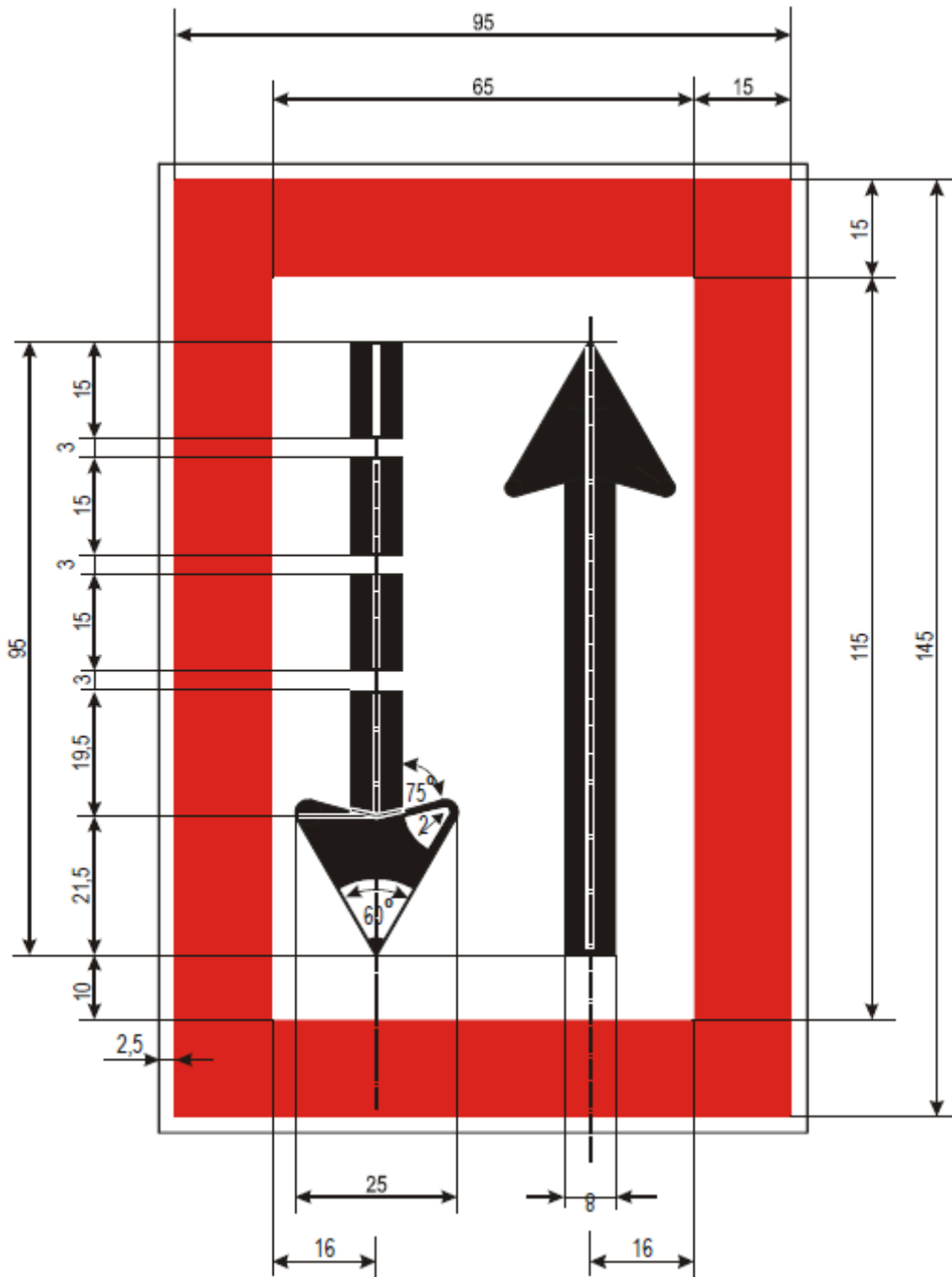

**B.4a**

(Cross fairway to port)

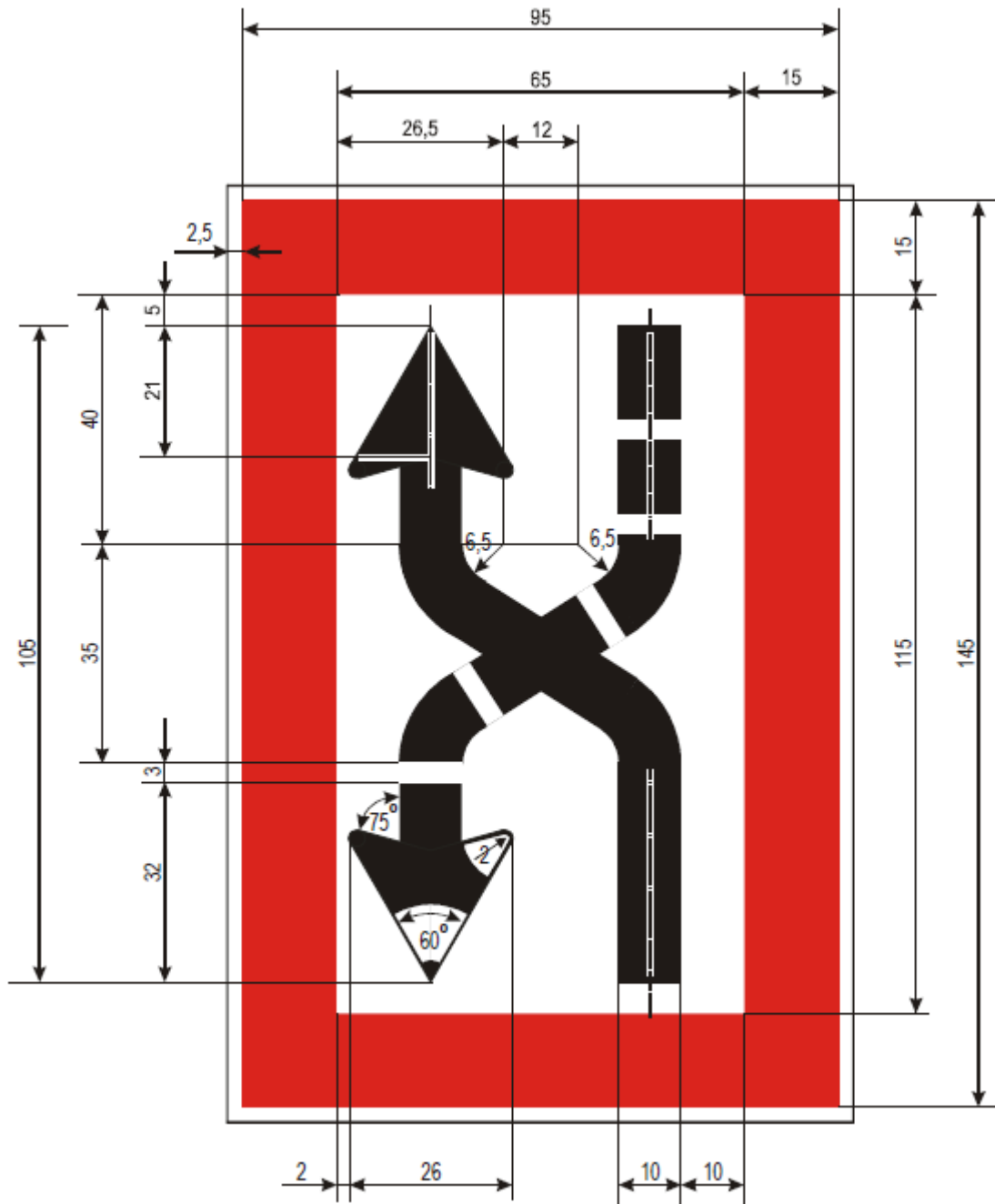

**B.4b**

(Cross fairway to starboard)

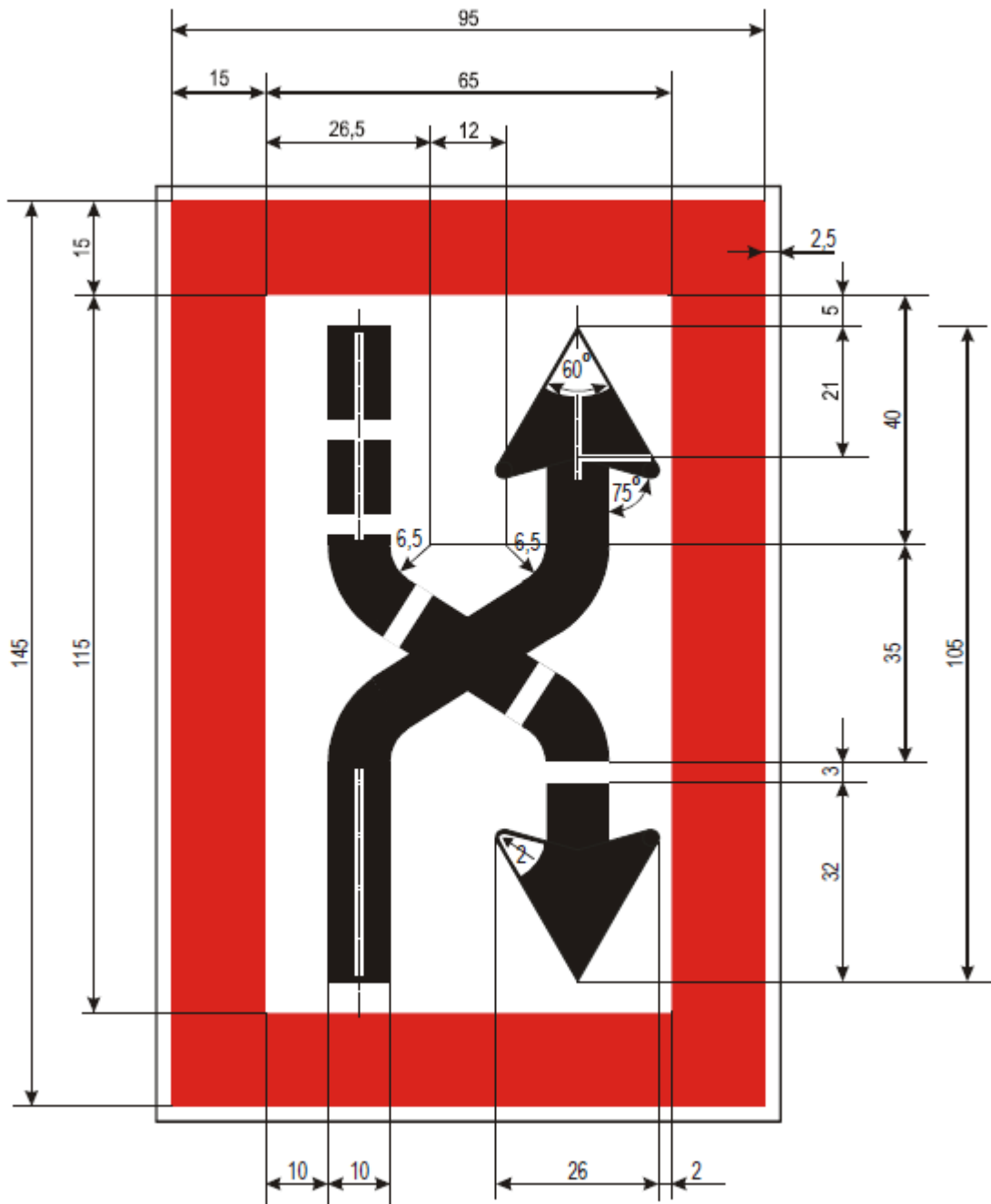



**B.5**

(Stop as prescribed in the Regulations)

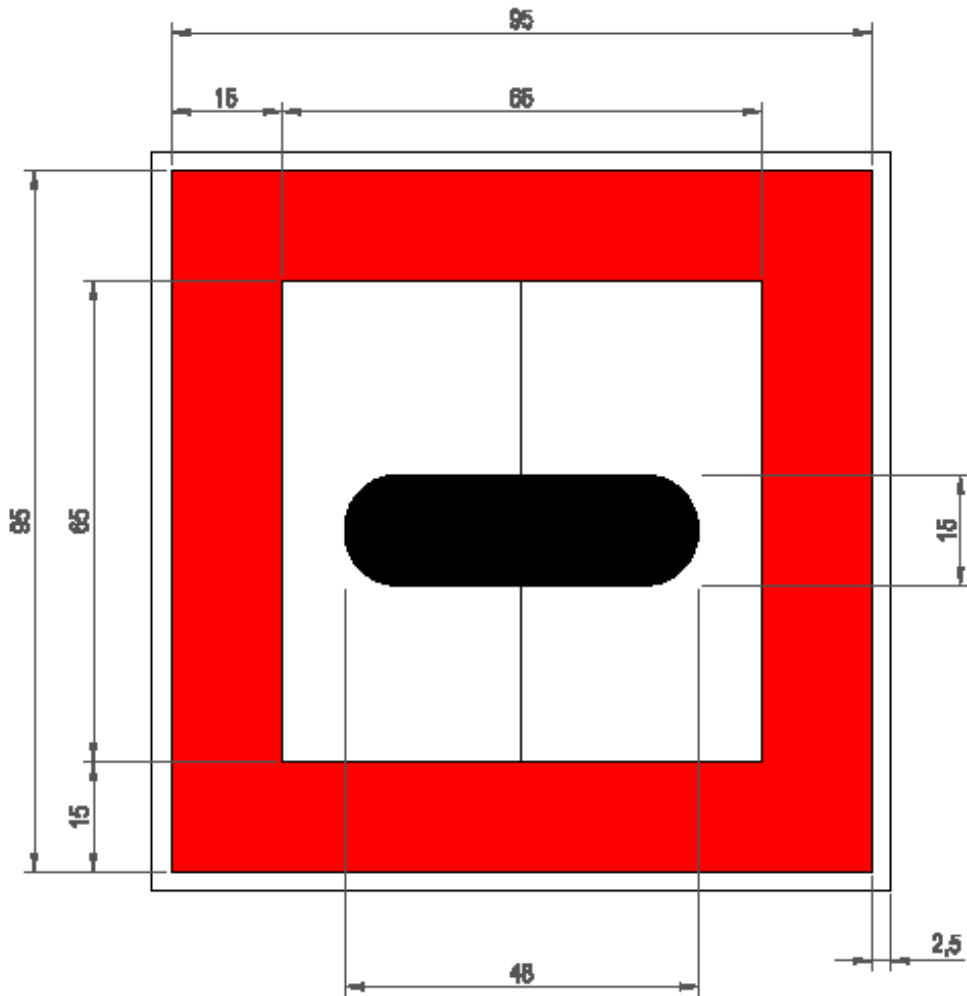

### B.6

(Do not exceed the speed indicated (in km/h))

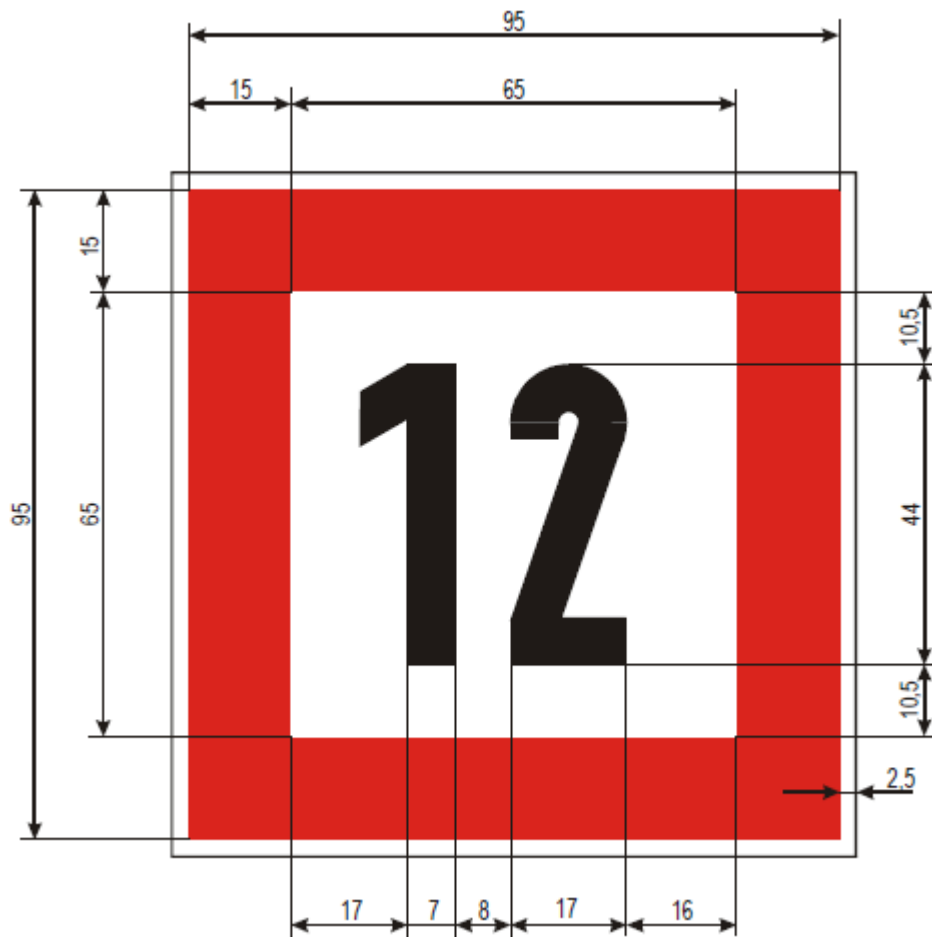

**B.7**

(Give a sound signal)

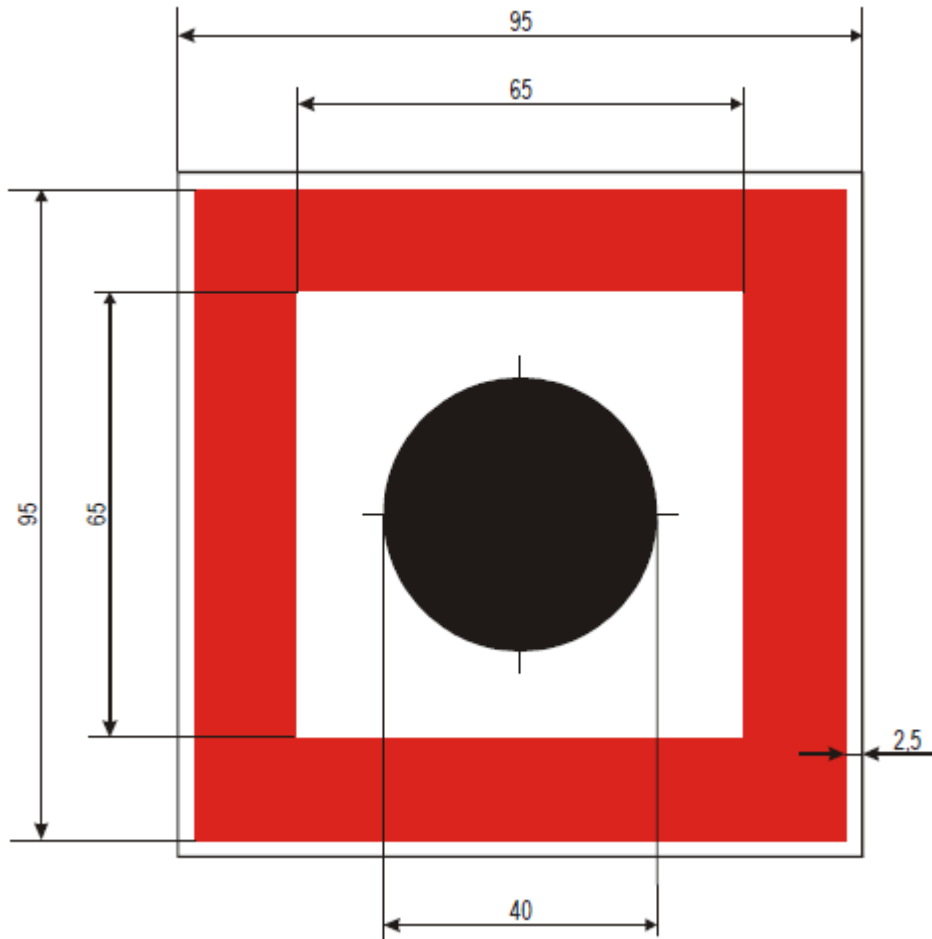

### B.8

(Keep a particularly sharp lookout)

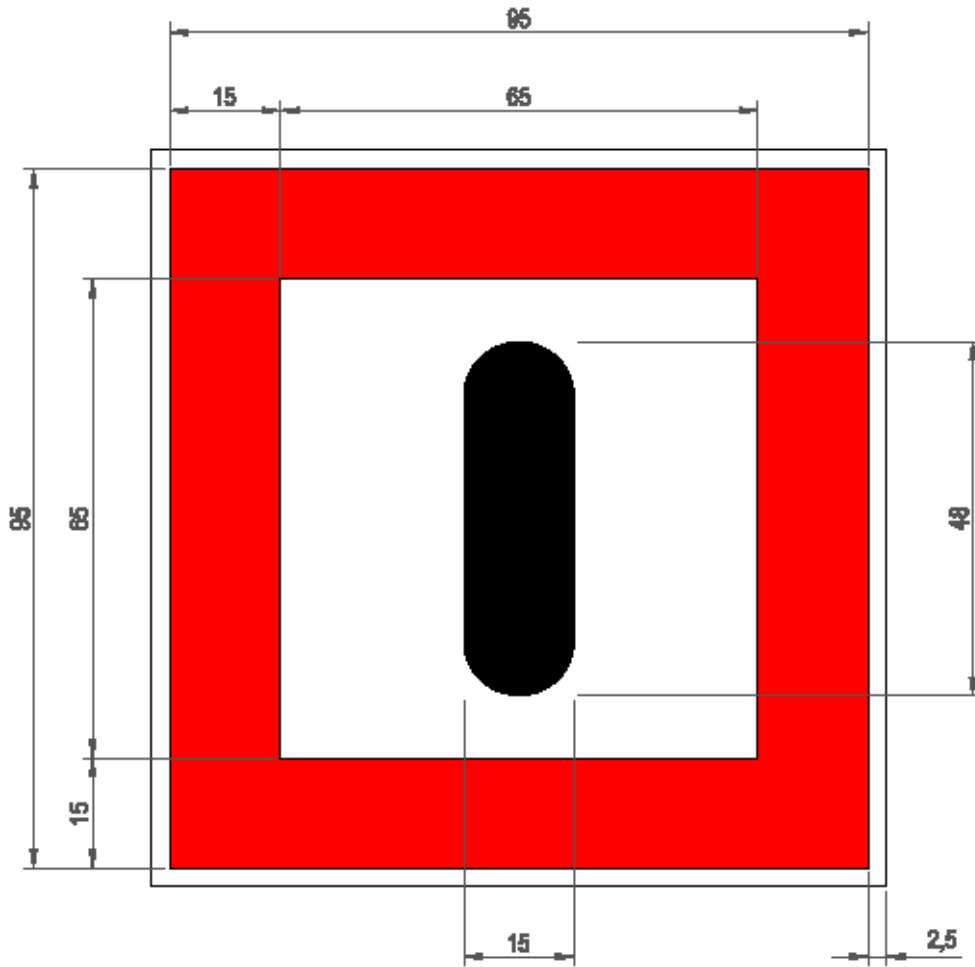

**B.9a**

(Do not enter or cross the main waterway until certain that this will not oblige vessels proceeding on it to change their course or speed)

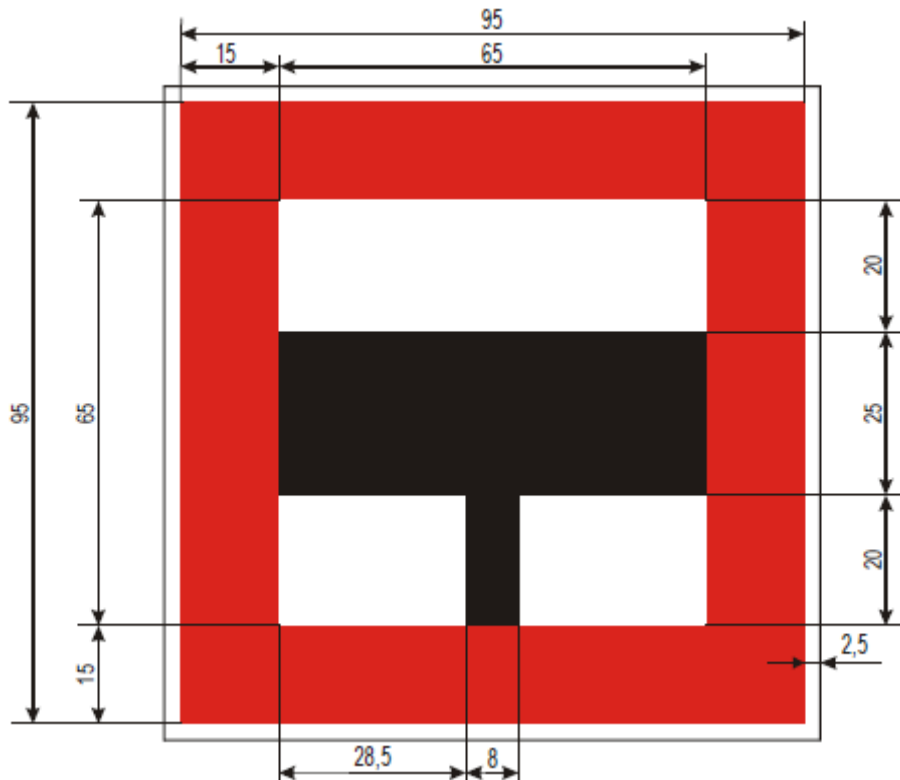

**B.9b**

(Do not enter or cross the main waterway until certain that this will not oblige vessels proceeding on it to change their course or speed)

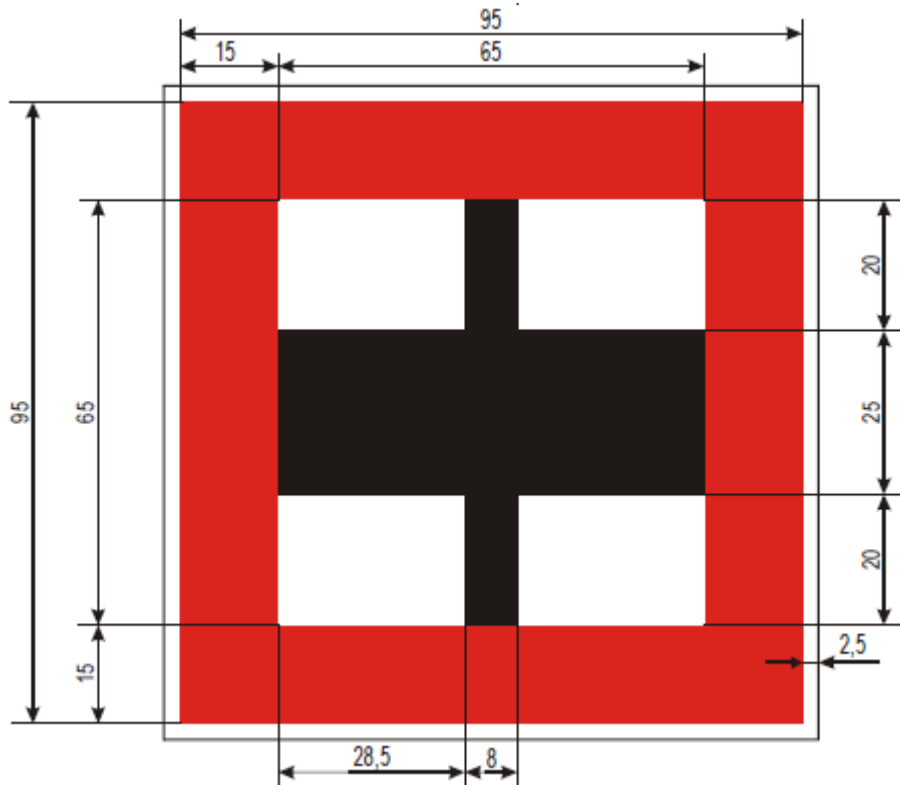

**B.11a**

(Obligation to enter into radiotelephone link)

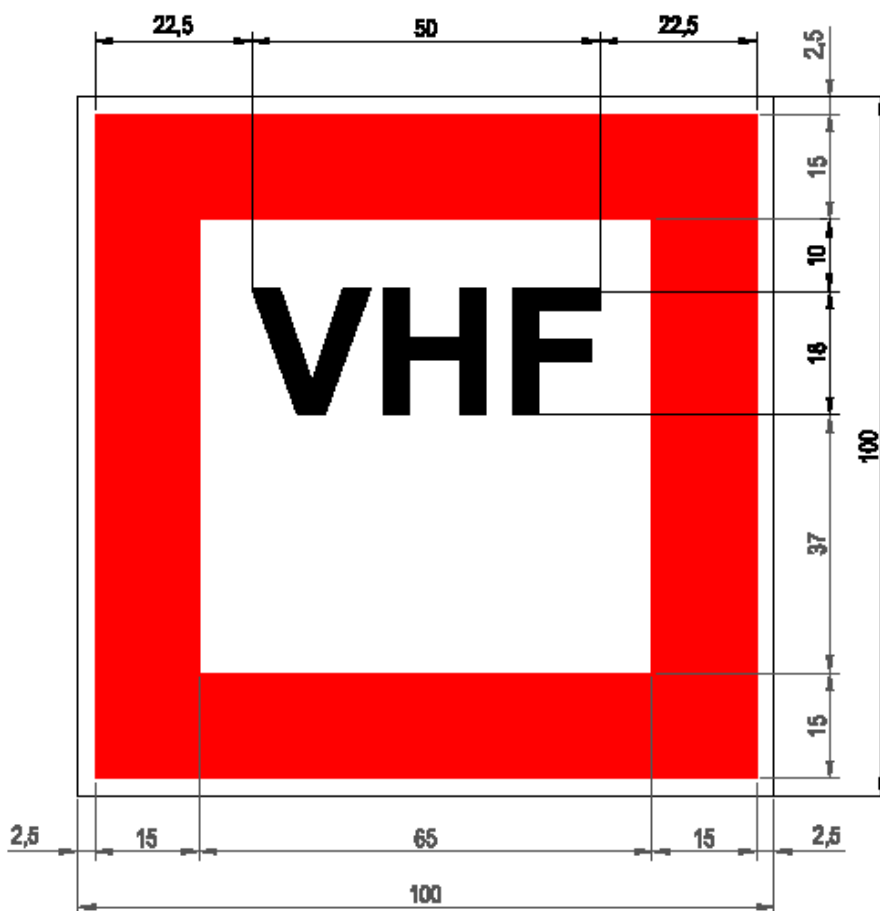

**B.11b**

(Obligation to enter into a radiotelephone link on the channel as indicated on the board)

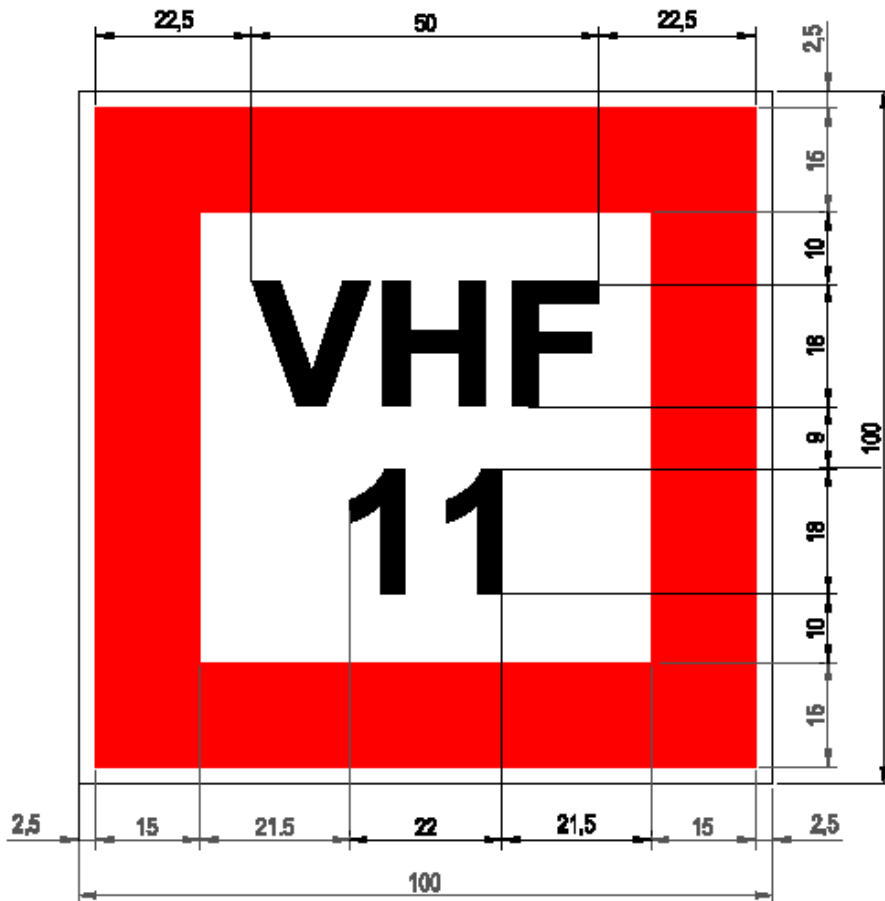



C. Restrictive signs

C.1

(Depth of water limited)

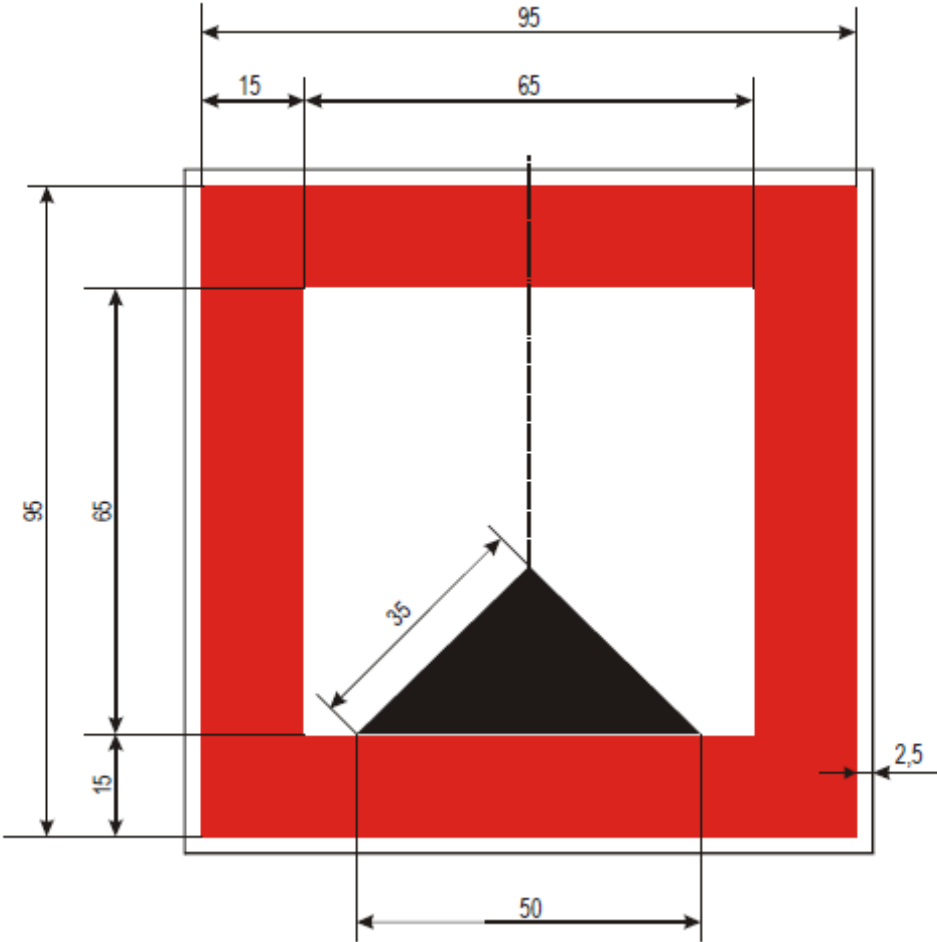

C.1b

(Depth of water limited)

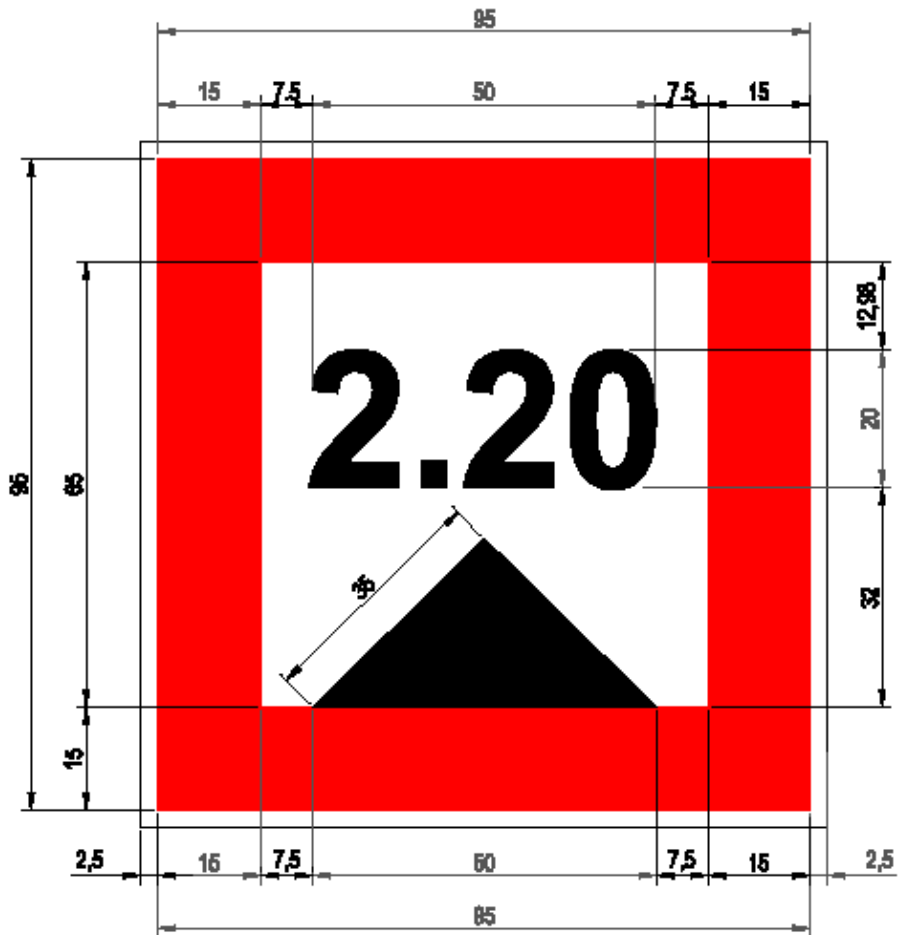

**C.2a**

(Headroom limited)

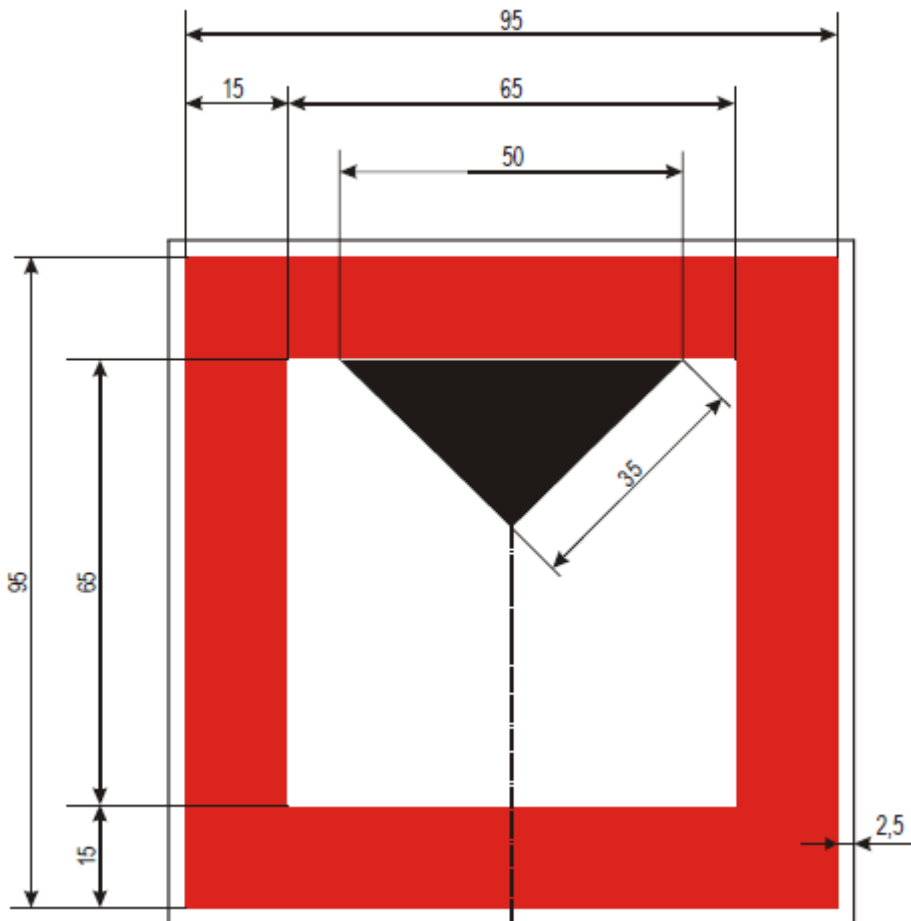

C.2b

(Headroom limited)

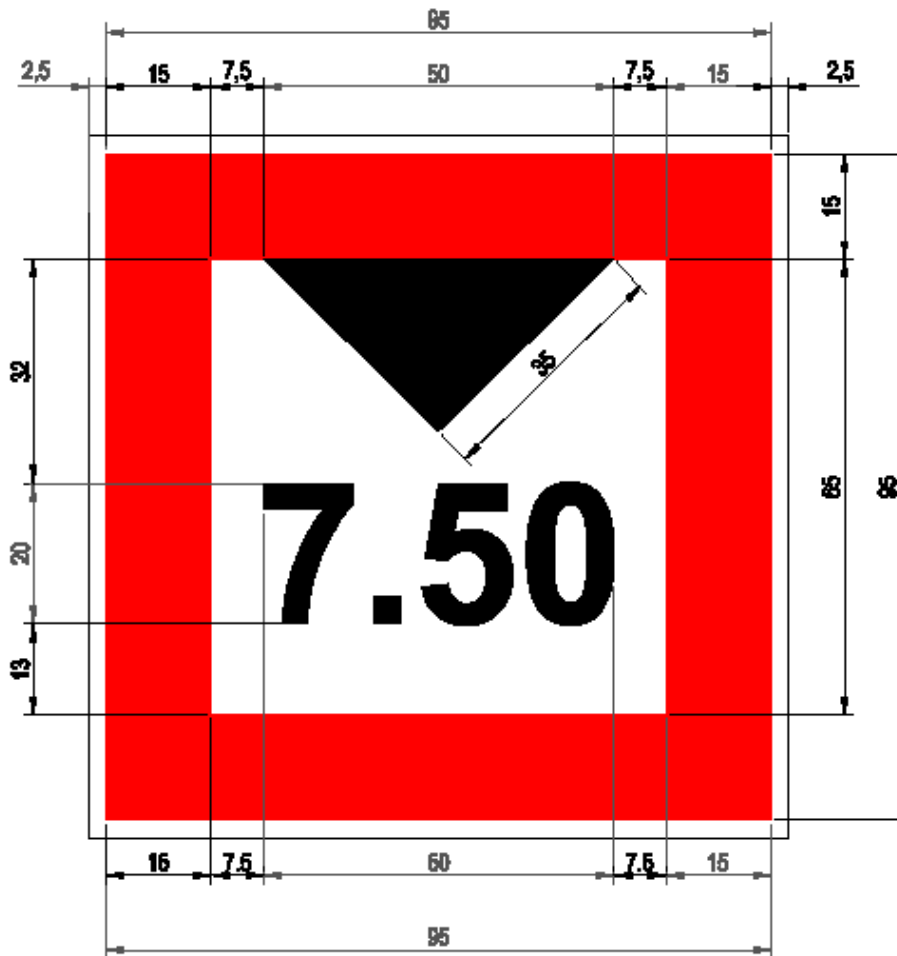

**C.3a**

(Width of passage or fairway limited)

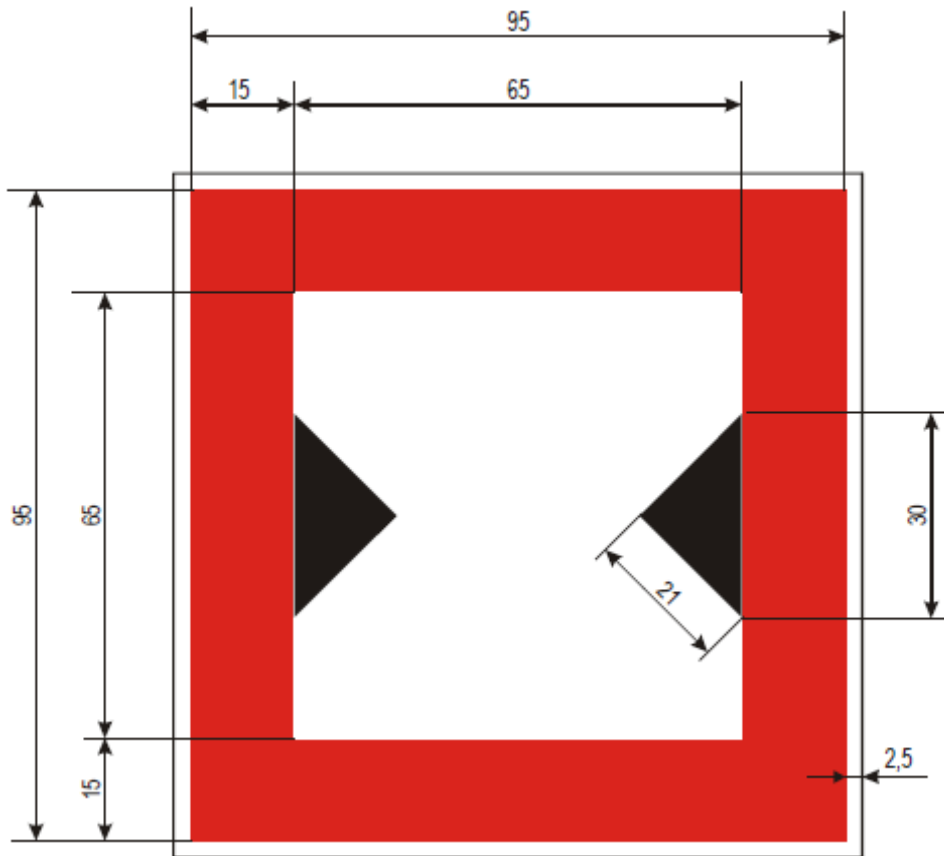

**C.3b**

(Width of passage or fairway limited)

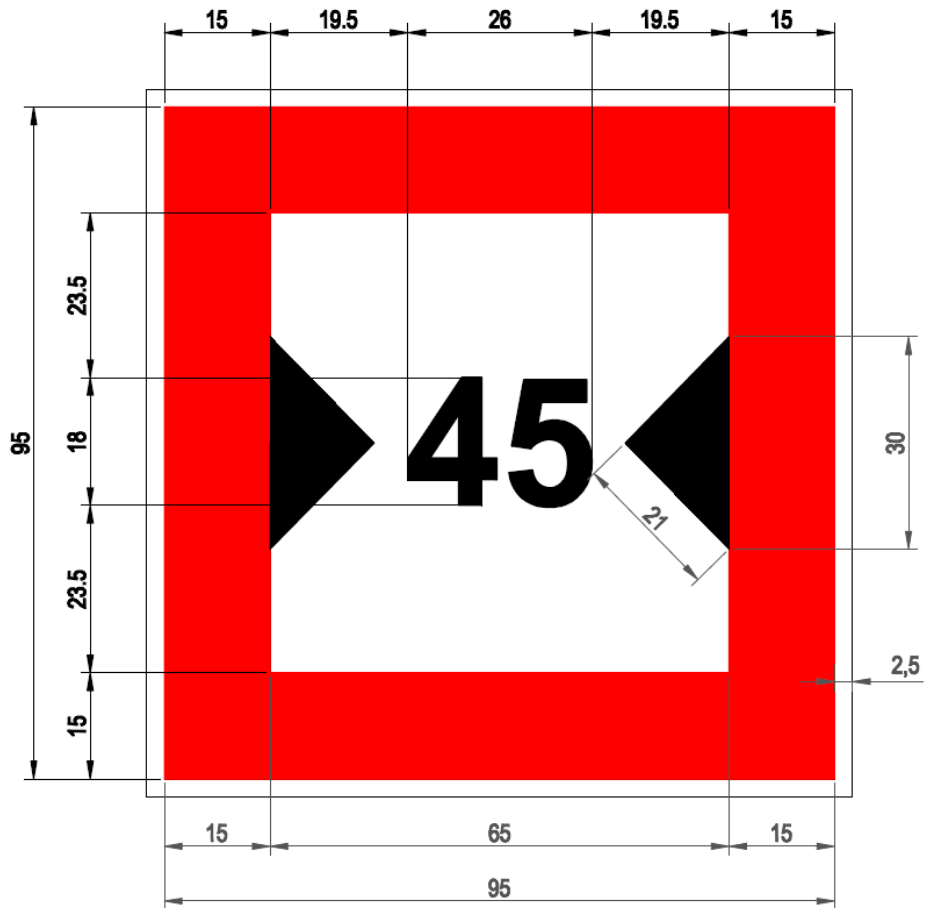

### C.4

(There are restrictions on navigation: make enquiries)

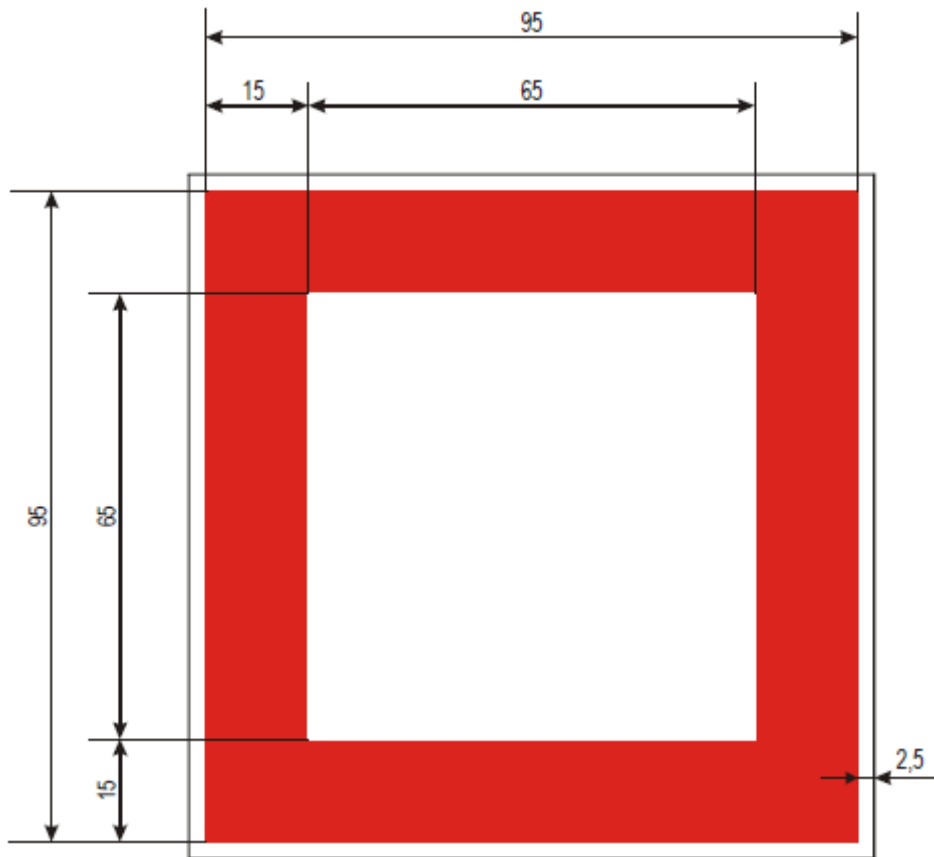

### C.5

(The fairway lies at a distance from the right (left) bank; the figure shown on the sign indicates the distance in meters, measured from the sign, to which vessels should keep)

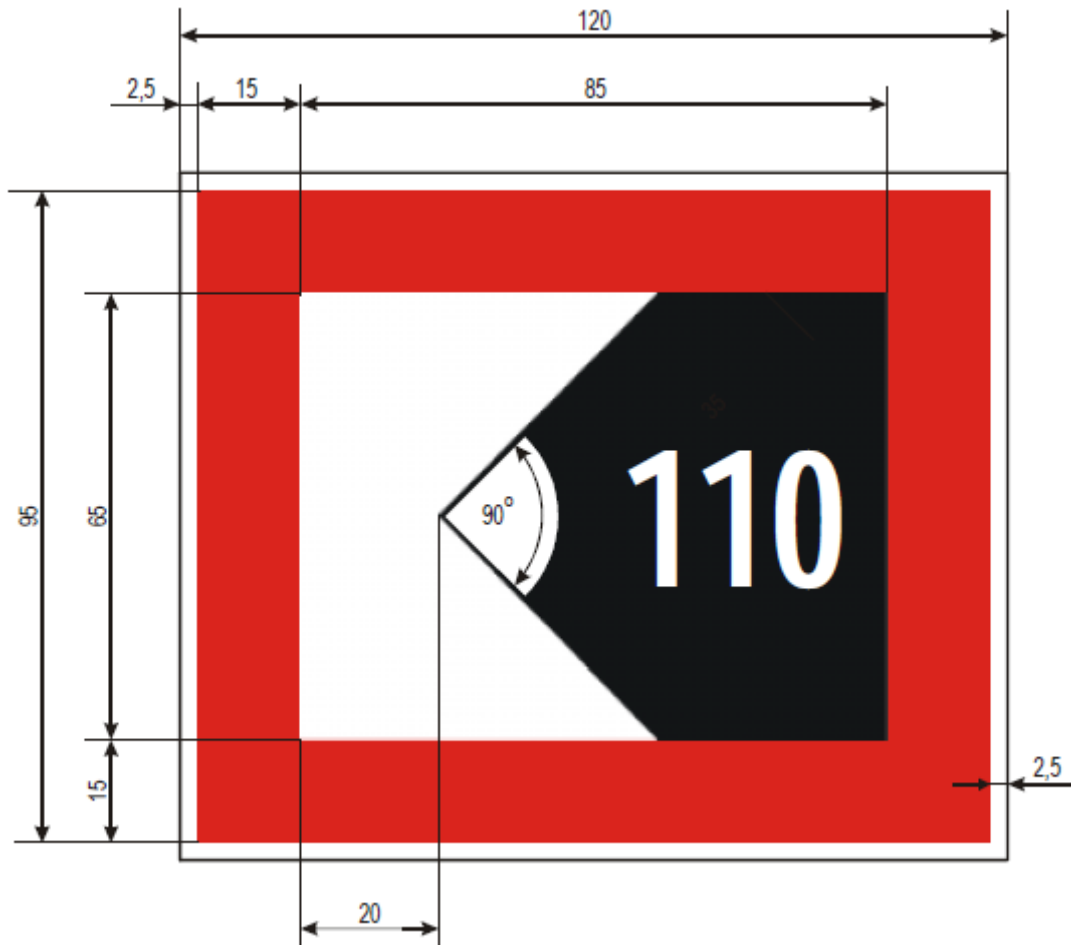



**D. Recommendatory sighs**

**D.1**

(Recommended fairway in both directions)

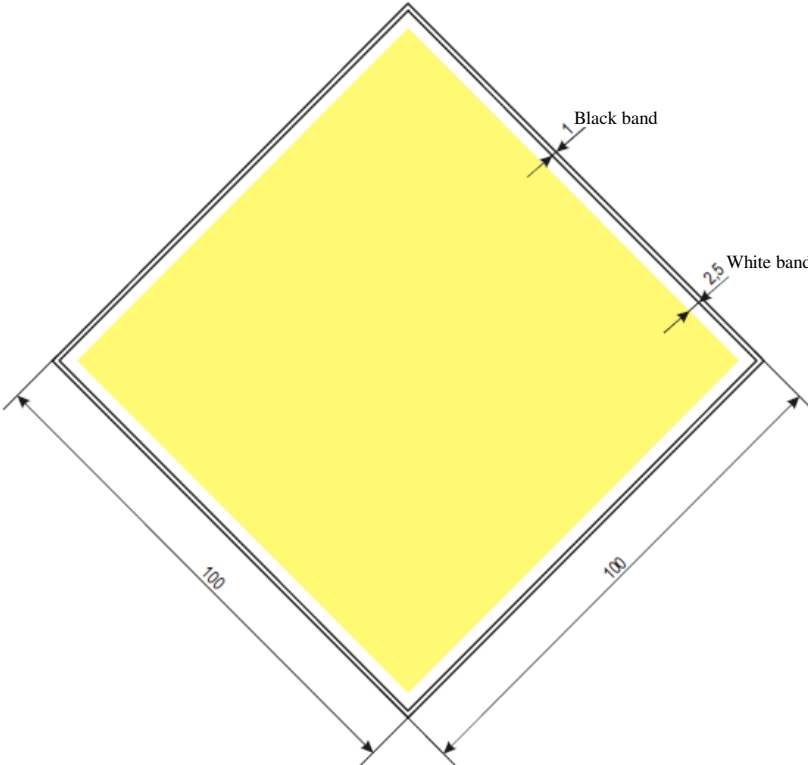

**D.1c**

(Recommended fairway (Only in the direction indicated (passage in the opposite direction prohibited)))

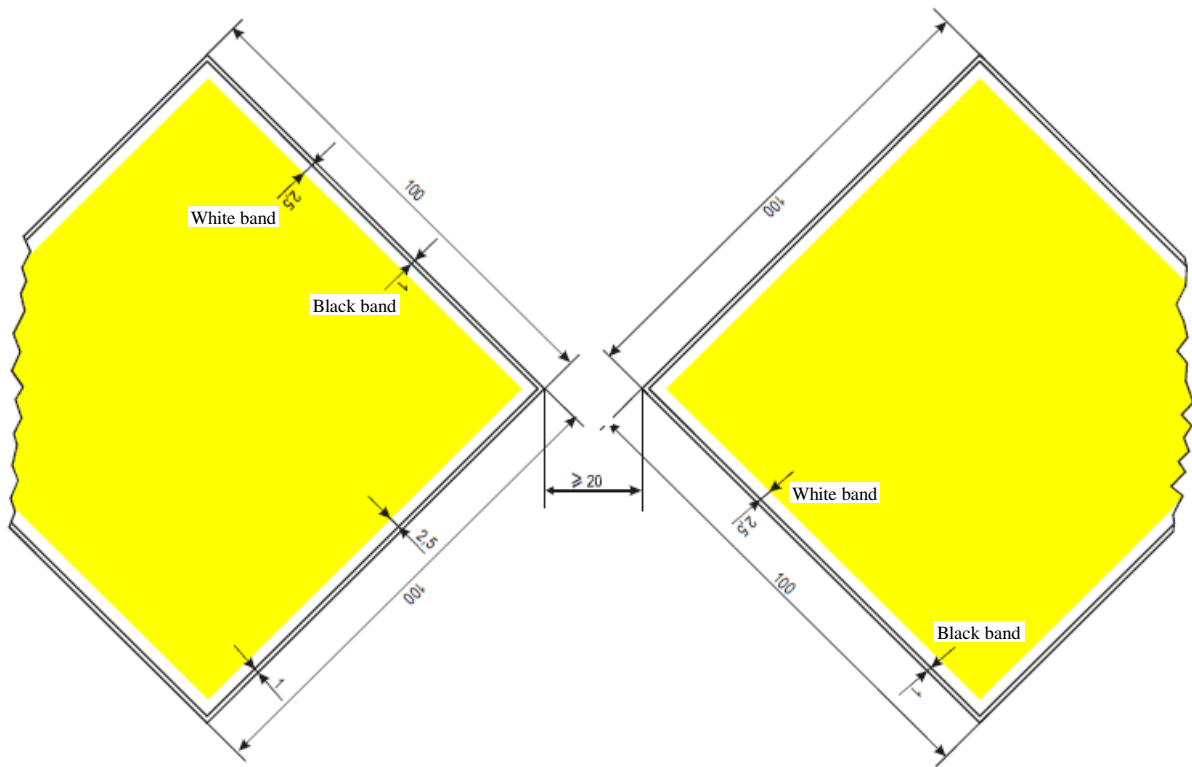

### D.1d

(Recommended fairway (Only in the direction indicated (passage in the opposite direction prohibited))

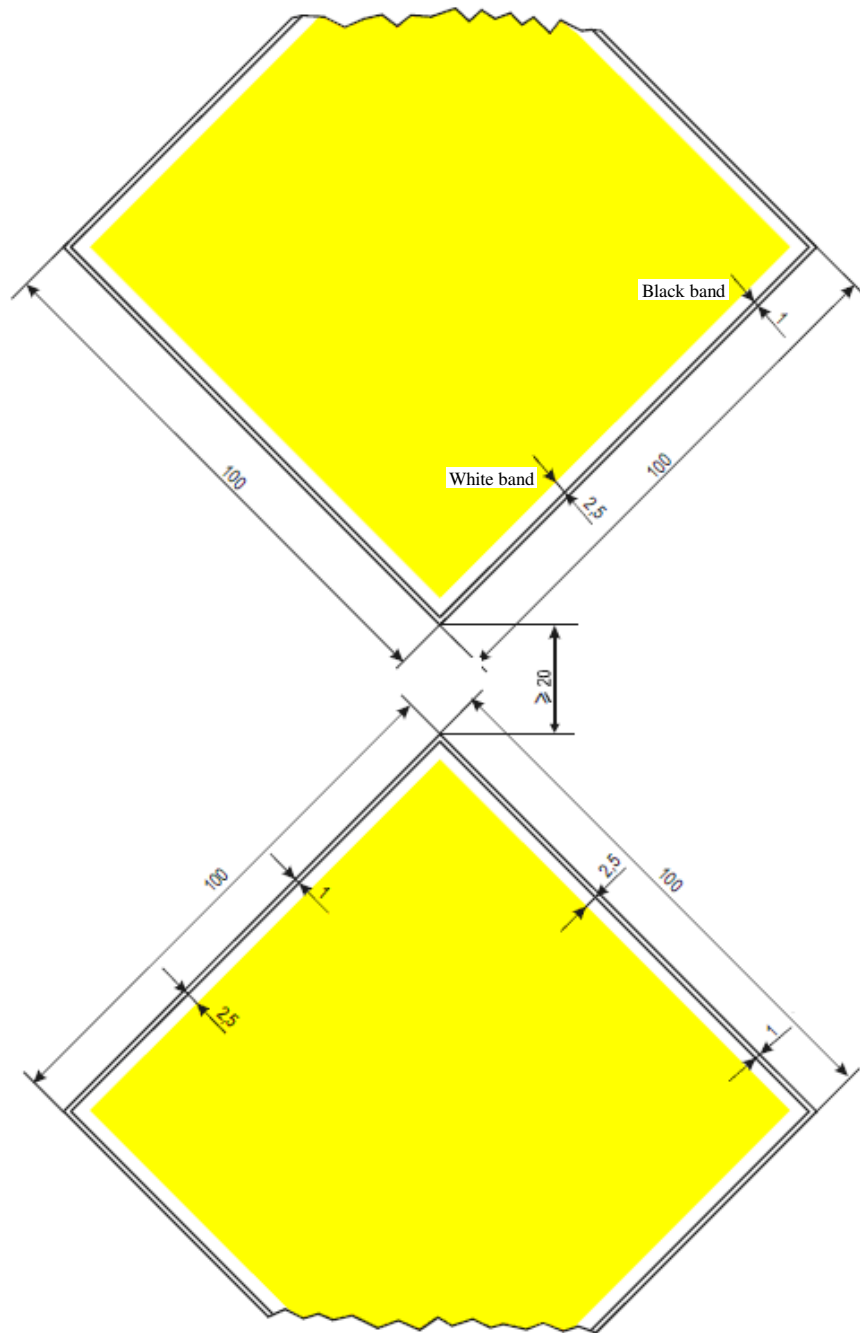

**D.2a**

(You are recommended to keep within the area indicated (in openings of bridges and weirs))

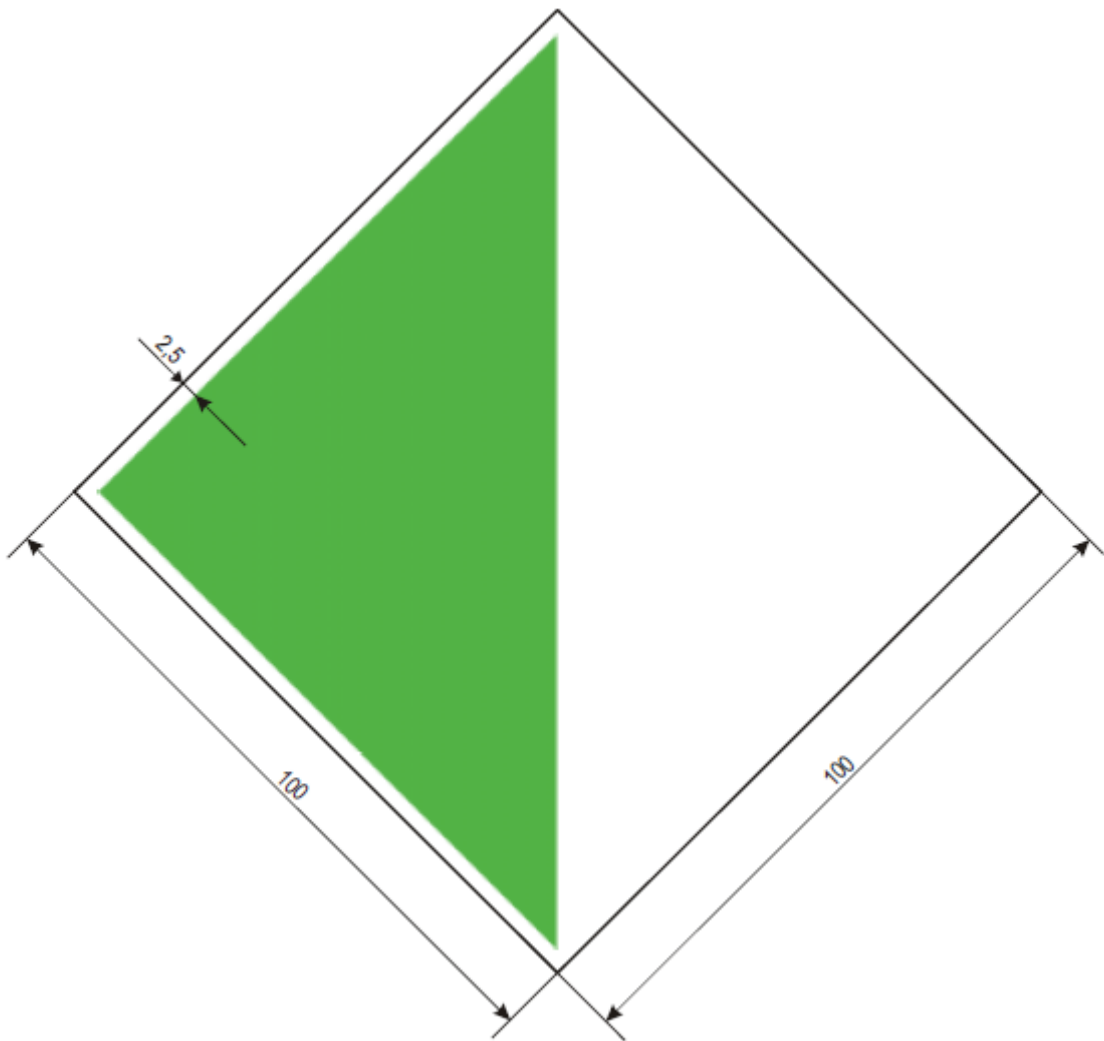

### D.3a

(You are recommended to proceed in the direction shown by the arrow)

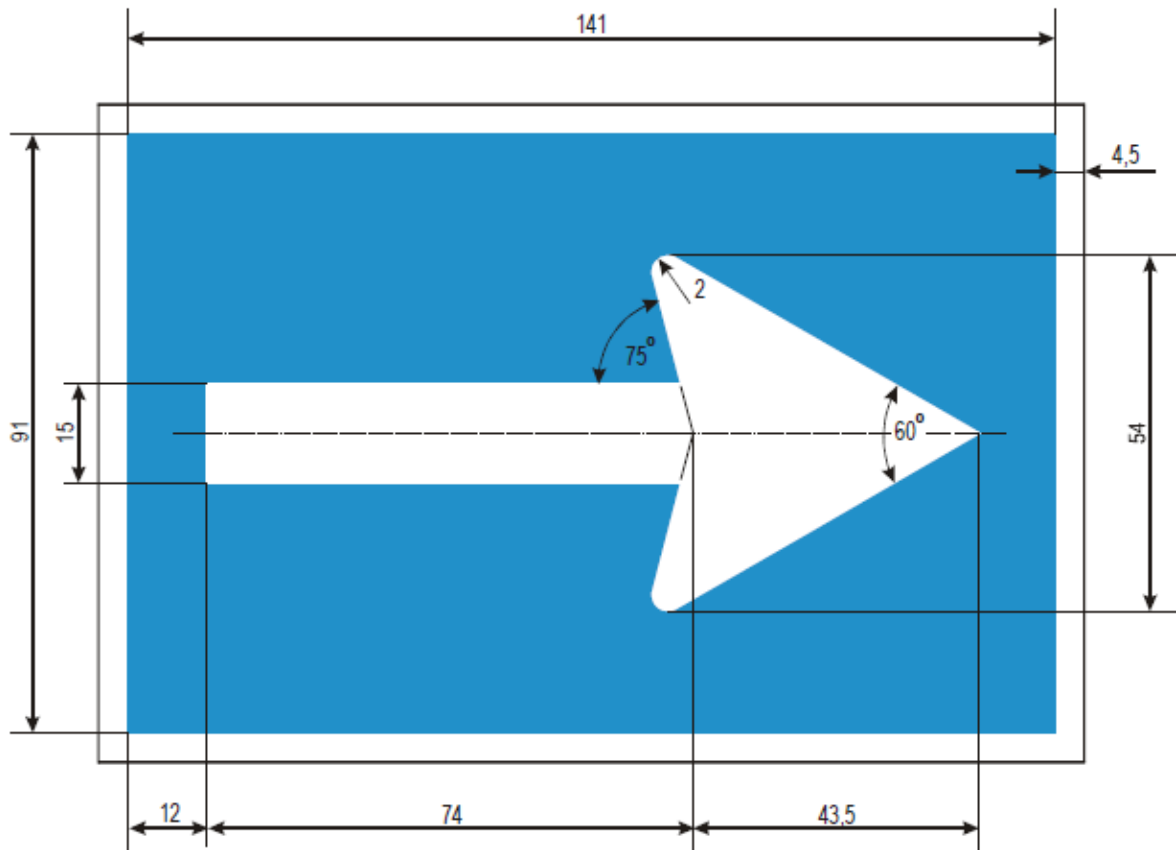

E. Informative signs

E.1

(Entry permitted (general sign))

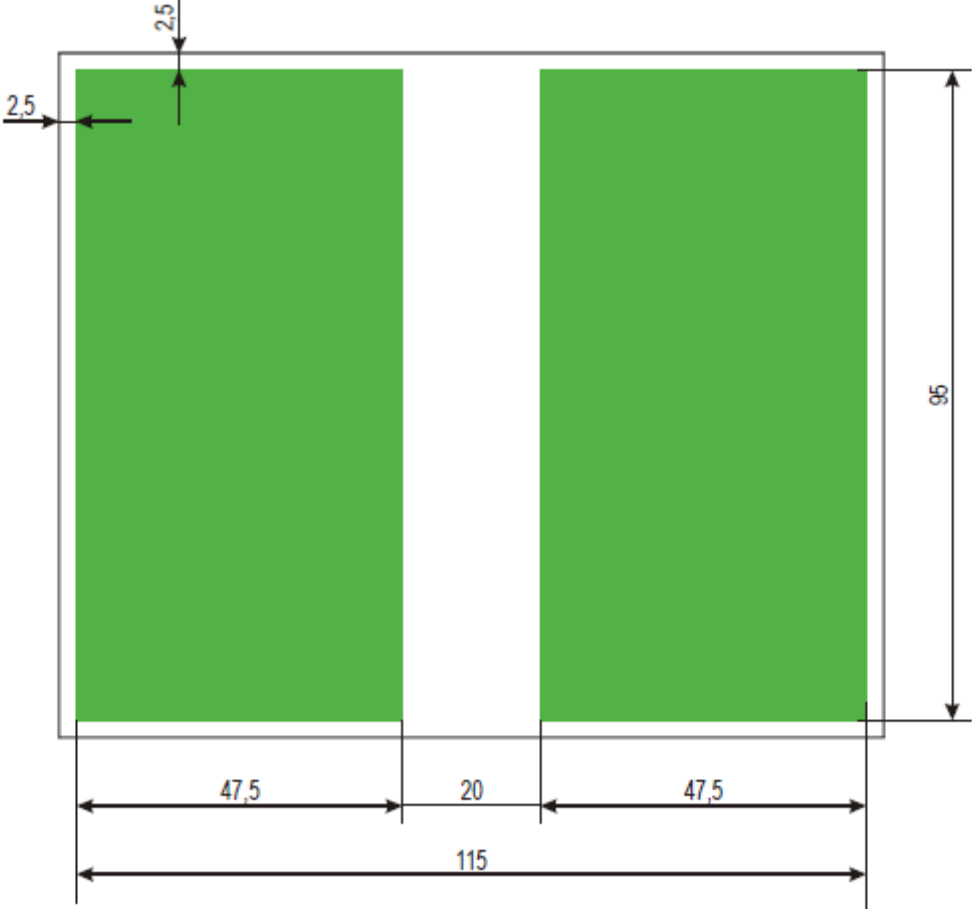

E.2

(Overhead cable crossing)

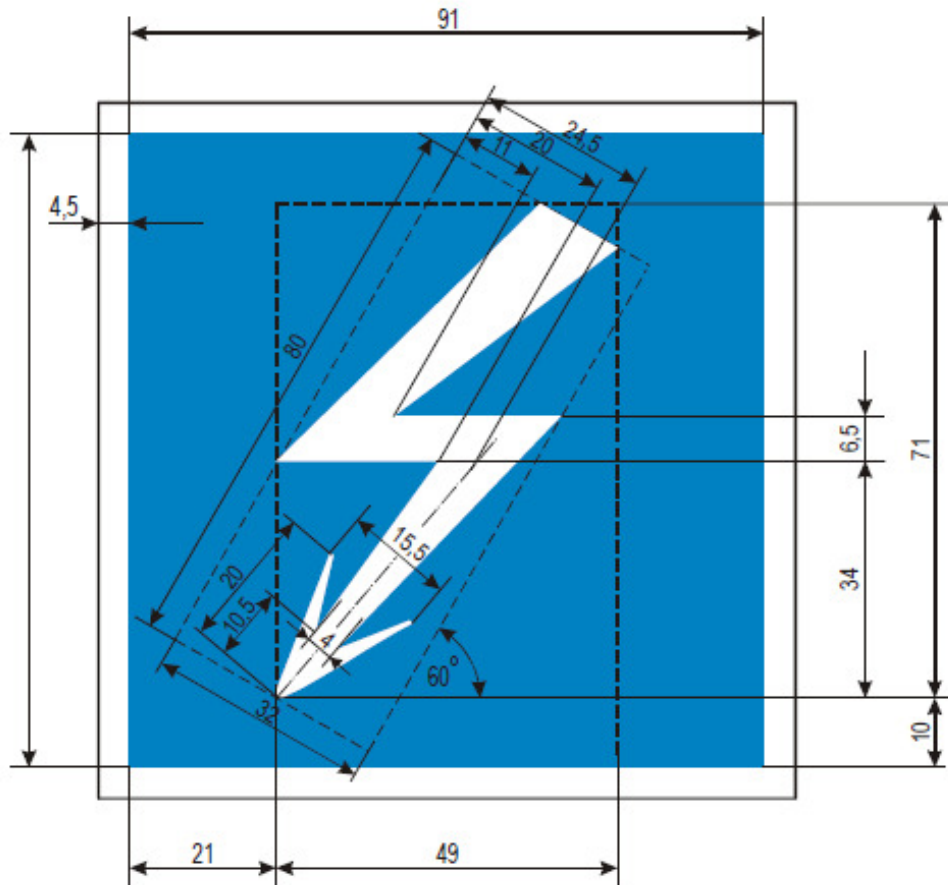

E.3

(Weir)

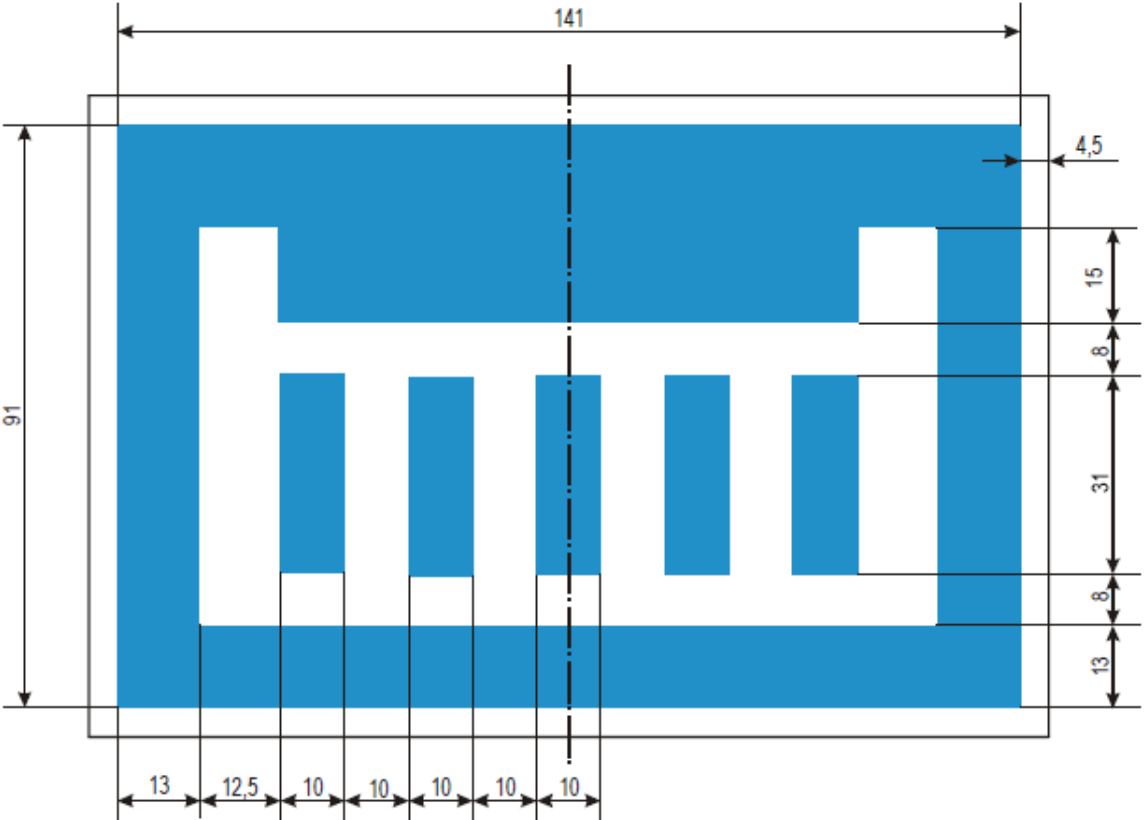



**E.4a**

(Ferry-boat not moving independently)

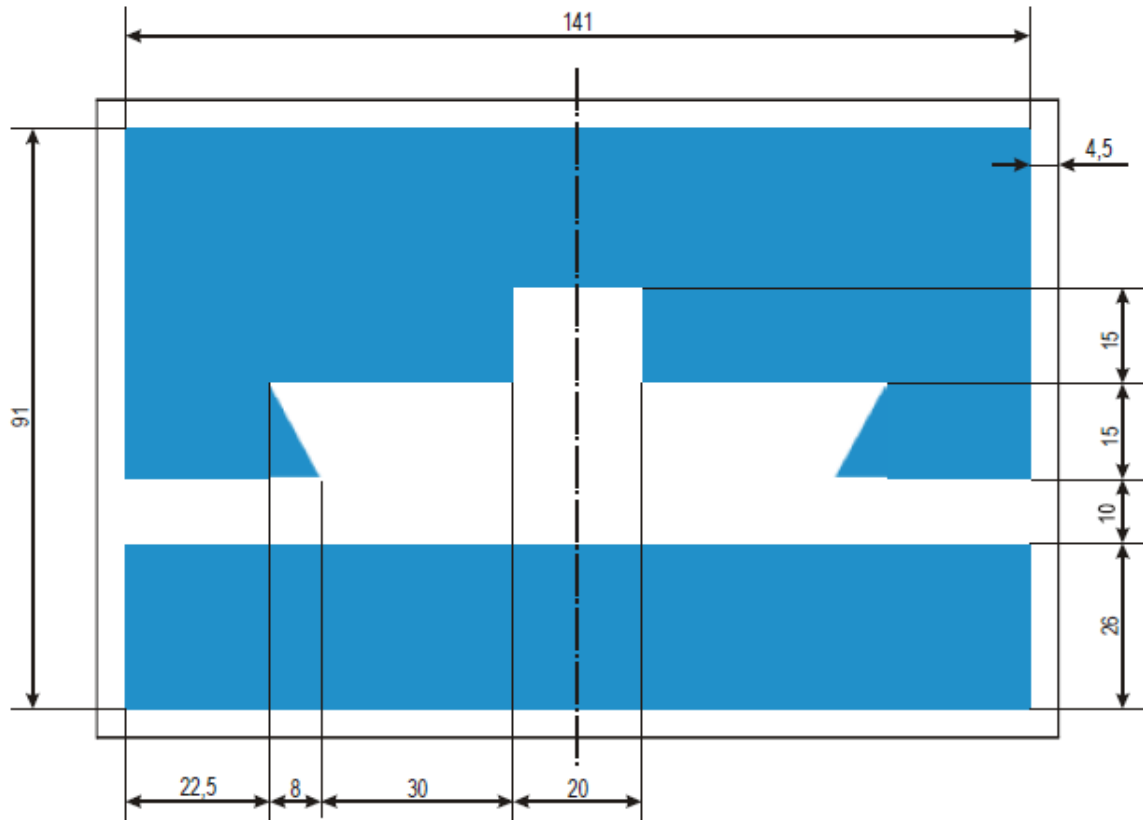

**E.4b**

(Ferry-boat moving independently)

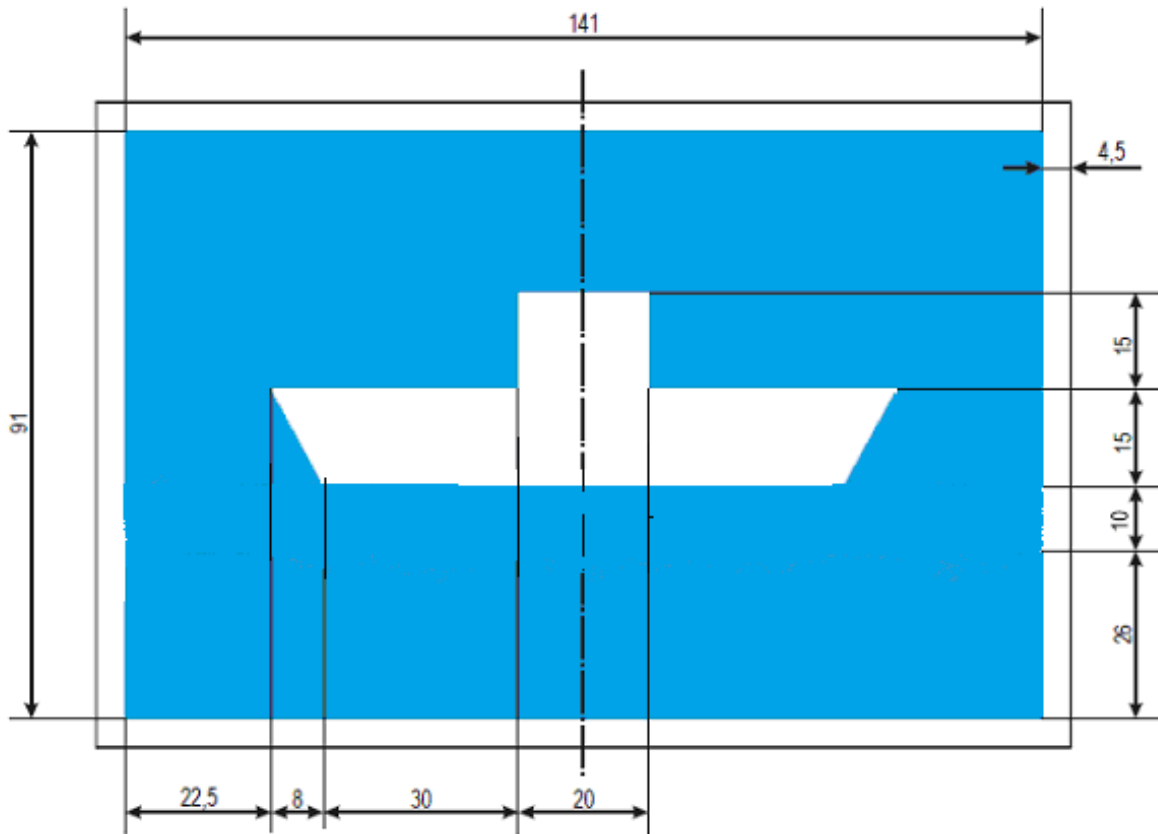

E.5

(Bearthing (i.e. anchoring or making fast to the bank) permitted)

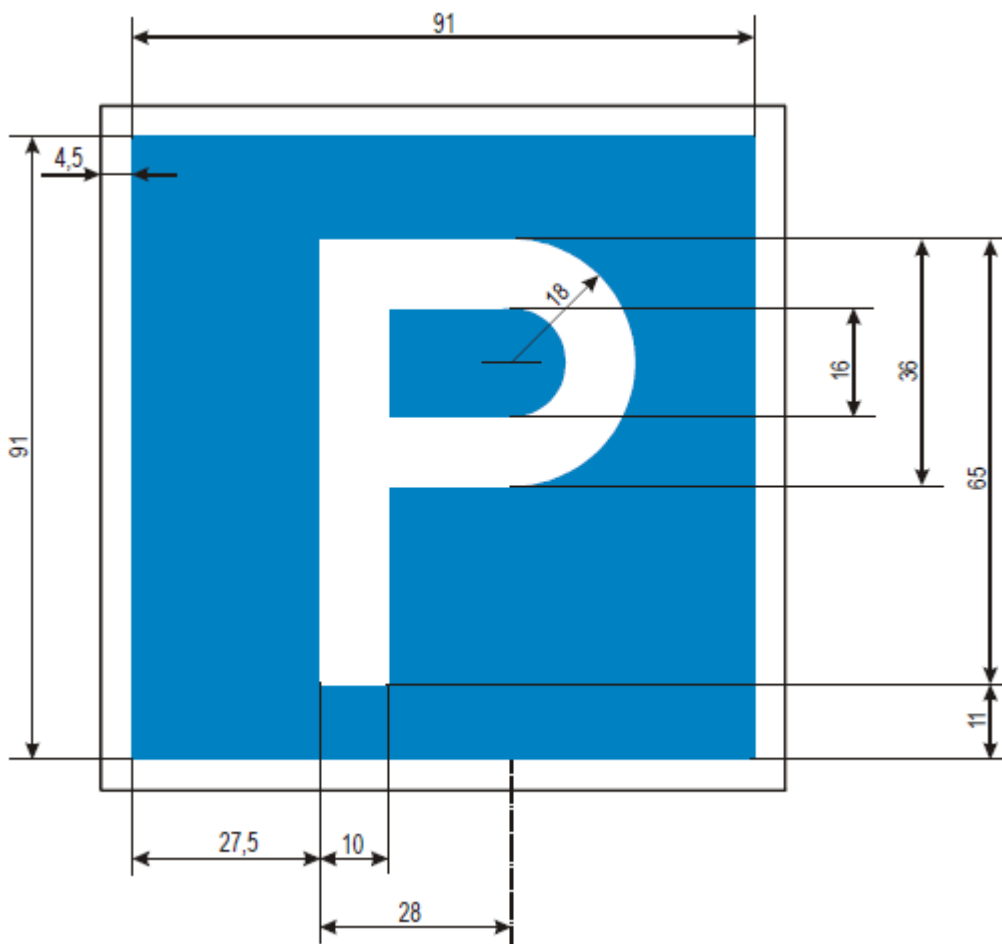

### E.5.1

(Berthing permitted on the stretch of water of the breadth measured from, and shown on the board in meters)

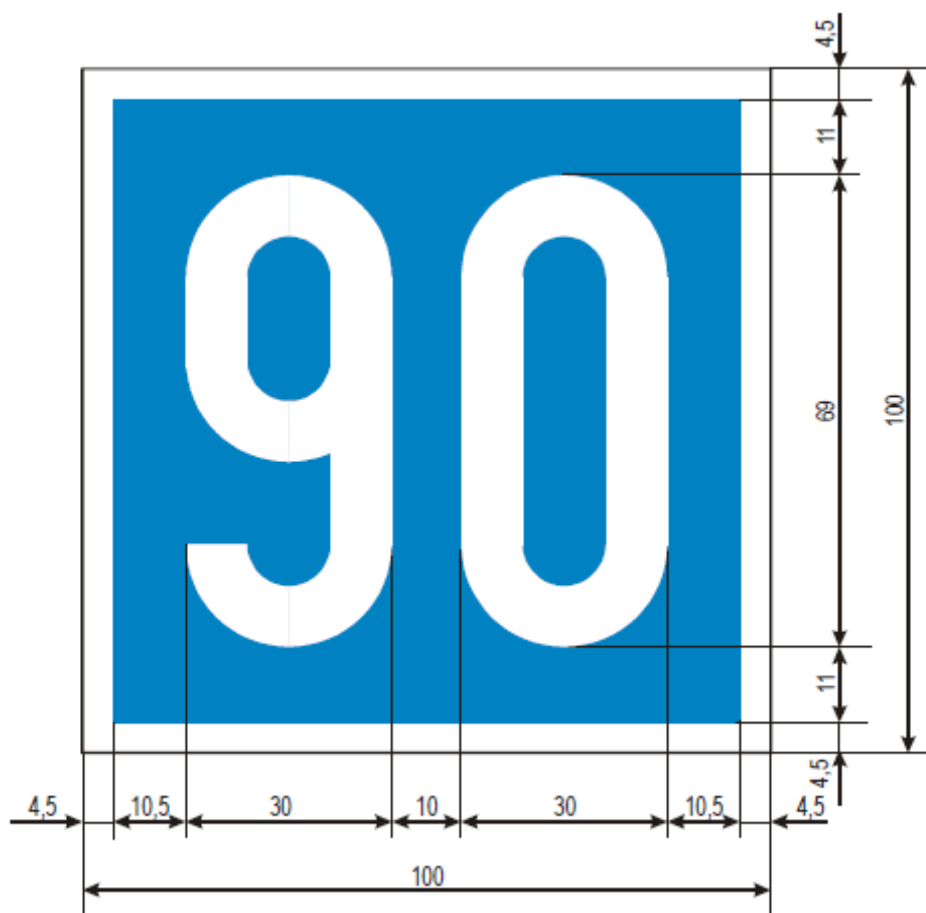

### E.5.2

(Berthing permitted on the stretch of the water bounded by the two distances measured from, and shown on the board in meters)

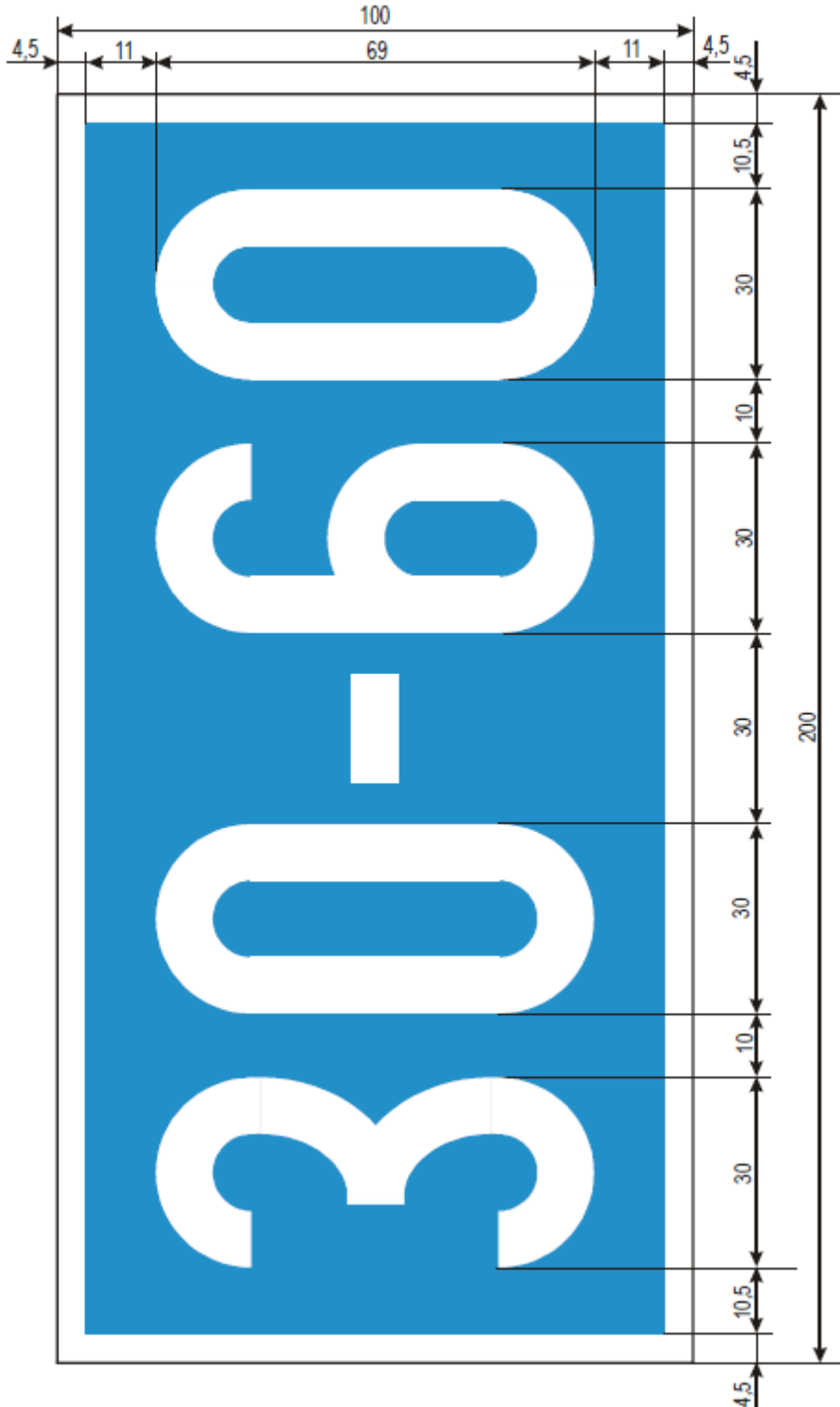

### E.5.3

(Maximum number of vessels permitted to berth abreast)

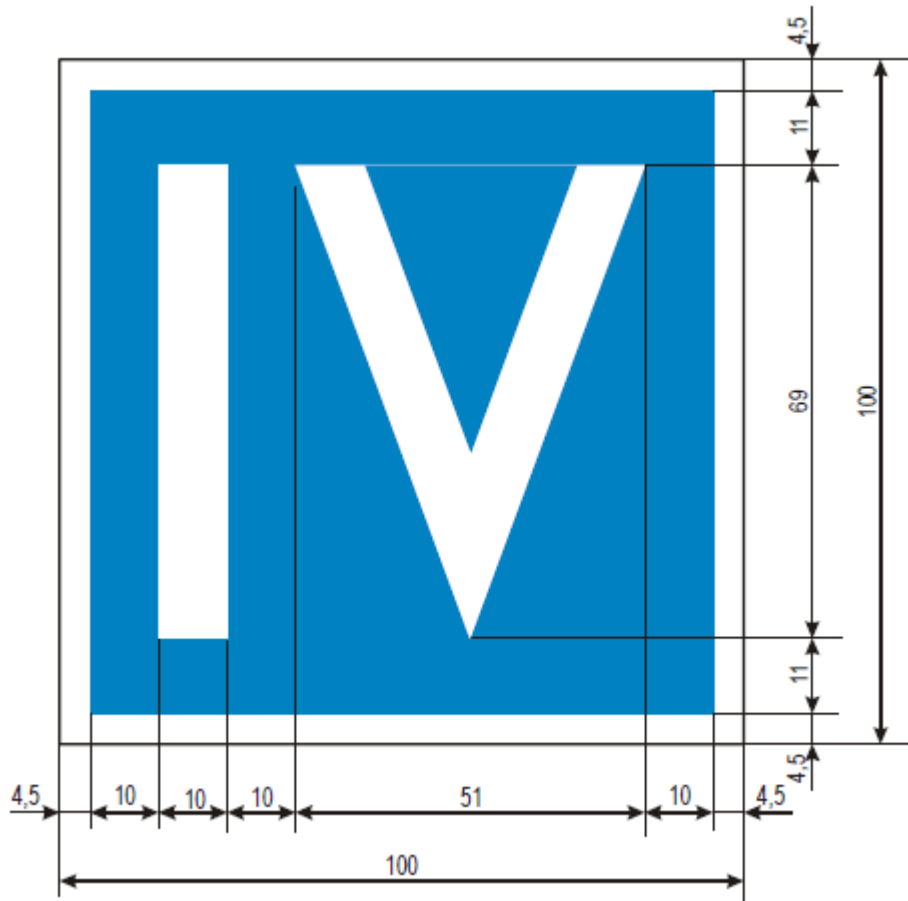

### E.5.4

(Berthing area reserved for pushing-navigation vessels that are not required to carry the marking)

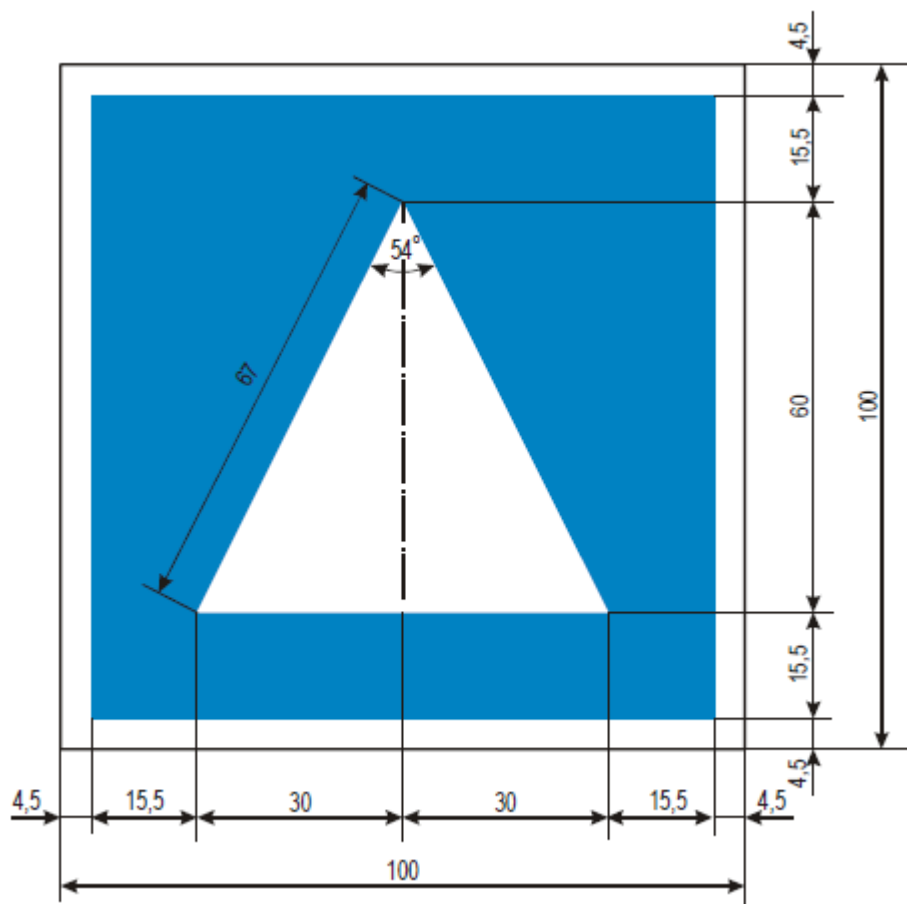

### E.5.5

(Berthing area reserved for pushing-navigation vessels that are required to carry one blue light or one blue cone)

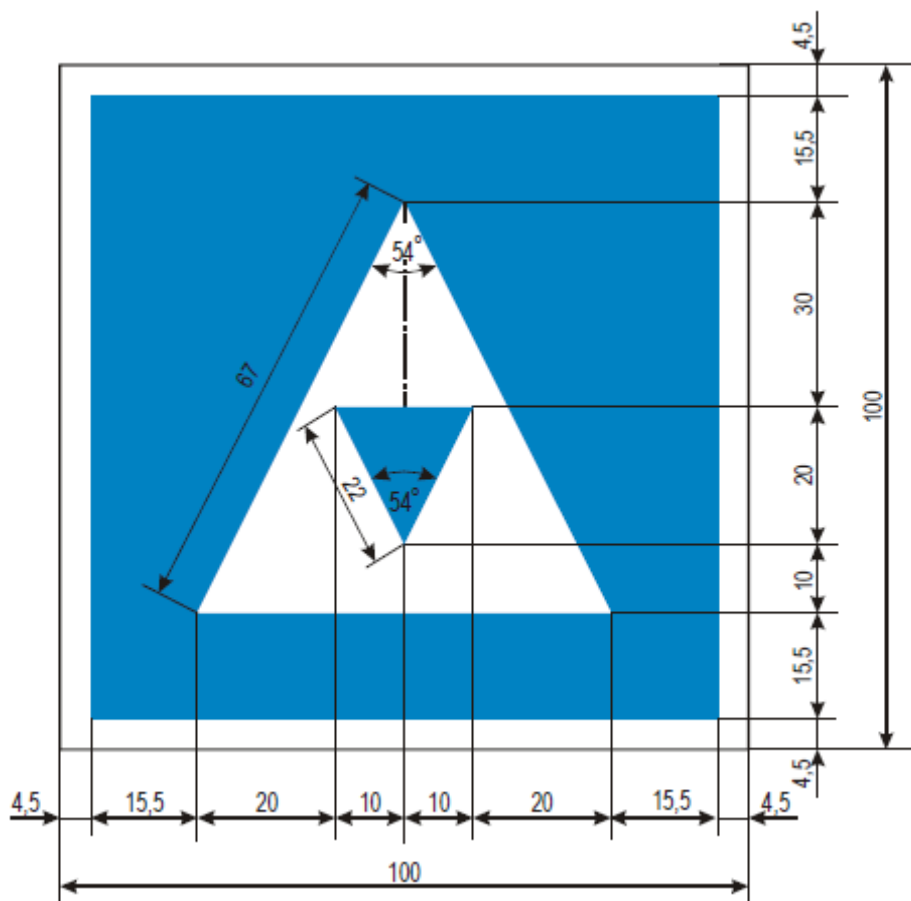



### E.5.6

(Berthing area reserved for pushing-navigation vessels that are required to carry two blue lights or two blue cones)

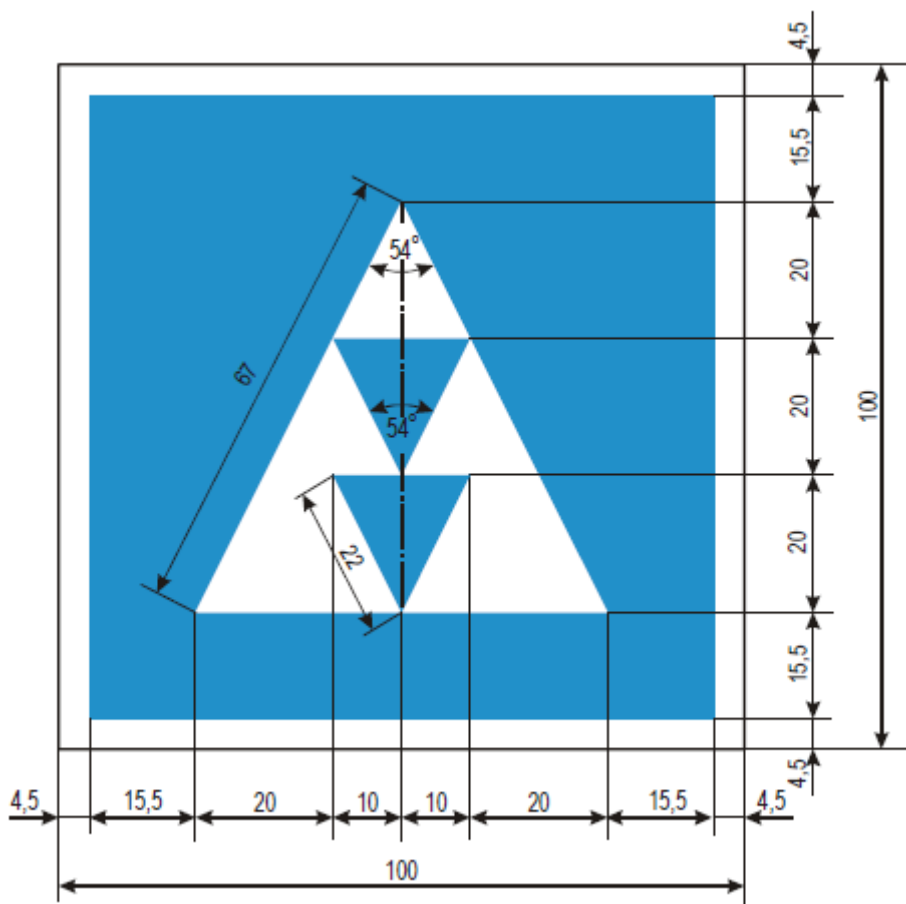

**E.5.7**

(Berthing area reserved for pushing-navigation vessels that are required to carry three blue lights or three blue cones)

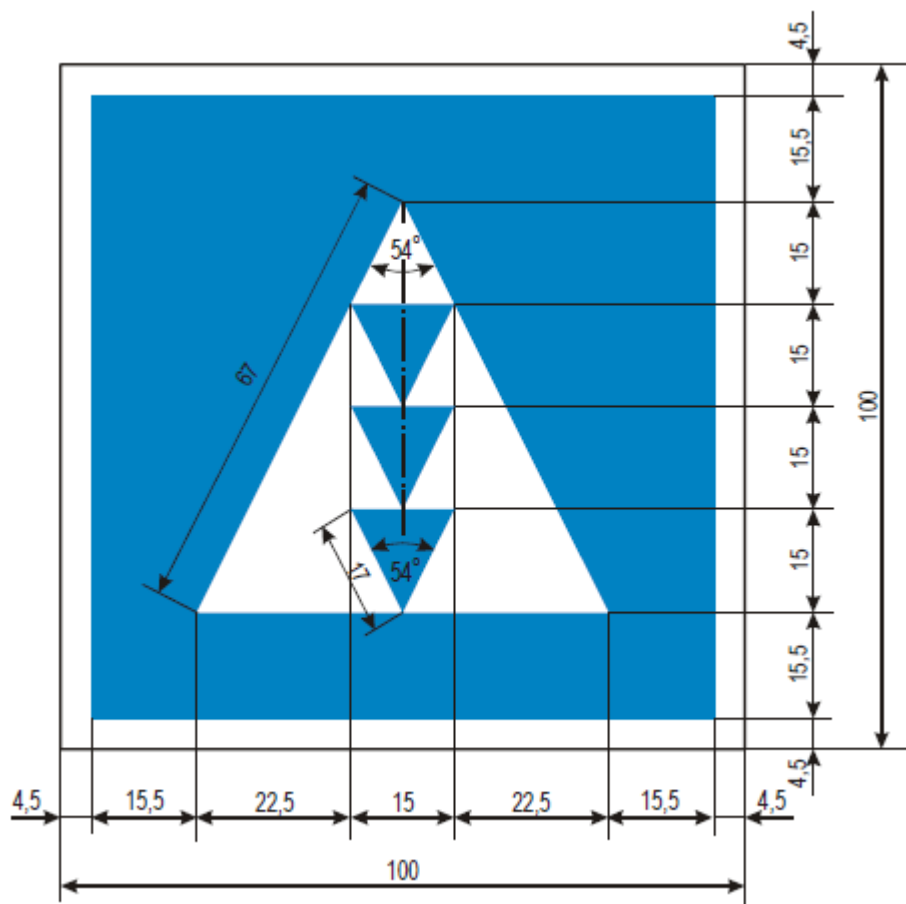

### E.5.8

(Berthing area reserved for vessels other than pushing-navigation vessels that are not required to carry the marking prescribed by the Navigation Rules in the Sava River Basin)

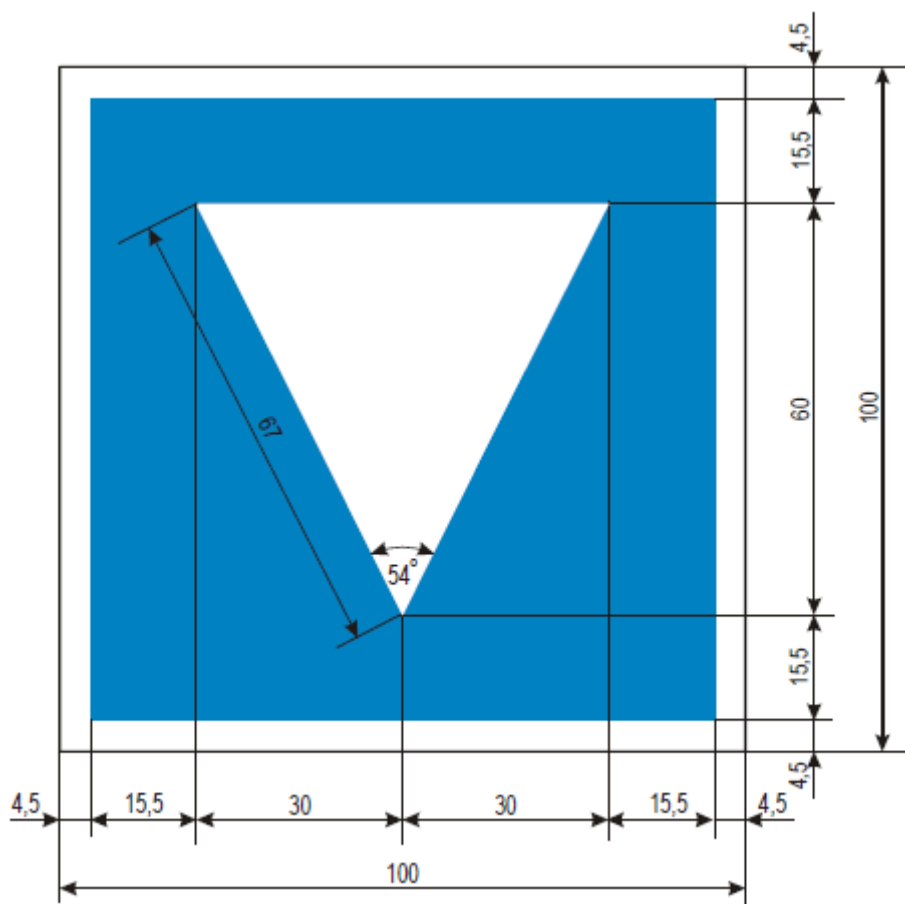

### E.5.9

(Berthing area reserved for vessels other than pushing-navigation vessels that are required to carry one blue light or one blue cone)

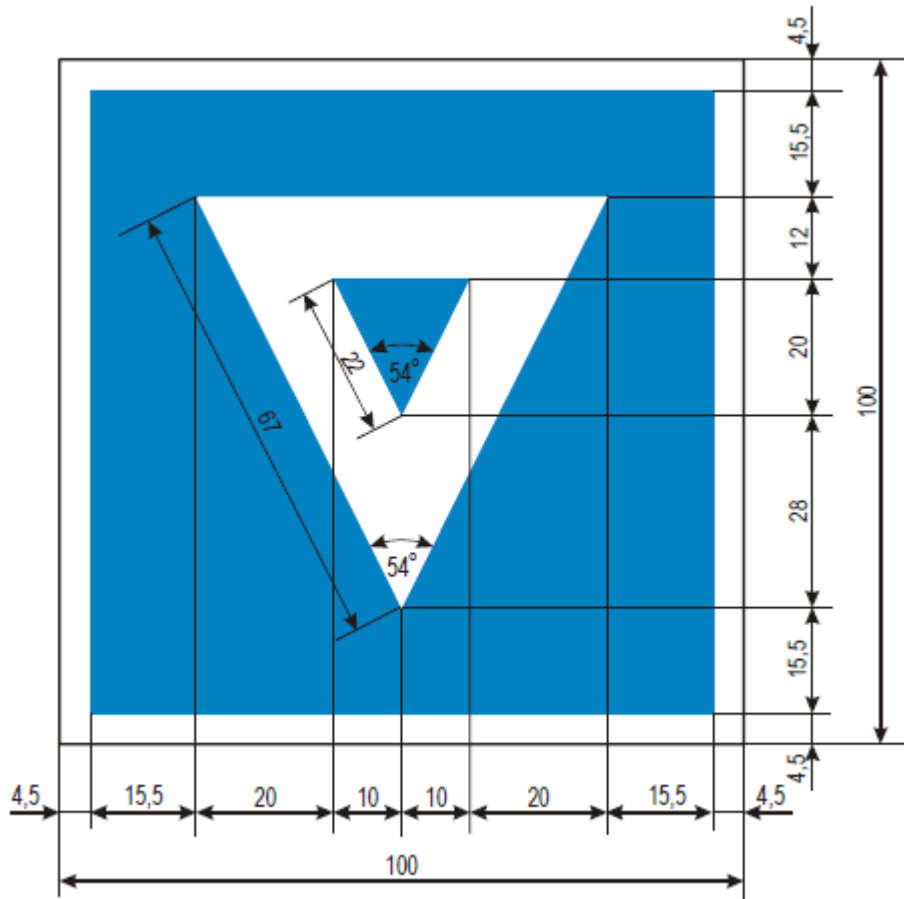

### E.5.10

(Berthing area reserved for vessels other than pushing-navigation vessels that are required to carry two blue lights or two blue cones)

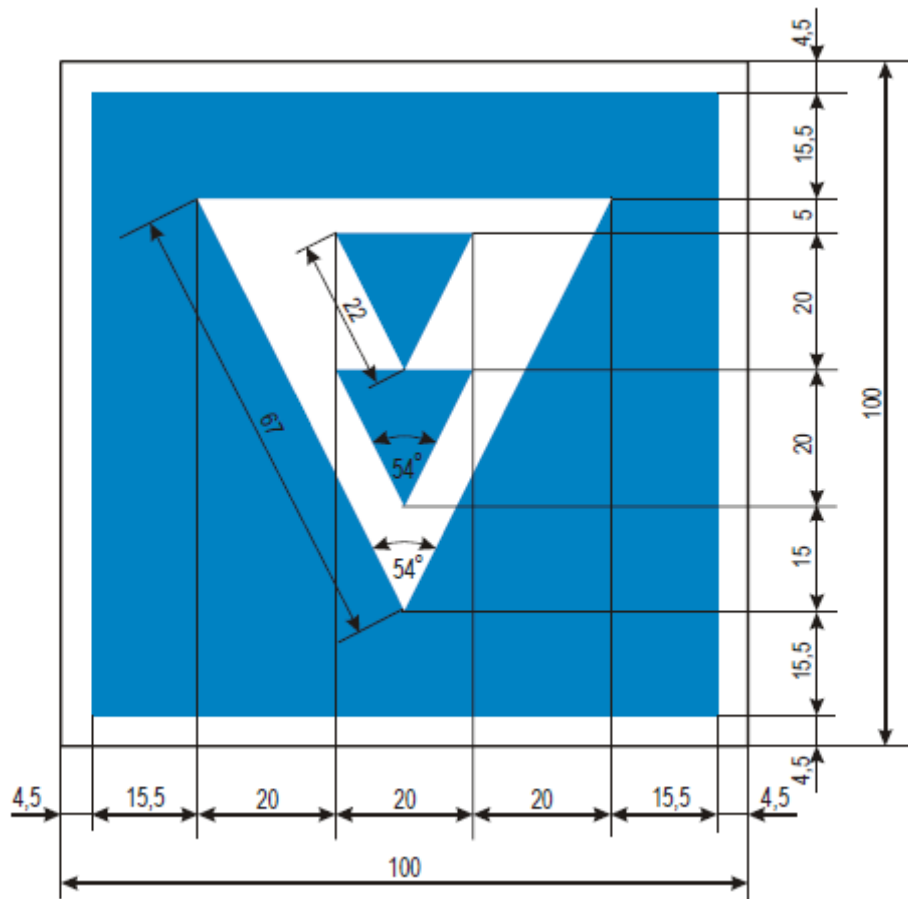

### E.5.11

(Berthing area reserved for vessels other than pushing-navigation vessels that are required to carry three blue lights or three blue cones)

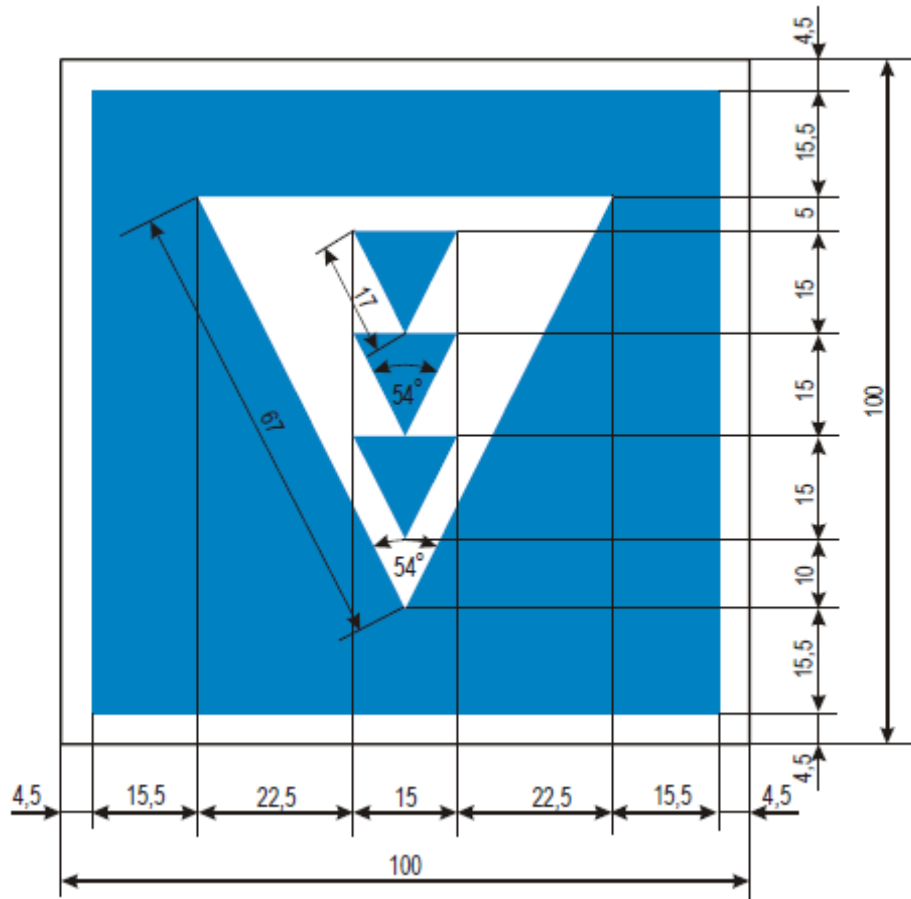

**E.5.12**

(Berthing area reserved for all vessels that are not required to carry the marking)

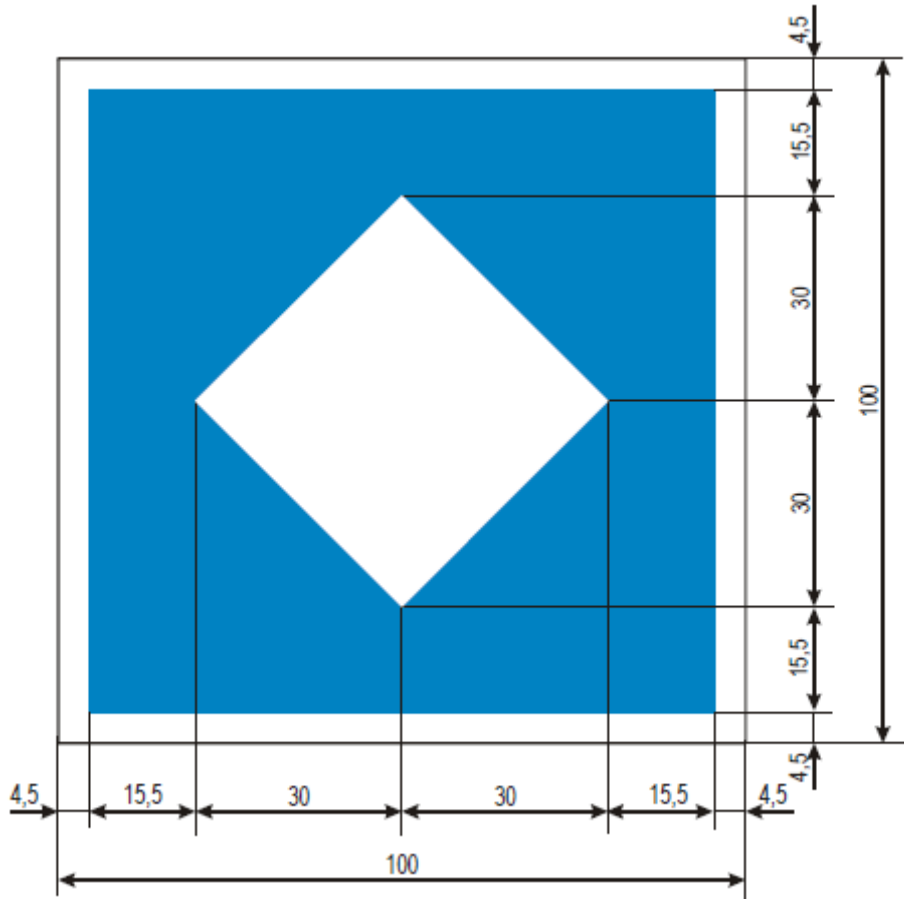

### E.5.13

(Berthing area reserved for all vessels that are required to carry one blue light or one blue cone)

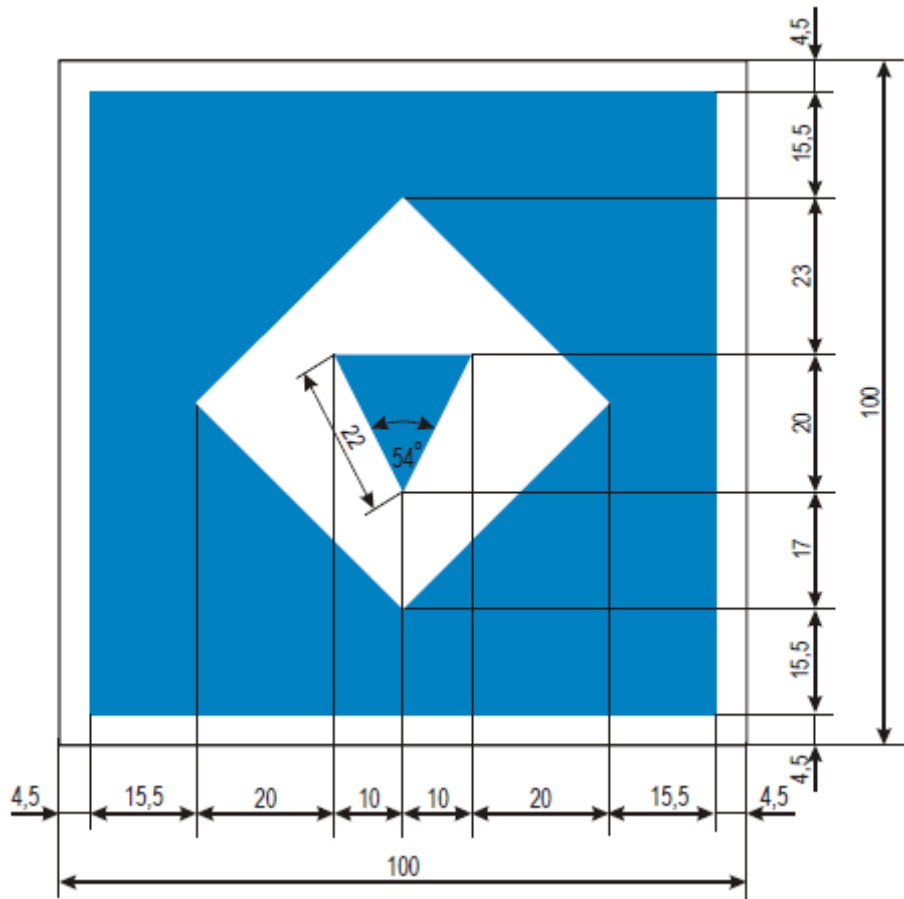



### E.5.14

(Berthing area reserved for all vessels that are required to carry two blue lights or two blue cones)

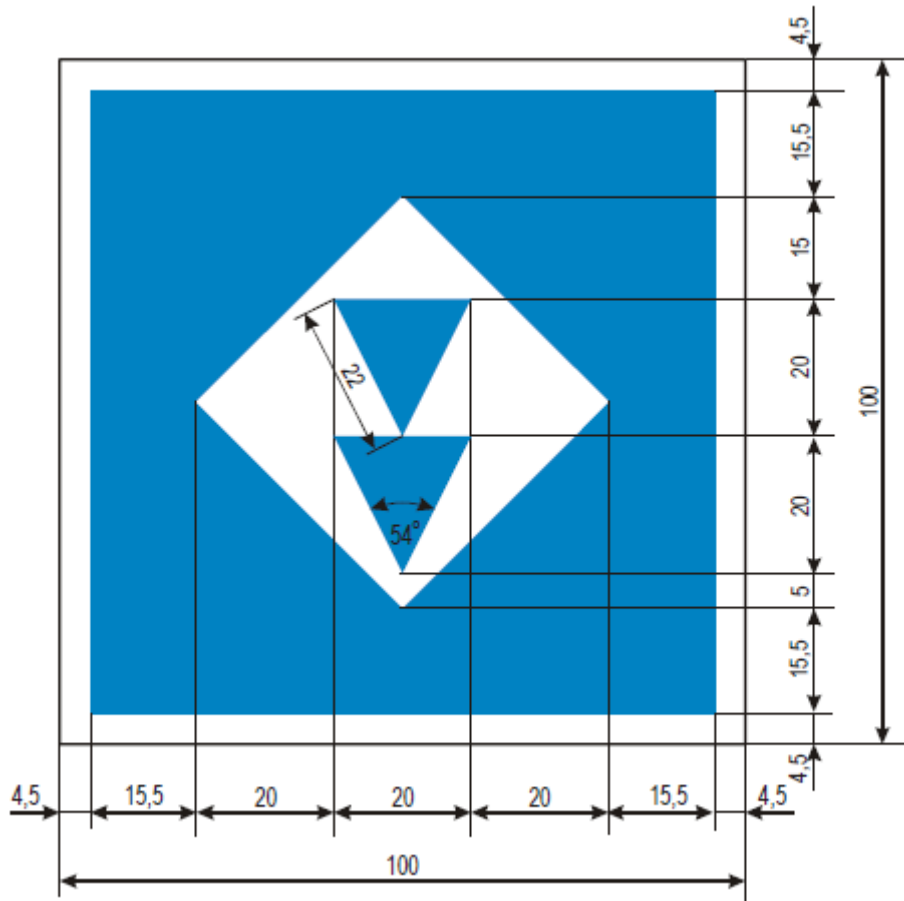

**E.5.15**

(Berthing area reserved for all vessels that are required to carry three blue lights or three blue cones)

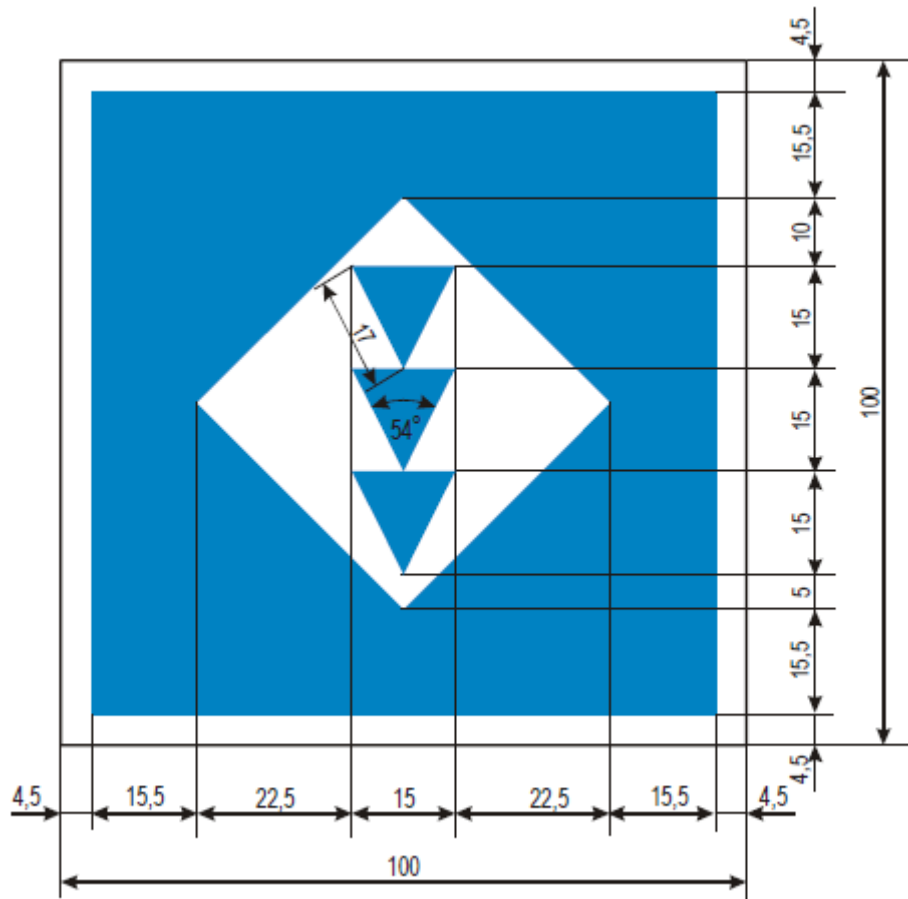

**E.6**

(Anchoring or trailing of anchors, cables or chains permitted)

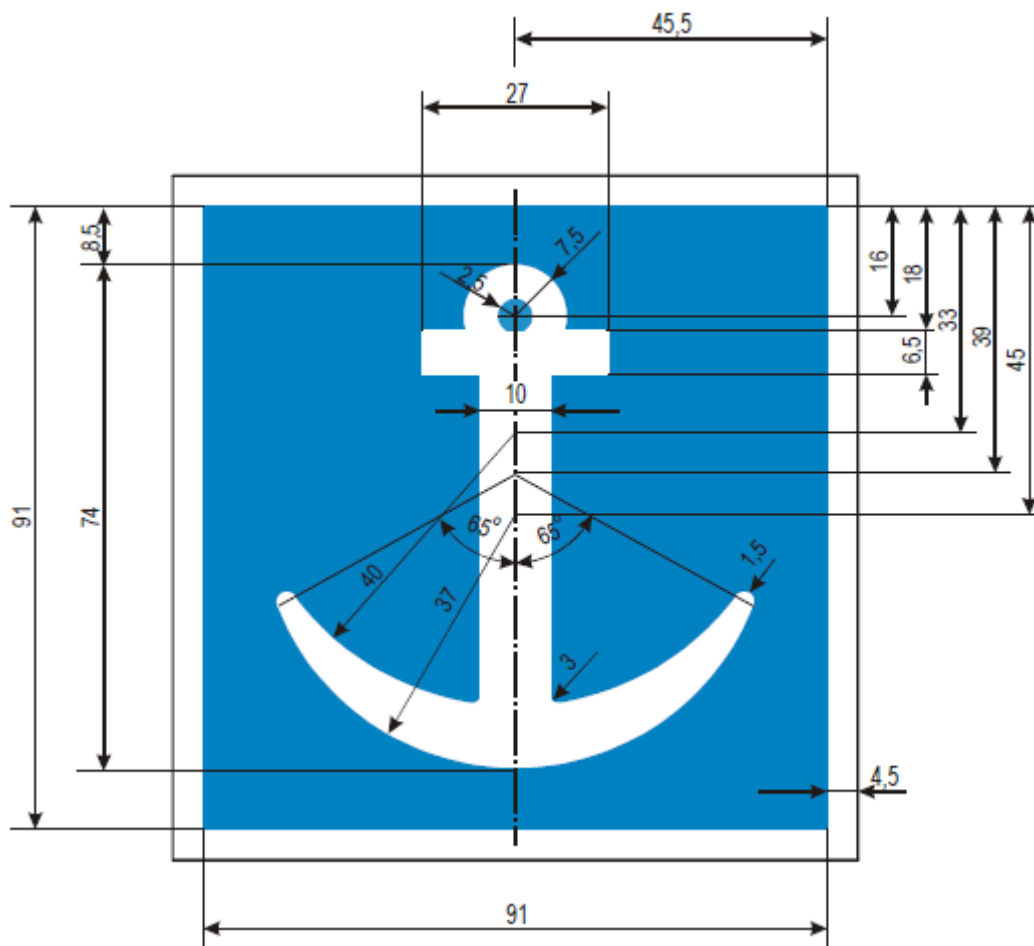

### E.6.1

(Use of spuds permitted ermitted)

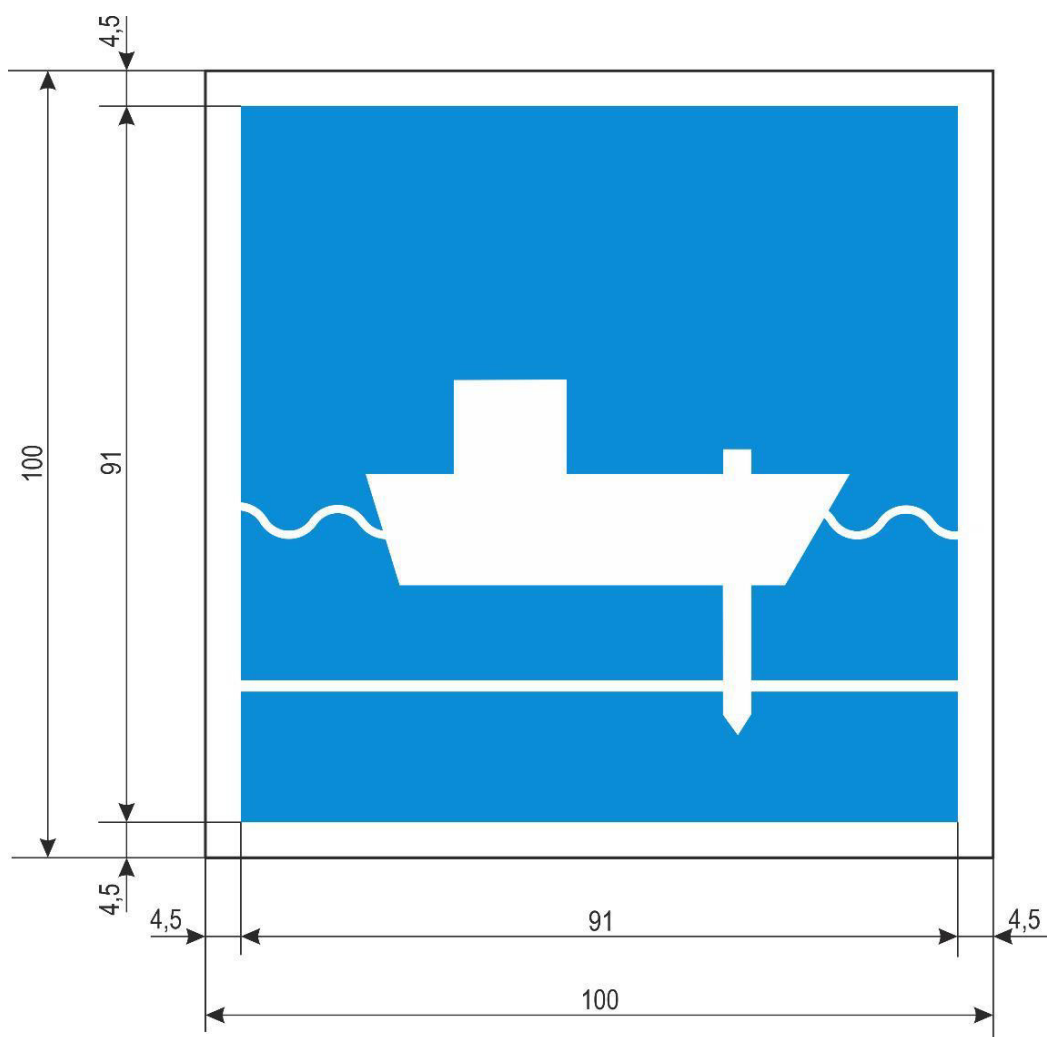

E.7

(Making fast to the bank permitted)

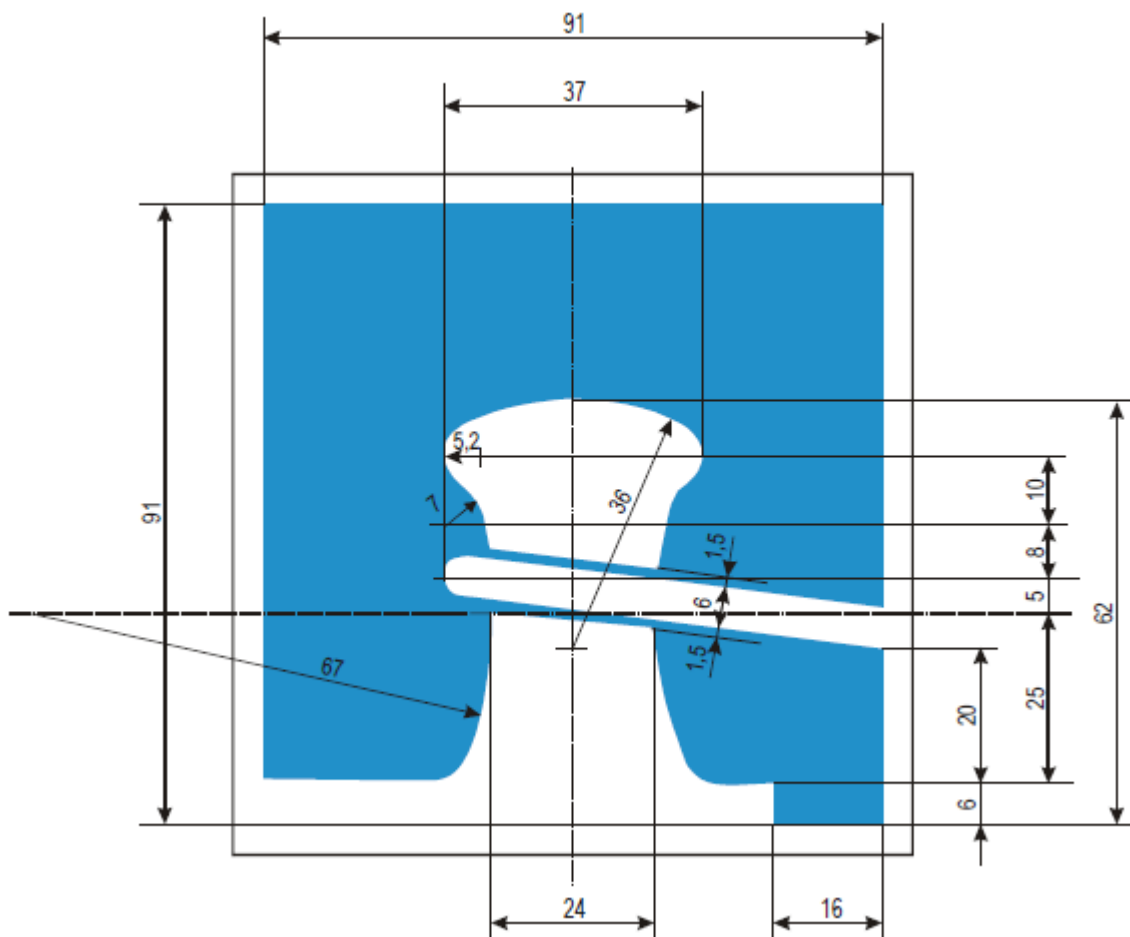

### E.7.1

(Berthing area reserved for loading and unloading vehicles. (Maximum duration of berthing permitted may be added on an information plate below the board))

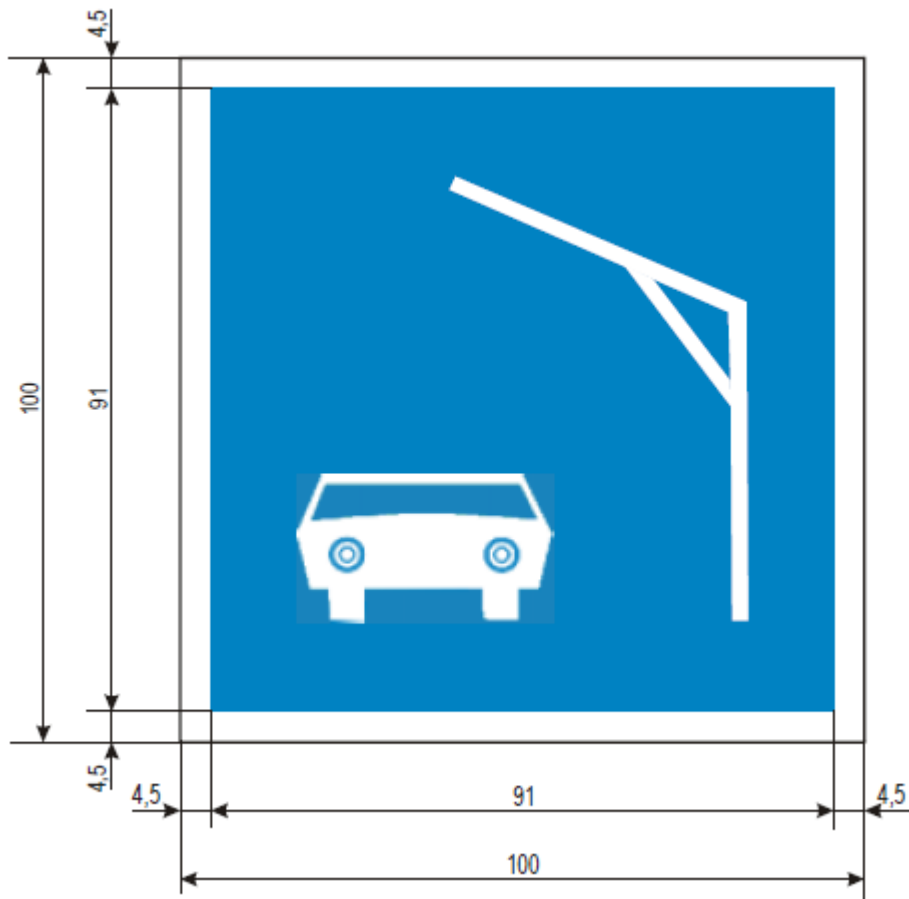

E.8

(Turning area)

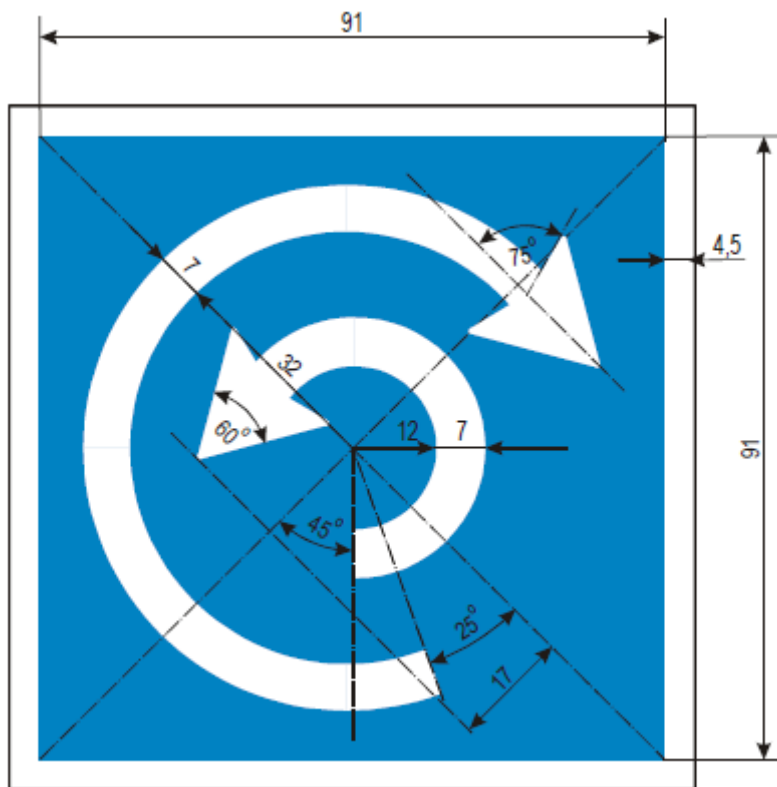

**E.9a**

(The waterways being approached are considered to be tributaries of the waterway)

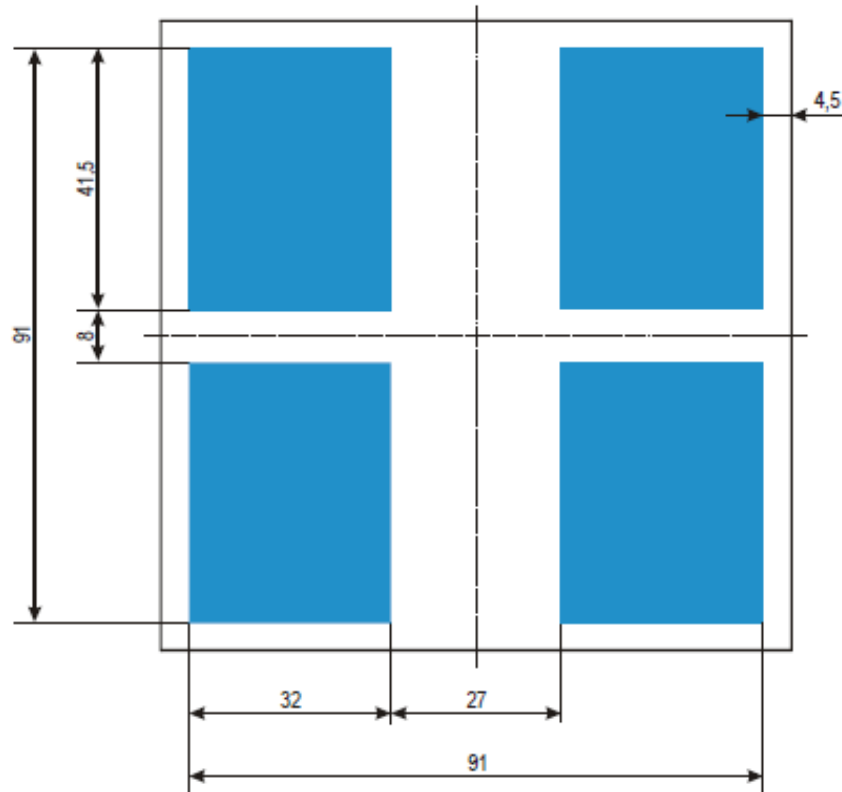



**E.9b**

(The waterways being approached are considered to be tributaries of the waterway)

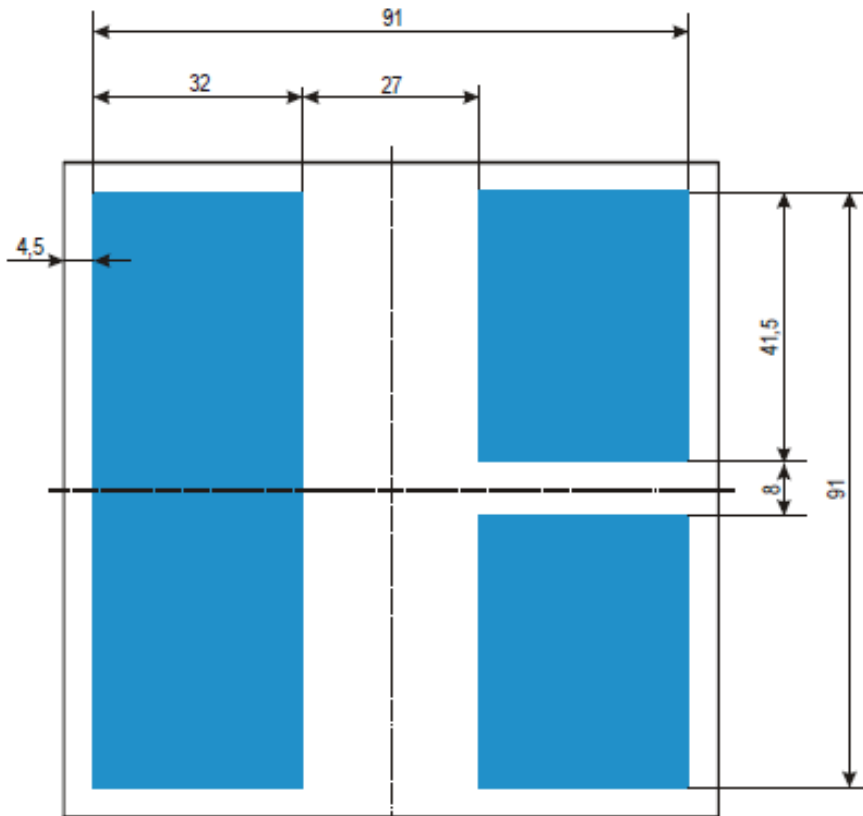

**E.9.c**

**(The waterways being approached are considered to be tributaries of this waterway)**

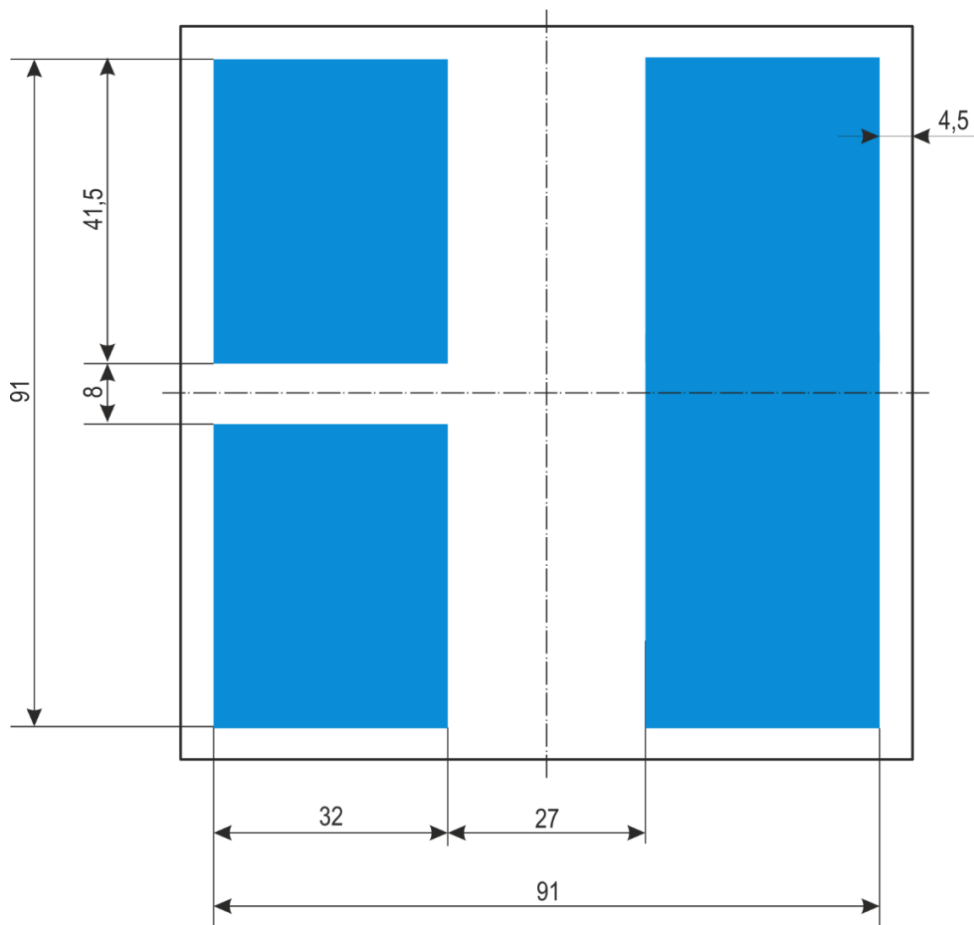

**E.10a**

(This waterway is considered to be a tributary of the waterway being approached)

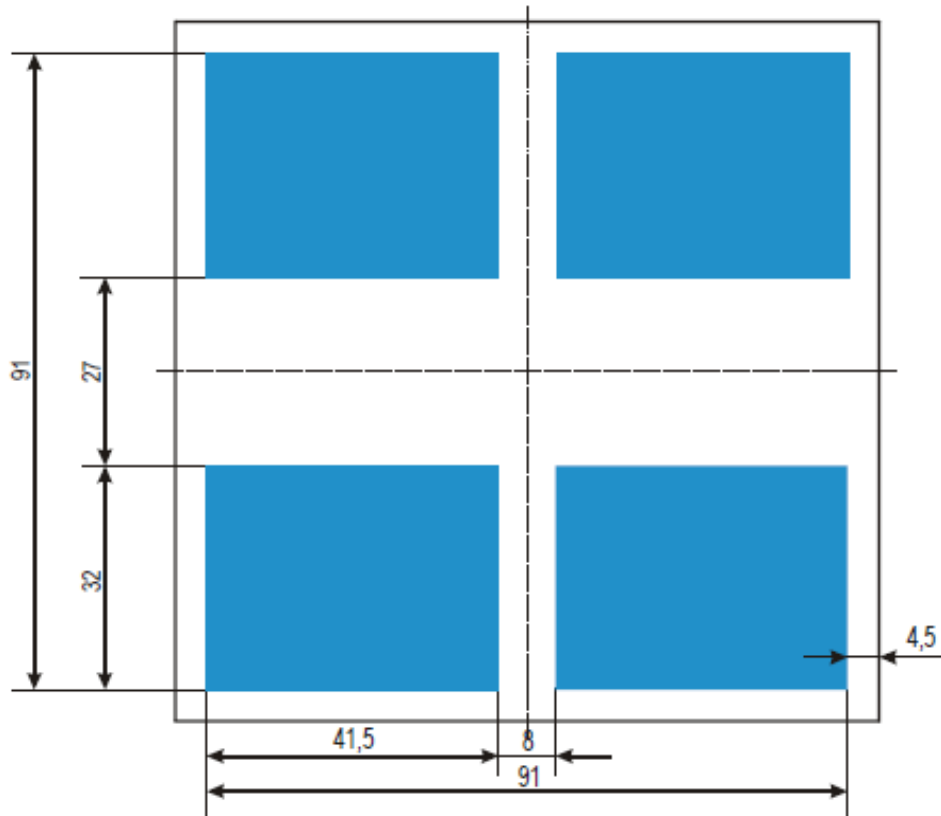

**E.10b**

(This waterway is considered to be a tributary of the waterway being approached)

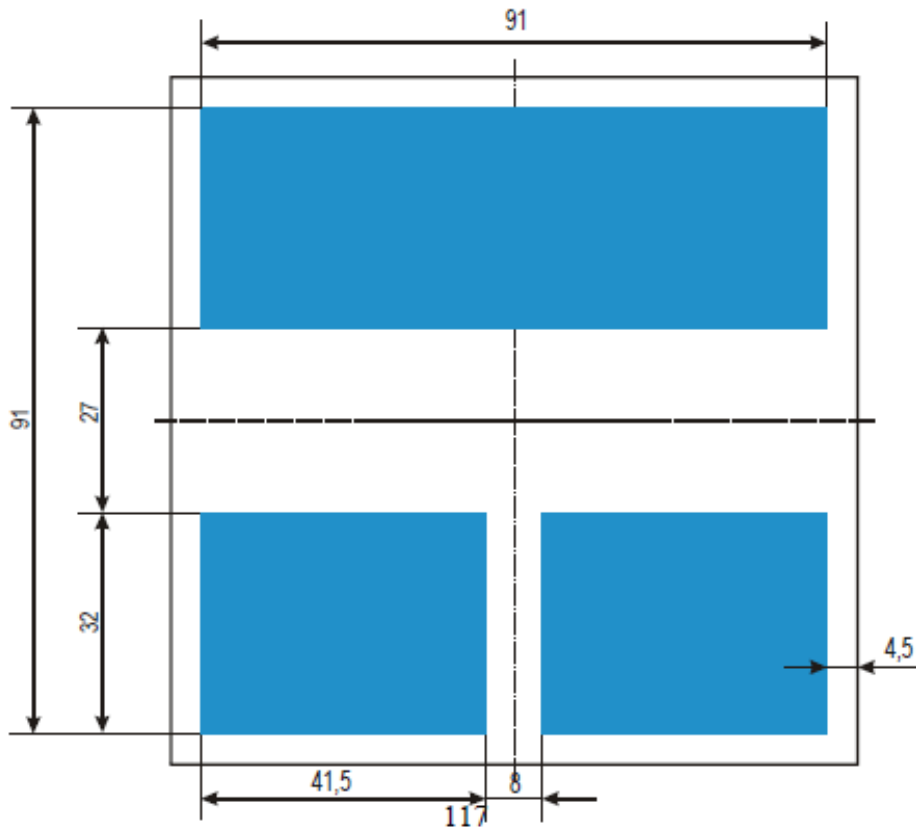

**E.11a**

(End of a prohibition or obligation applying to traffic in one direction only, or end of restriction)

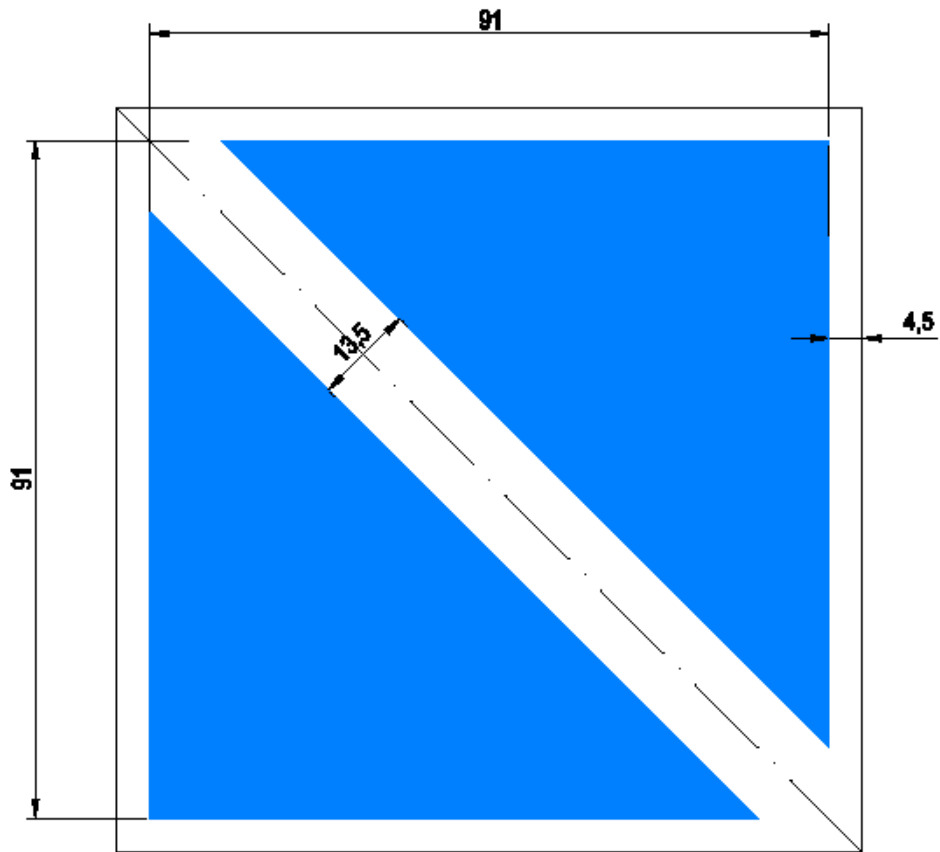

**E.11b**

(End of a prohibition or obligation applying to traffic in one direction only, or end of restriction)

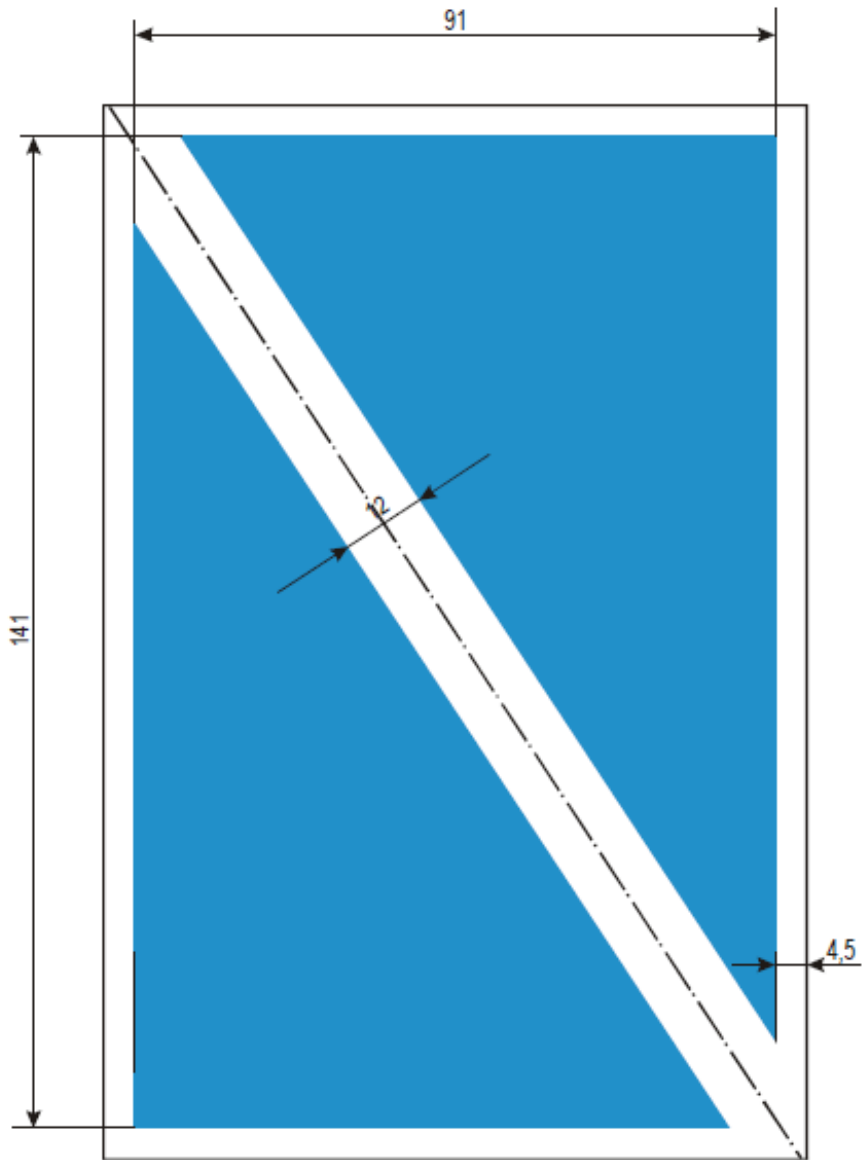

E.13

(Drinking water supply)

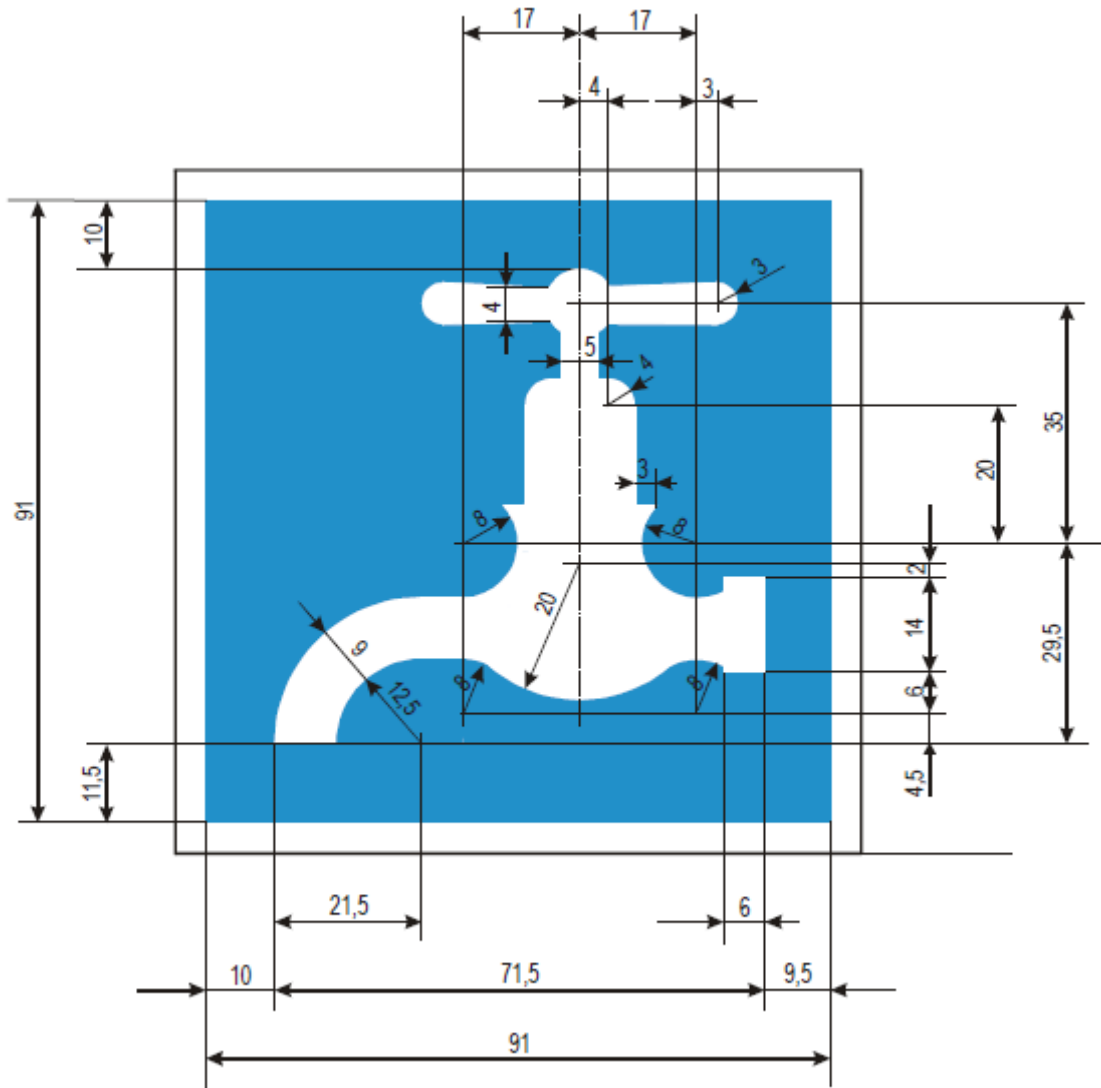

**E.14**

(Telephone)

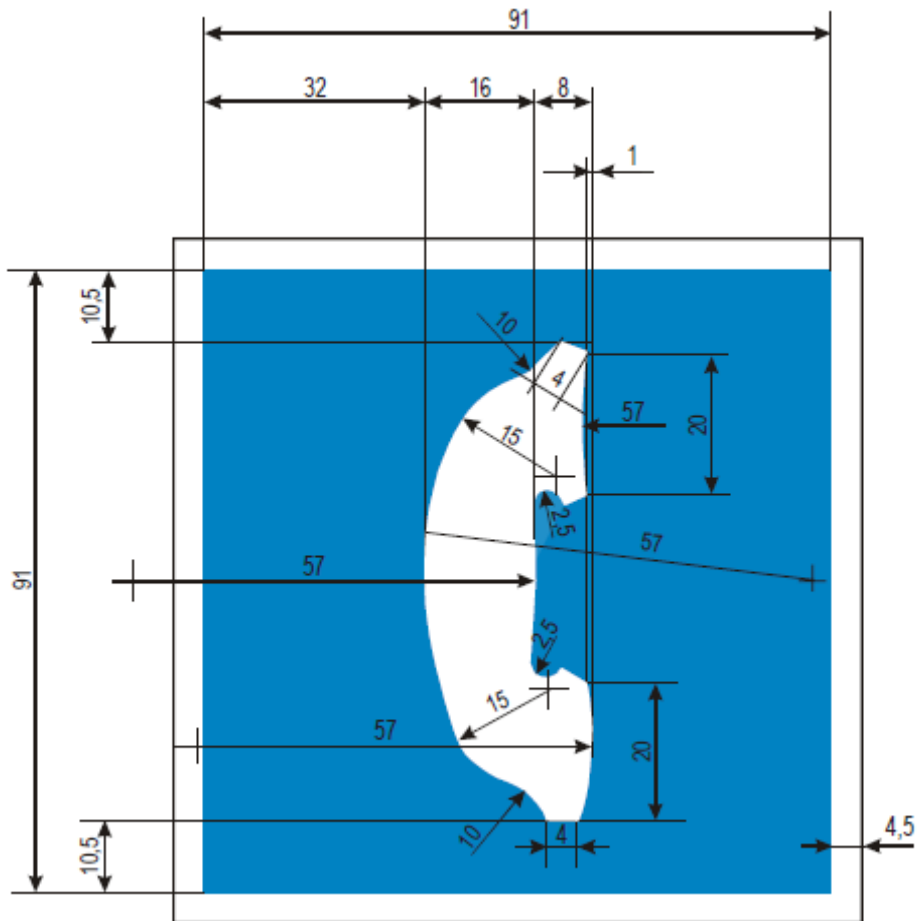



**E.15**

(Motorized vessels permitted)

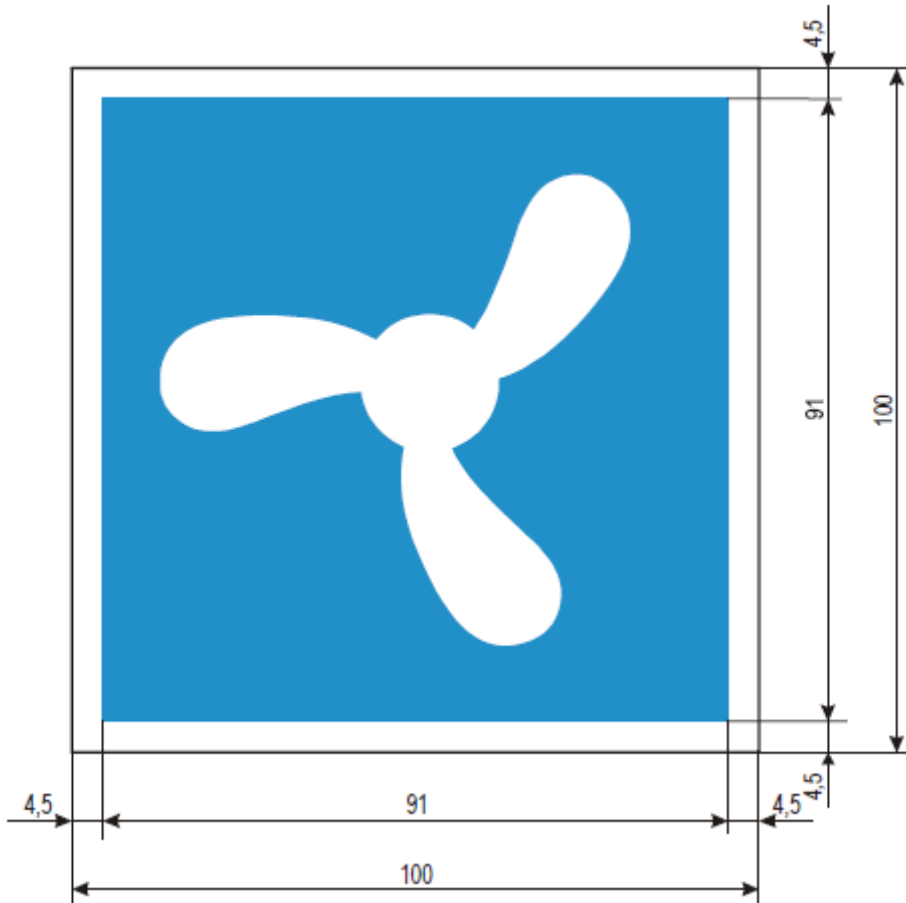

**E.16**

(Sports or pleasure craft permitted)

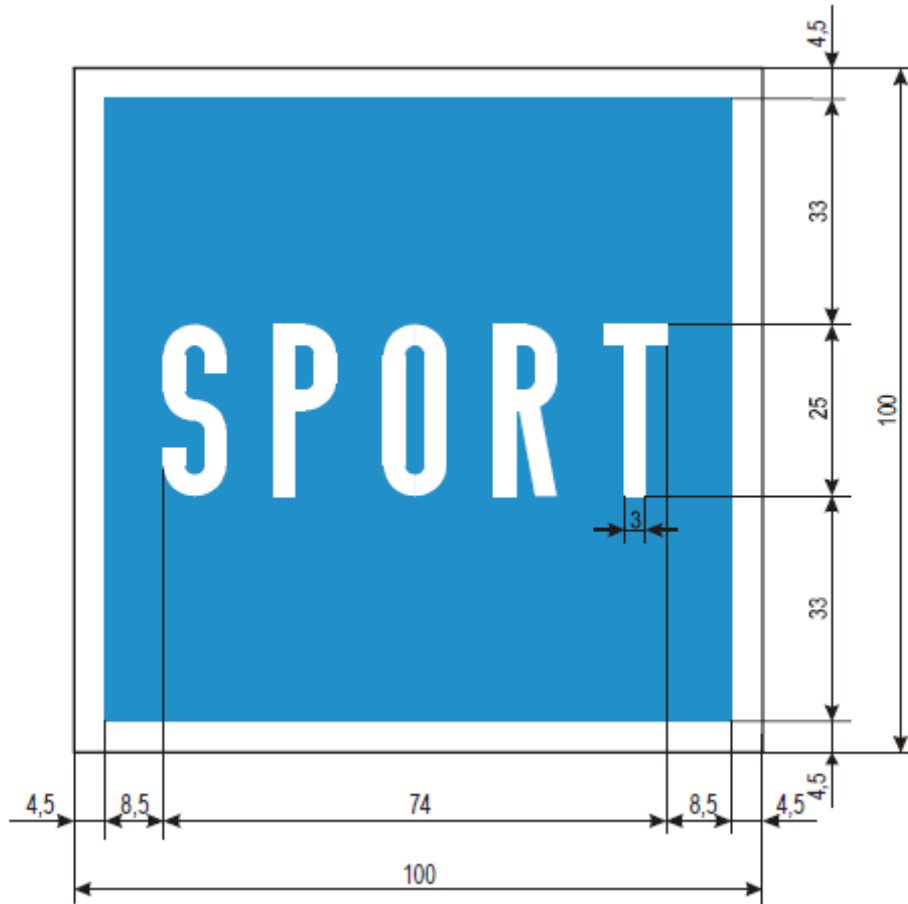

**E.17**

(Water skiing permitted)

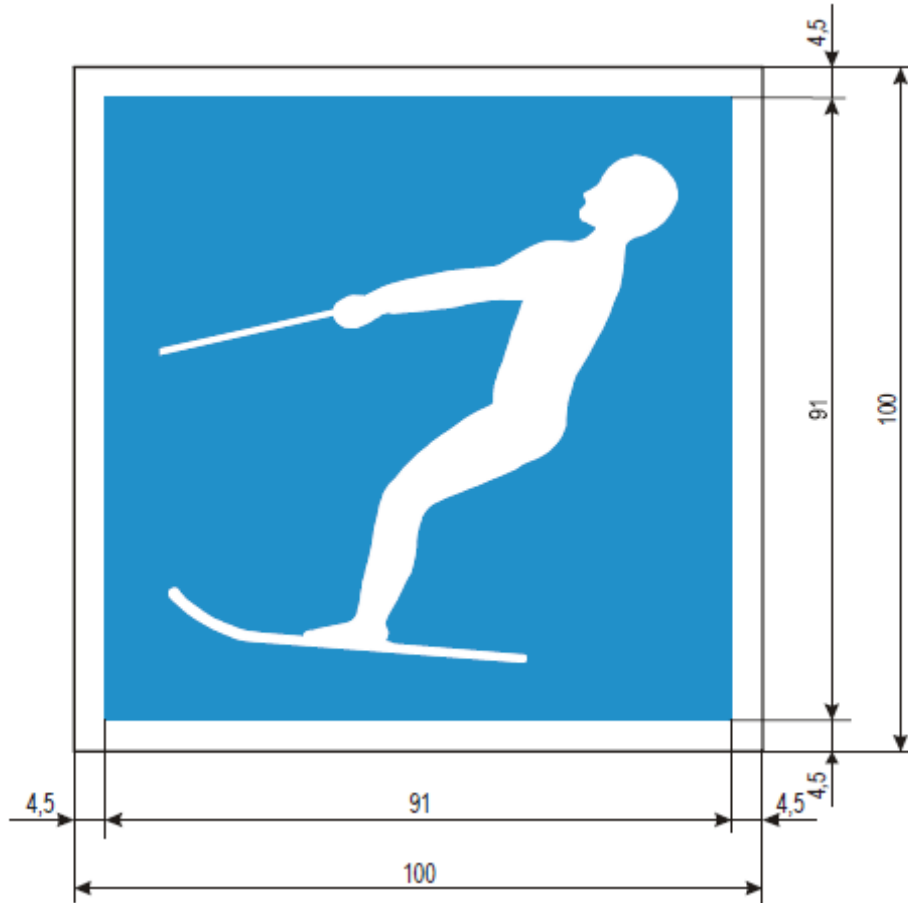

**E.18**

(Sailing vessels permitted)

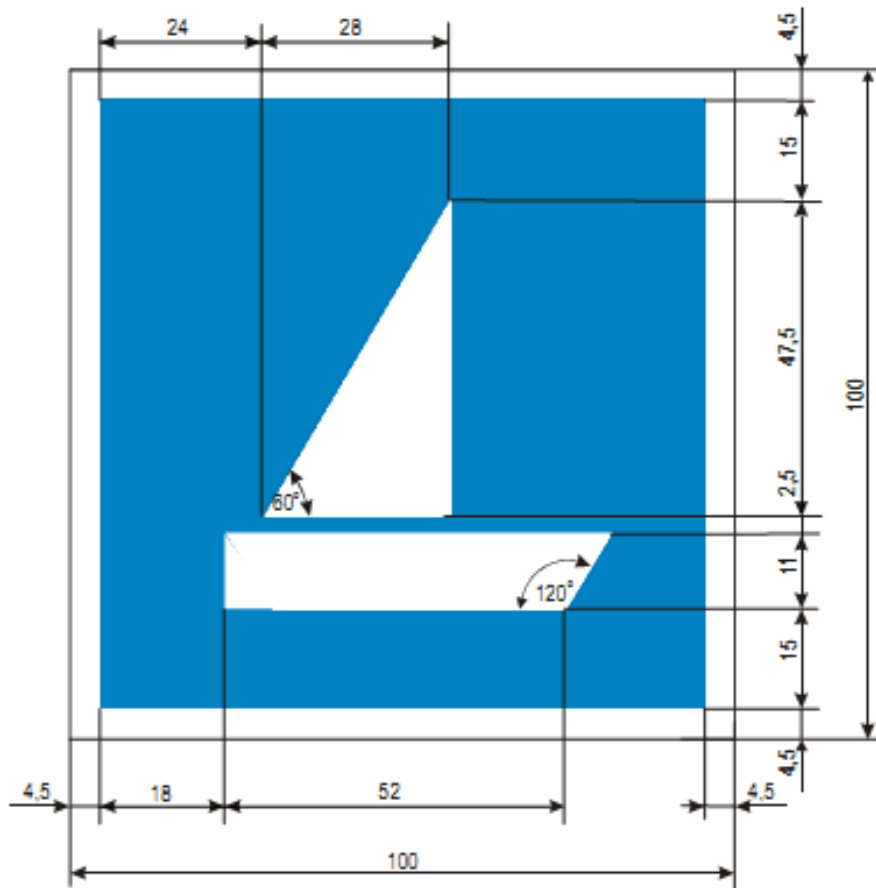

**E.19**

(Craft other than motorized vessels or sailing craft premitted)

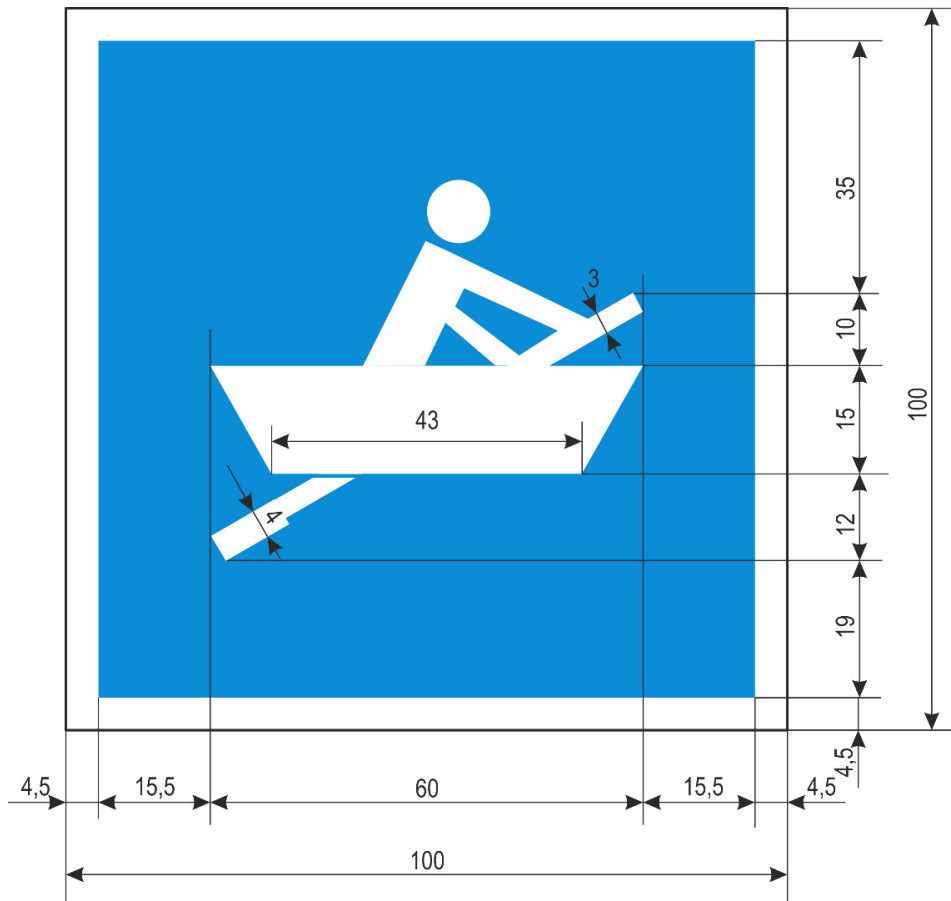

**E.20**

(Use of sailboards permitted)

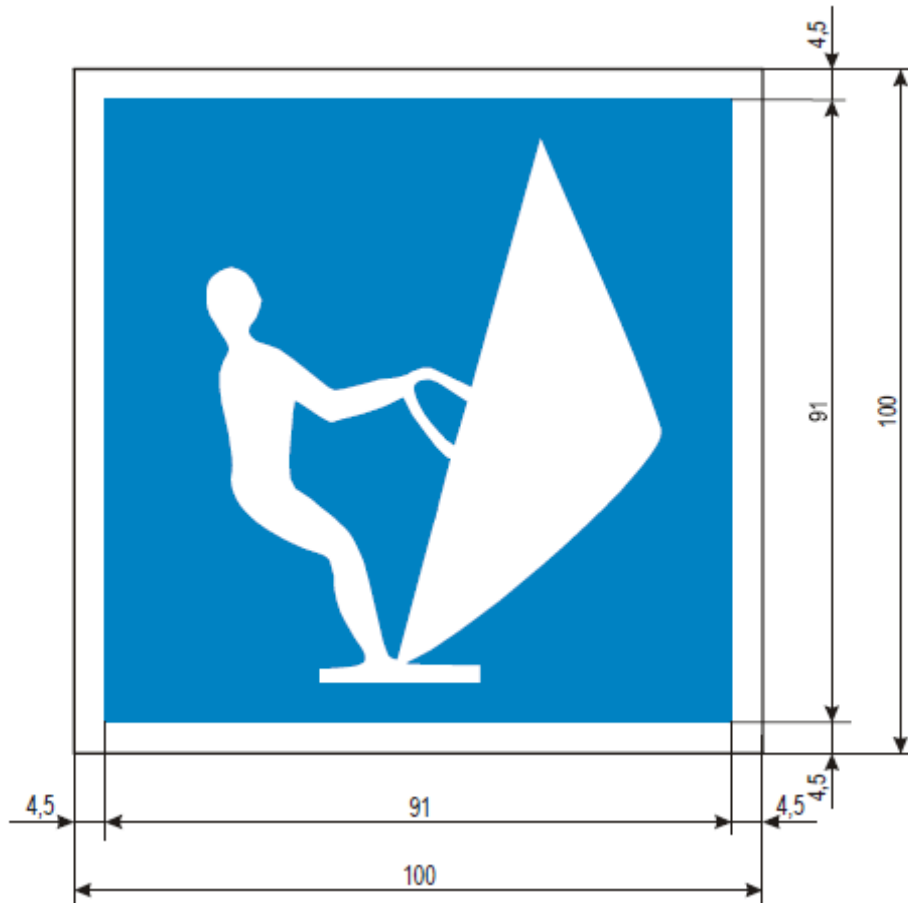

**E.21**

(Zone authorized for high speed navigation of small sport and pleasure craft)

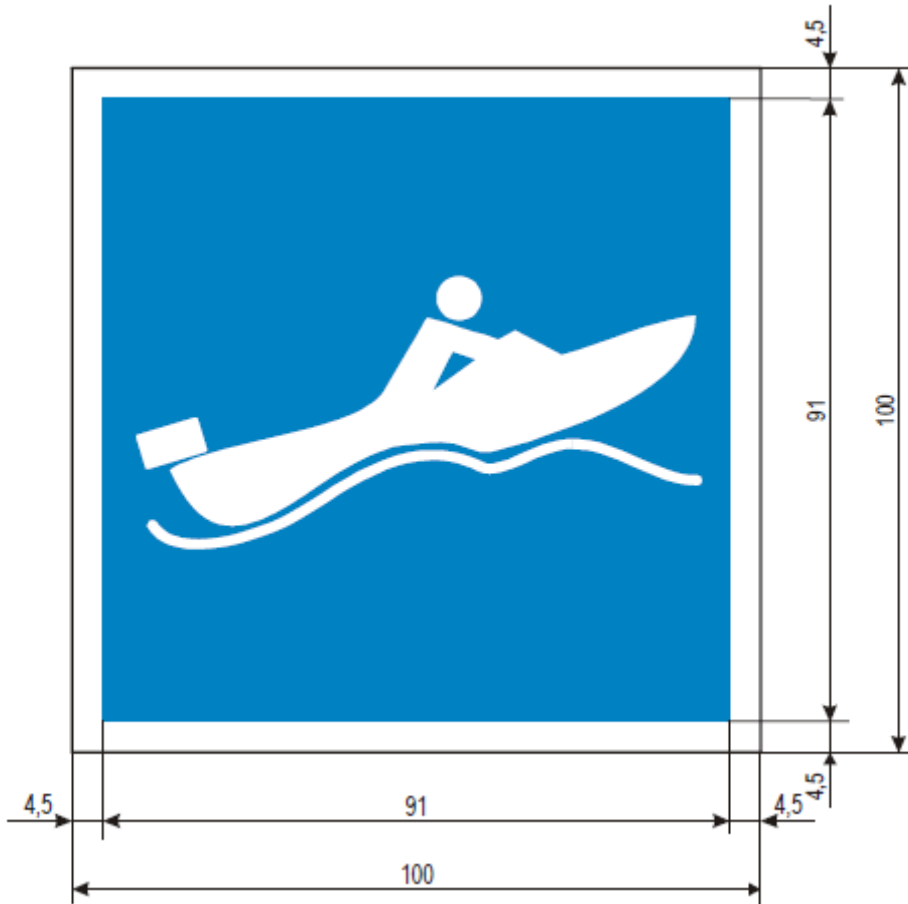

**E.22**

(Launching or beaching of vessels permitted)

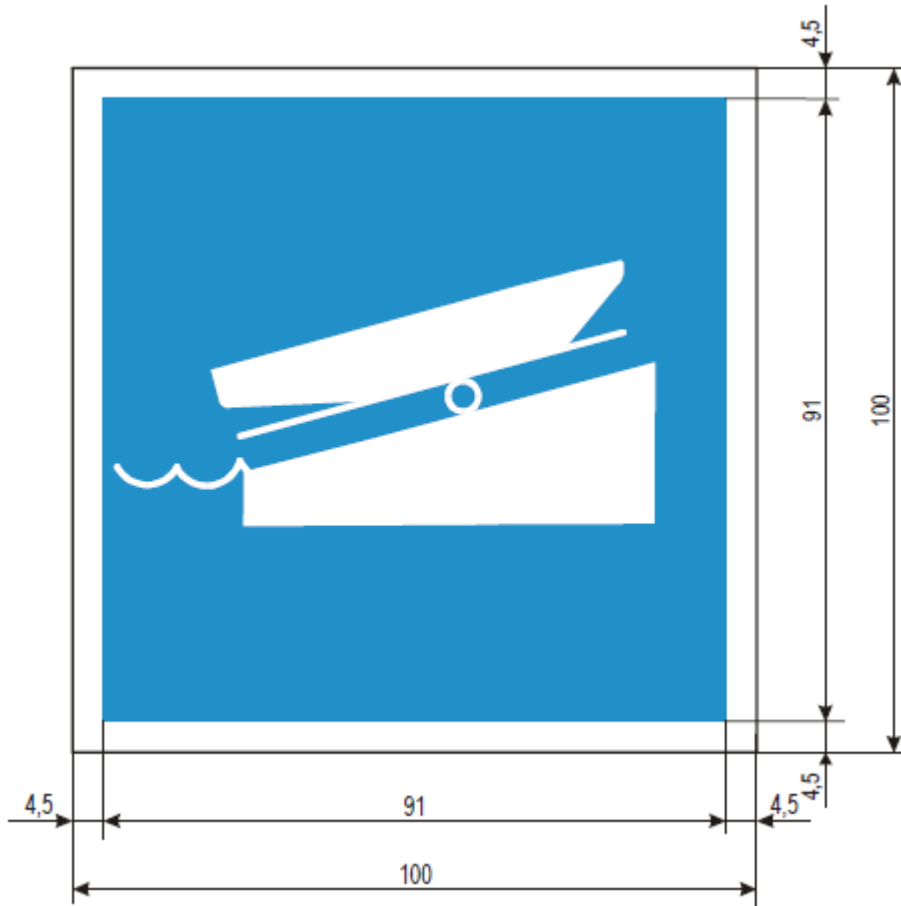



E.23

(Possibility of obtaining nautical information by radio-telephone on the channel indicated)

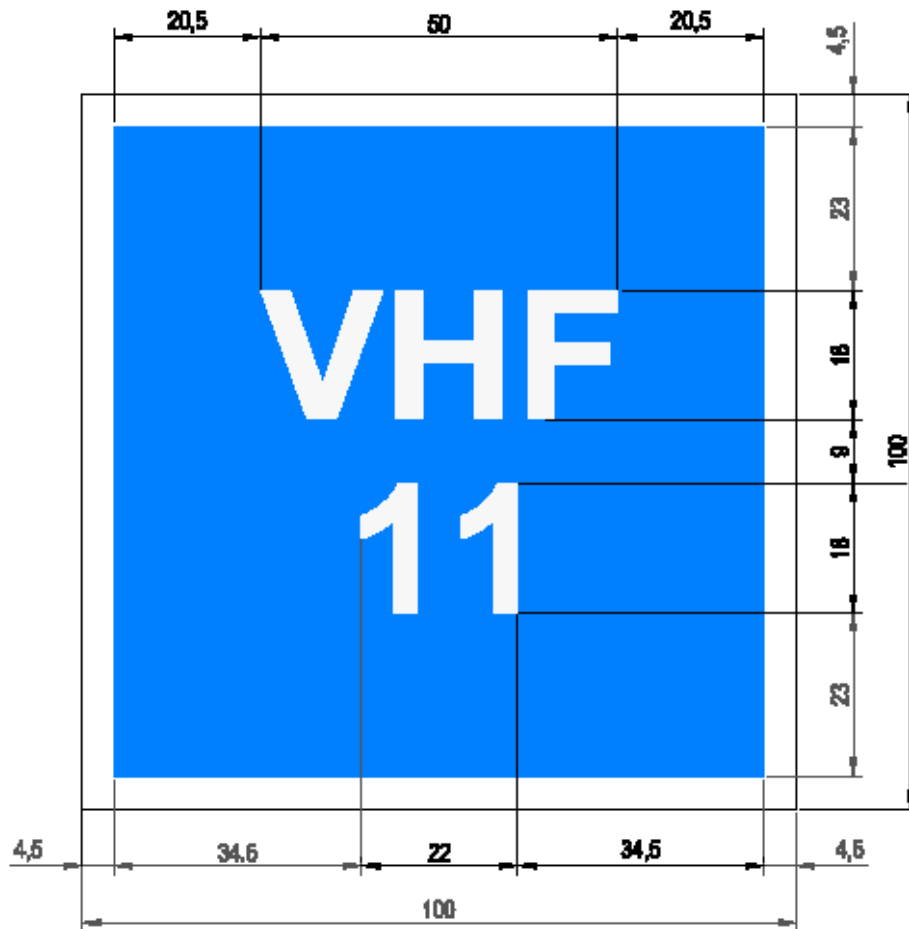

**E.24**

(Water bikes permitted)

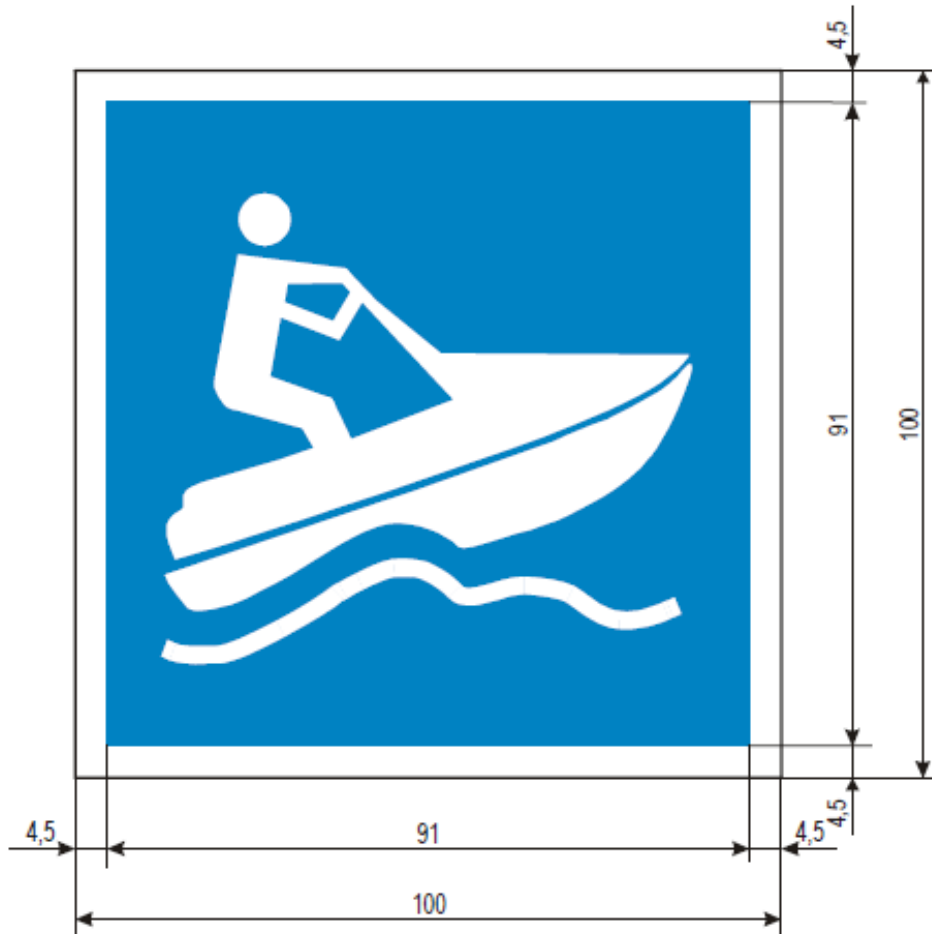

**E.25**

(Available power supply)

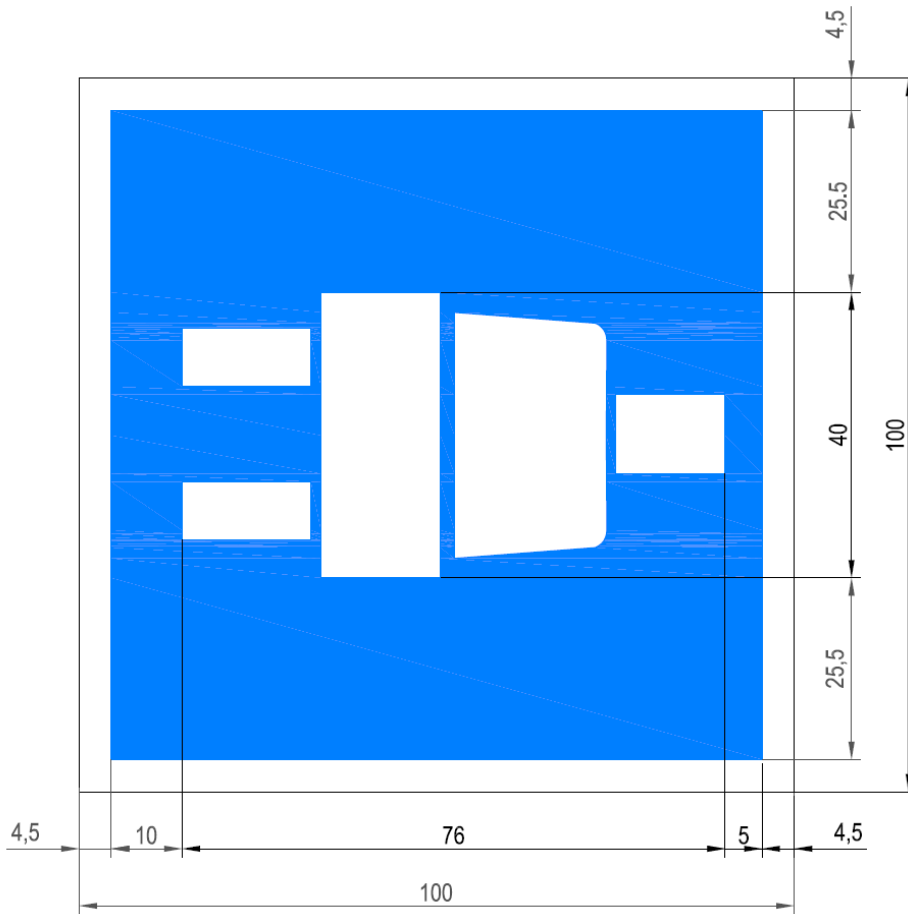

**E.26**

(Winter harbour)

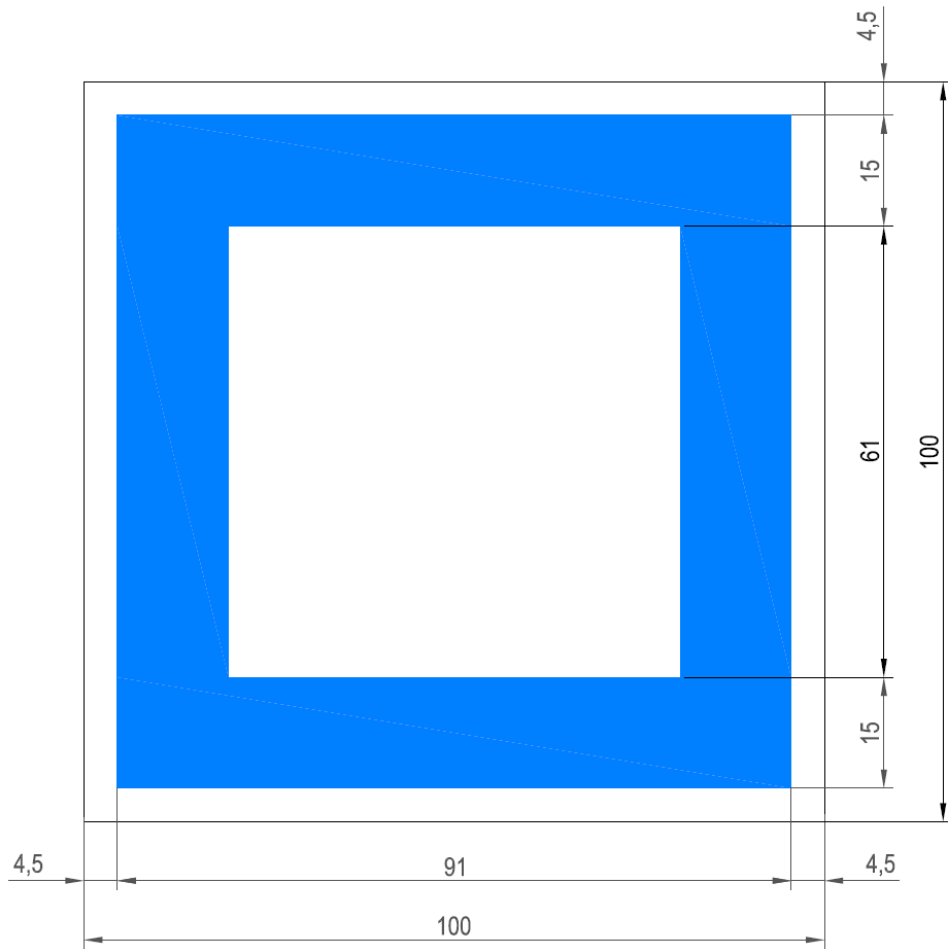

**E.26.1**

(Maximum number of vessels allowed in the winter harbour)

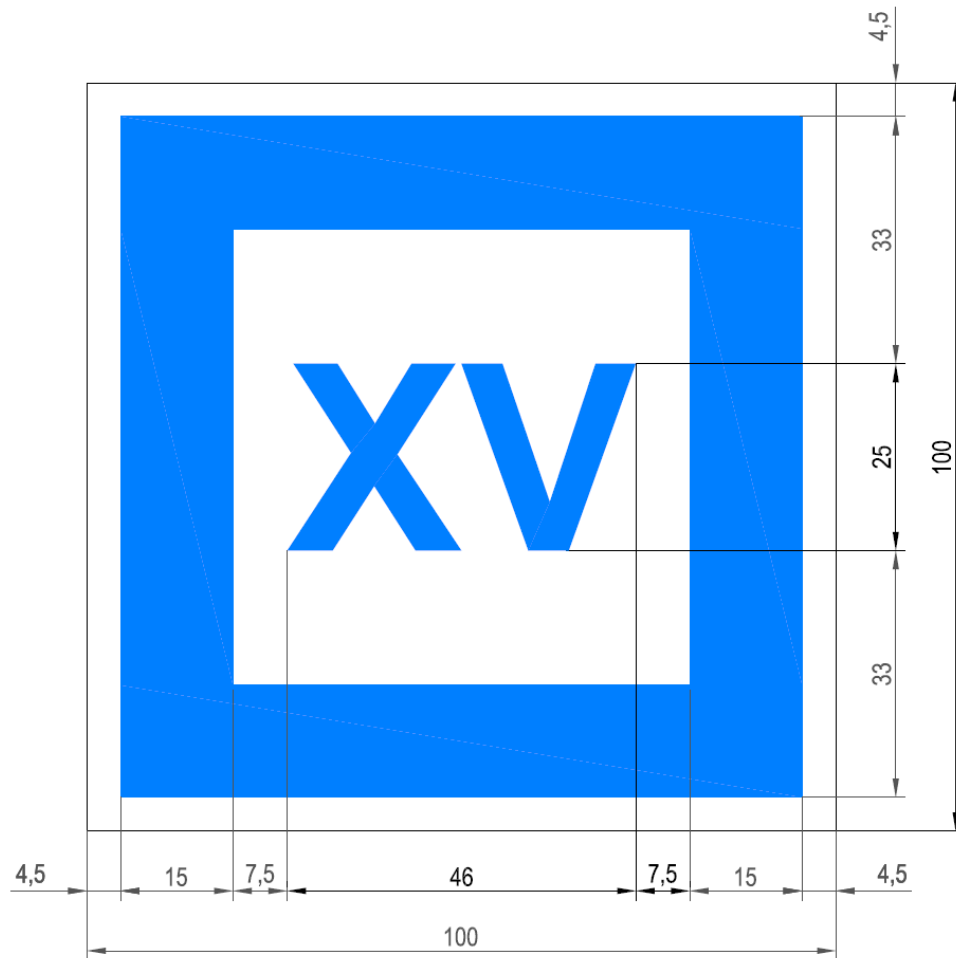

**E.27**

(Winter shelter)

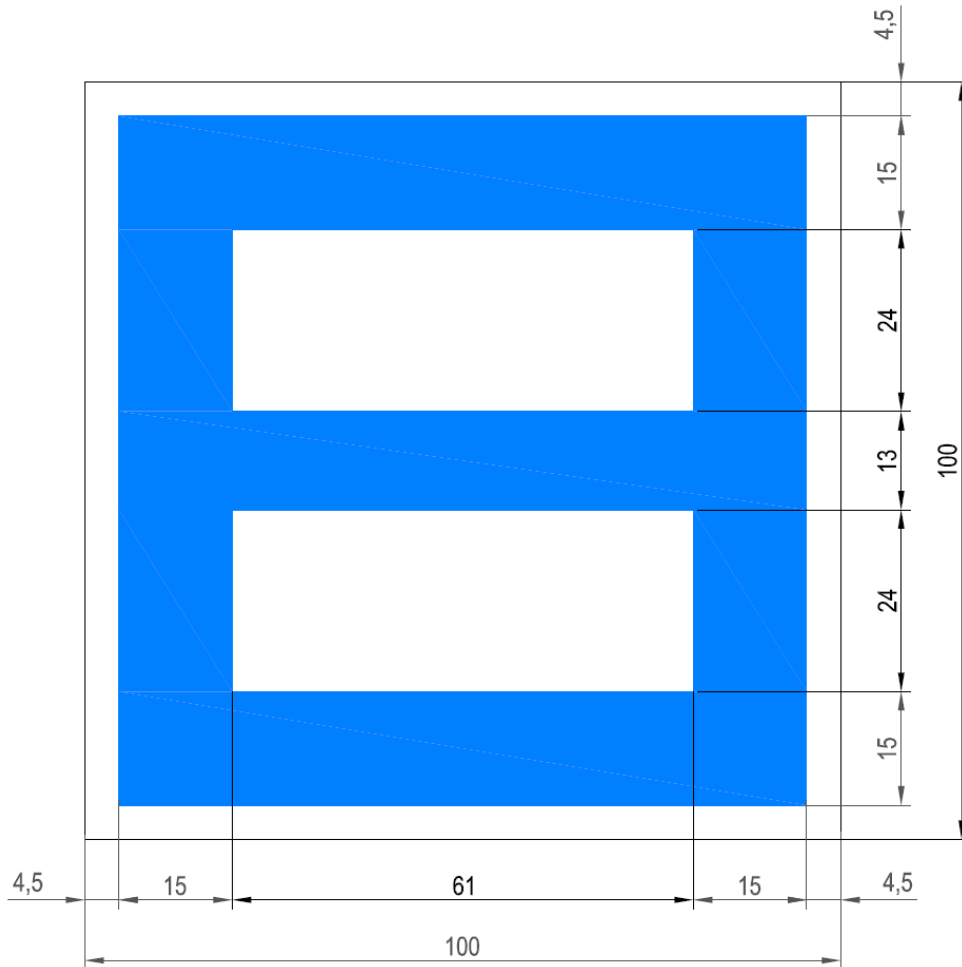

### E.27.1

(Maximum number of vessels allowed in the winter shelter )

- Maximum number of vessels permitted to berth abreast
- Maximum number of rows of vessels permitted to berth abreast

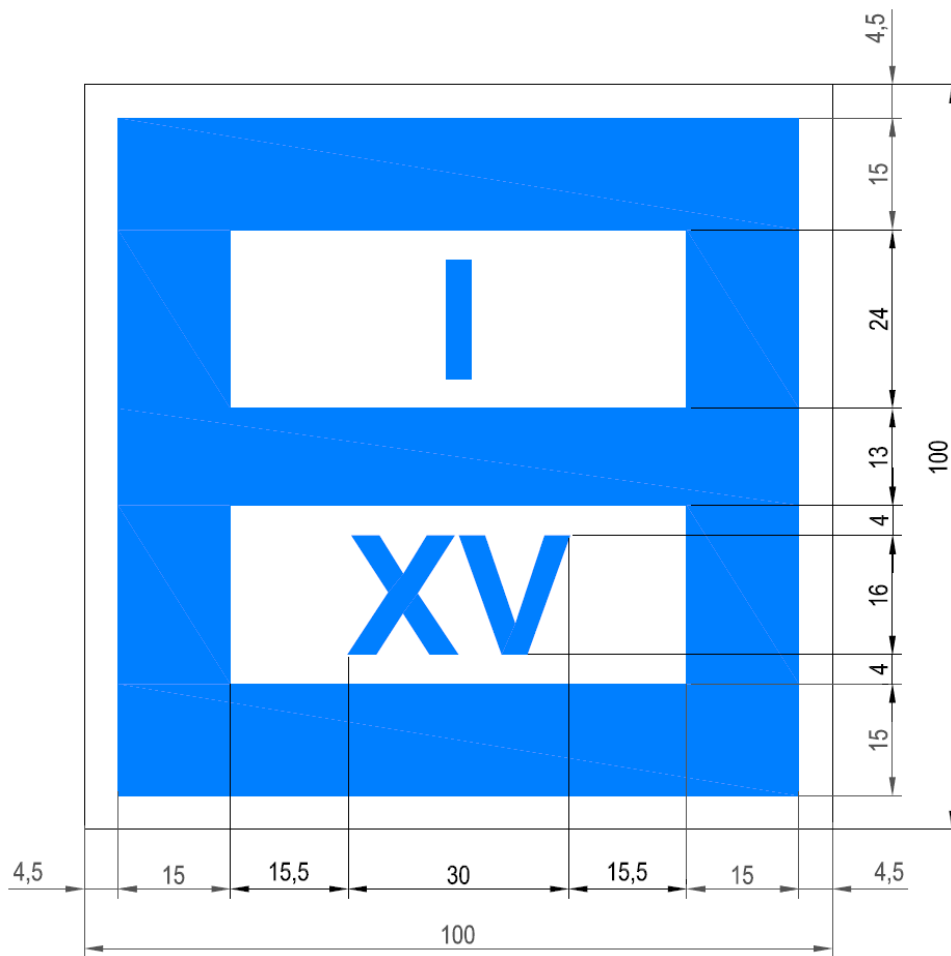

**Section II: Auxiliary signs**

**Section II.1 Panels showing the distance at which the regulation applies or the special feature indicated by the main sign is to be found**

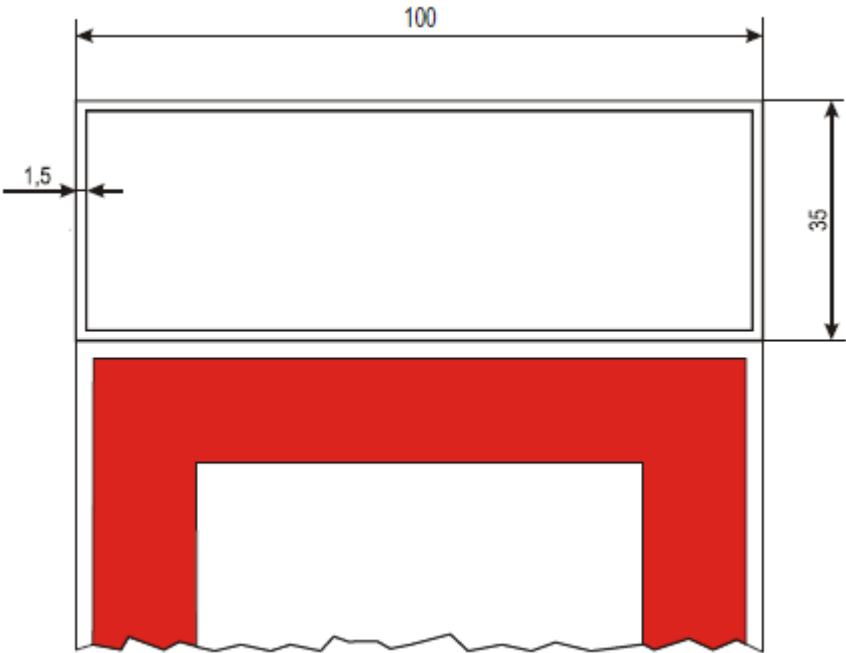



**Section II.2 Panels showing the distance at which the regulation applies or the special feature indicated by the main sign is to be found**

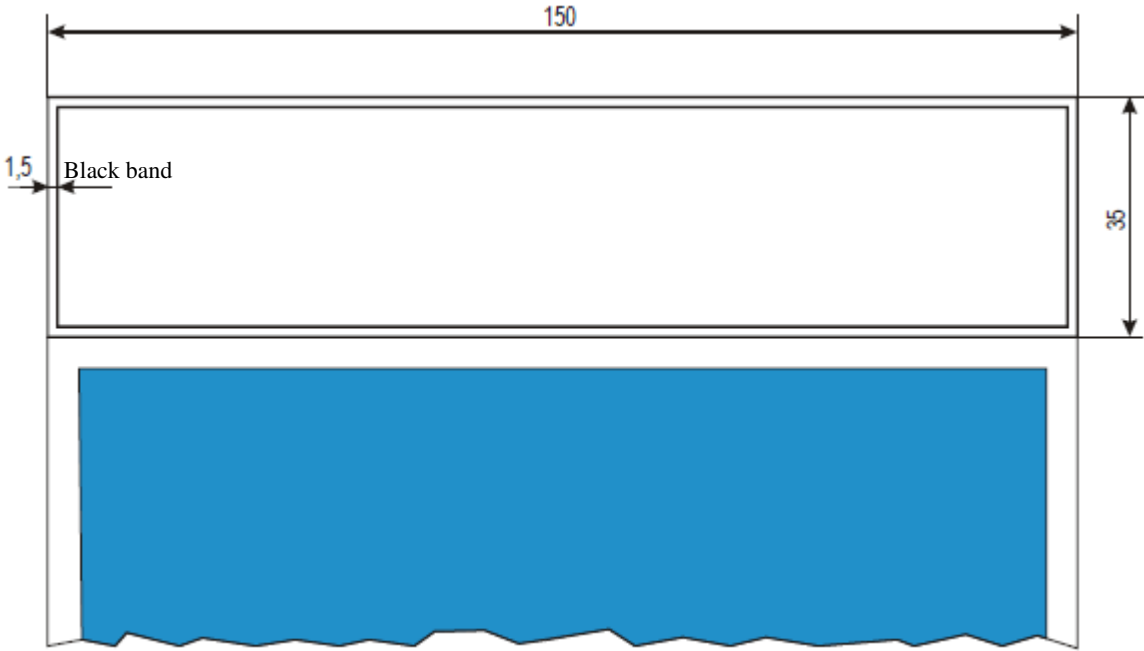

**Section II.3 Pointers showing the direction of the section to which the main sign applies**

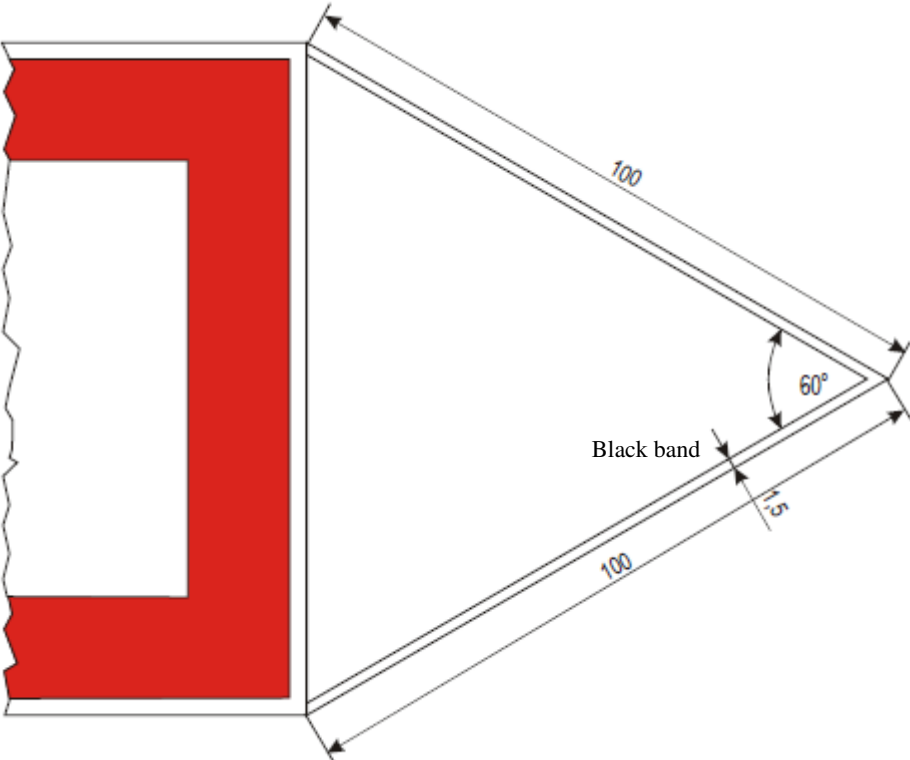

**Section II.4 Panels giving explanations or additional information**

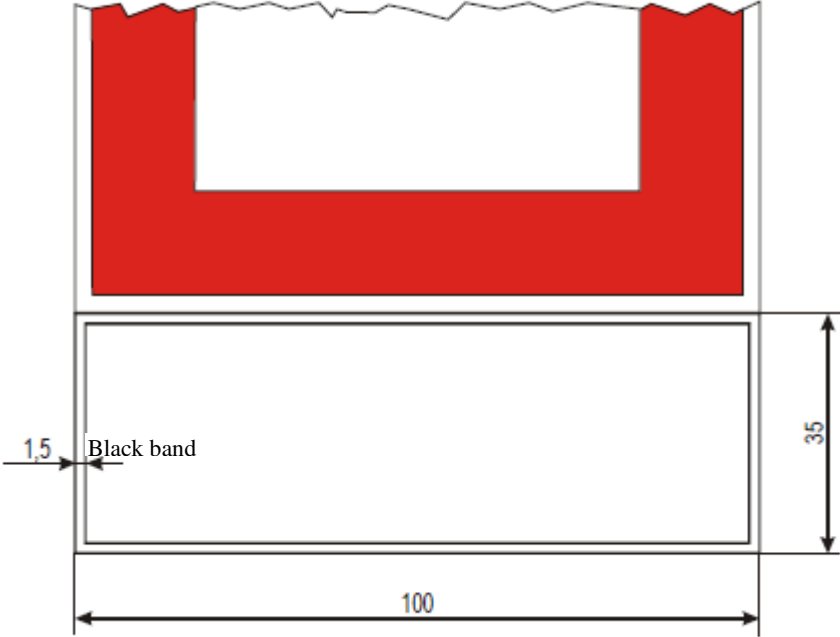

**3. Minimal dimensions of the signs contained in annex 8 to the Navigation rules in the Sava river basin**

**3.1 Buoyage of fairway limits in the waterway**

**1.B**  
(Red bouy without light)

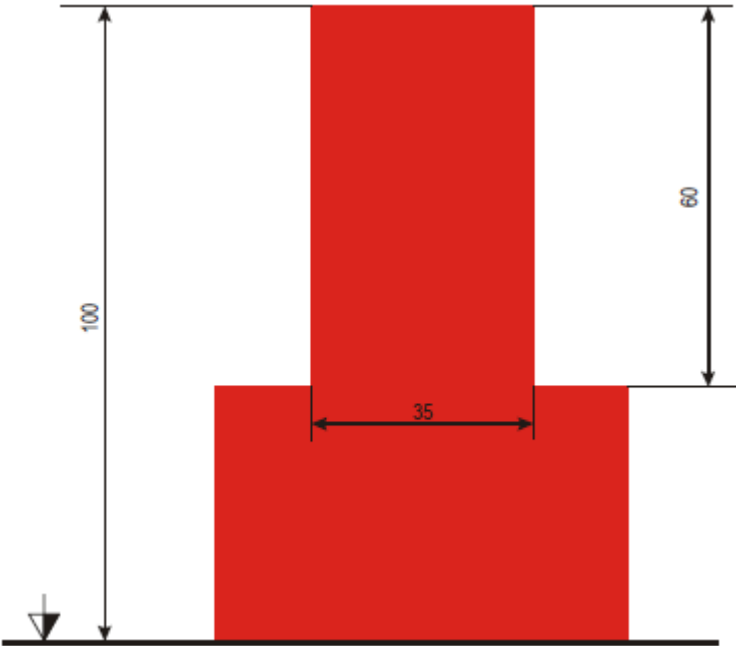

**1.D**  
(Red spar)

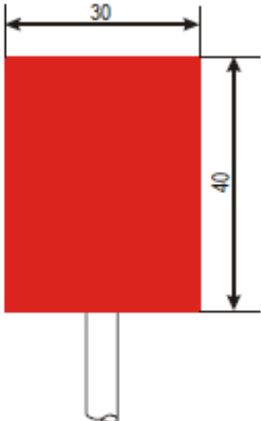

**2.B**

(Green bouy without light)

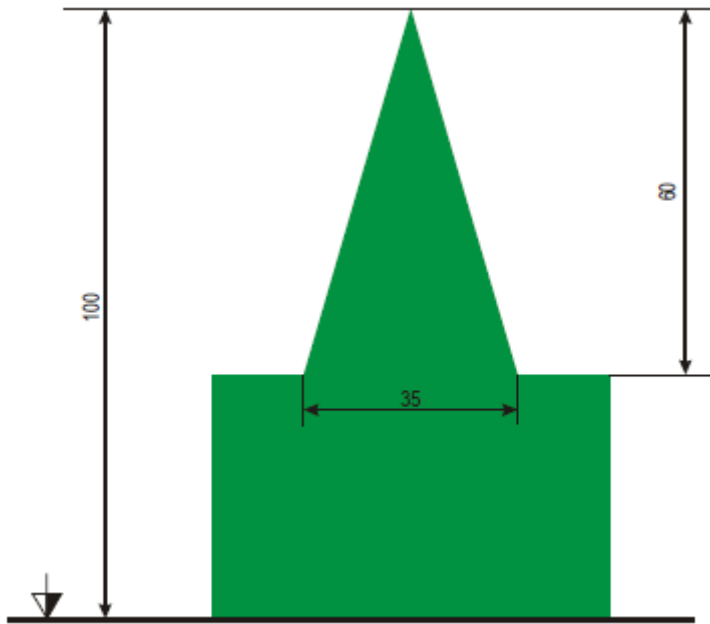

**2.D**

(Green spar)

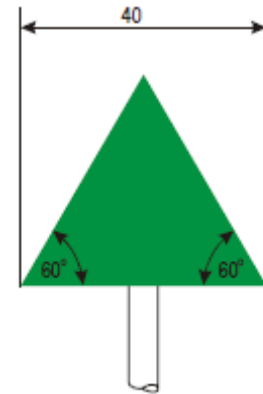

**3.B**  
(Bifurcation buoy)

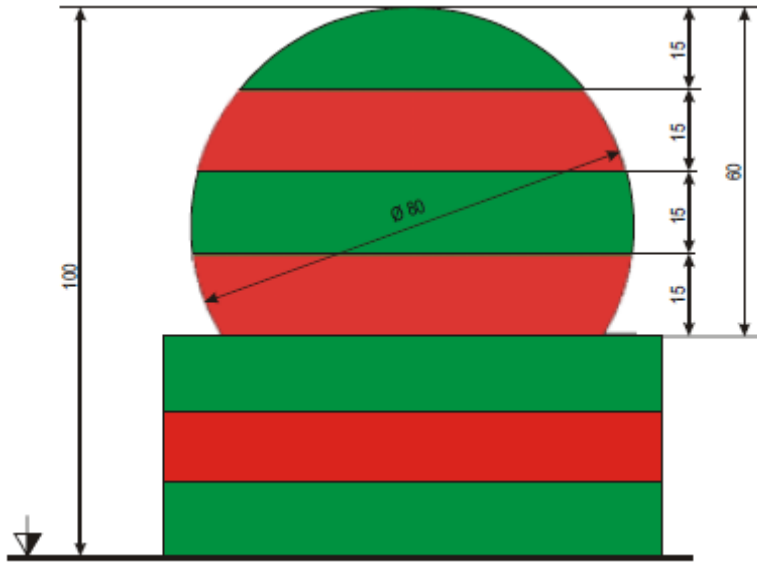

**3.D**  
(Bifurcation spar)

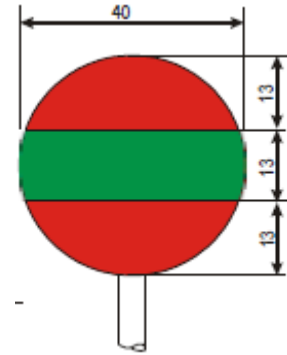

3.2 Bank marks indicating the position of the fairway

4.B

(Fairway near the right bank - Bank mark without light)

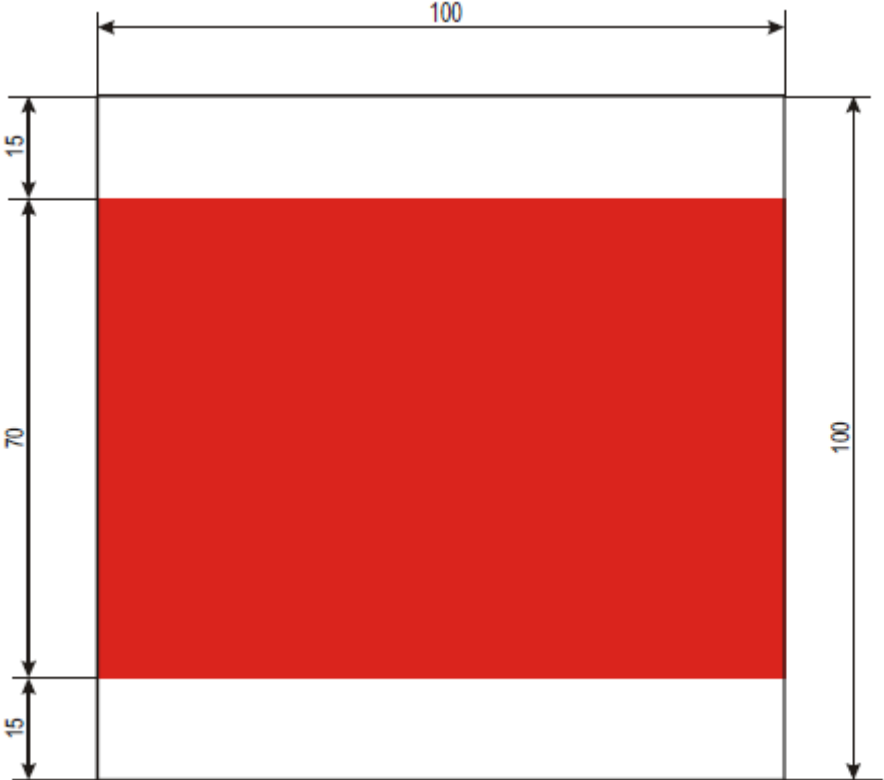

**5.B**

(Fairway near the left bank - Bank mark without light)

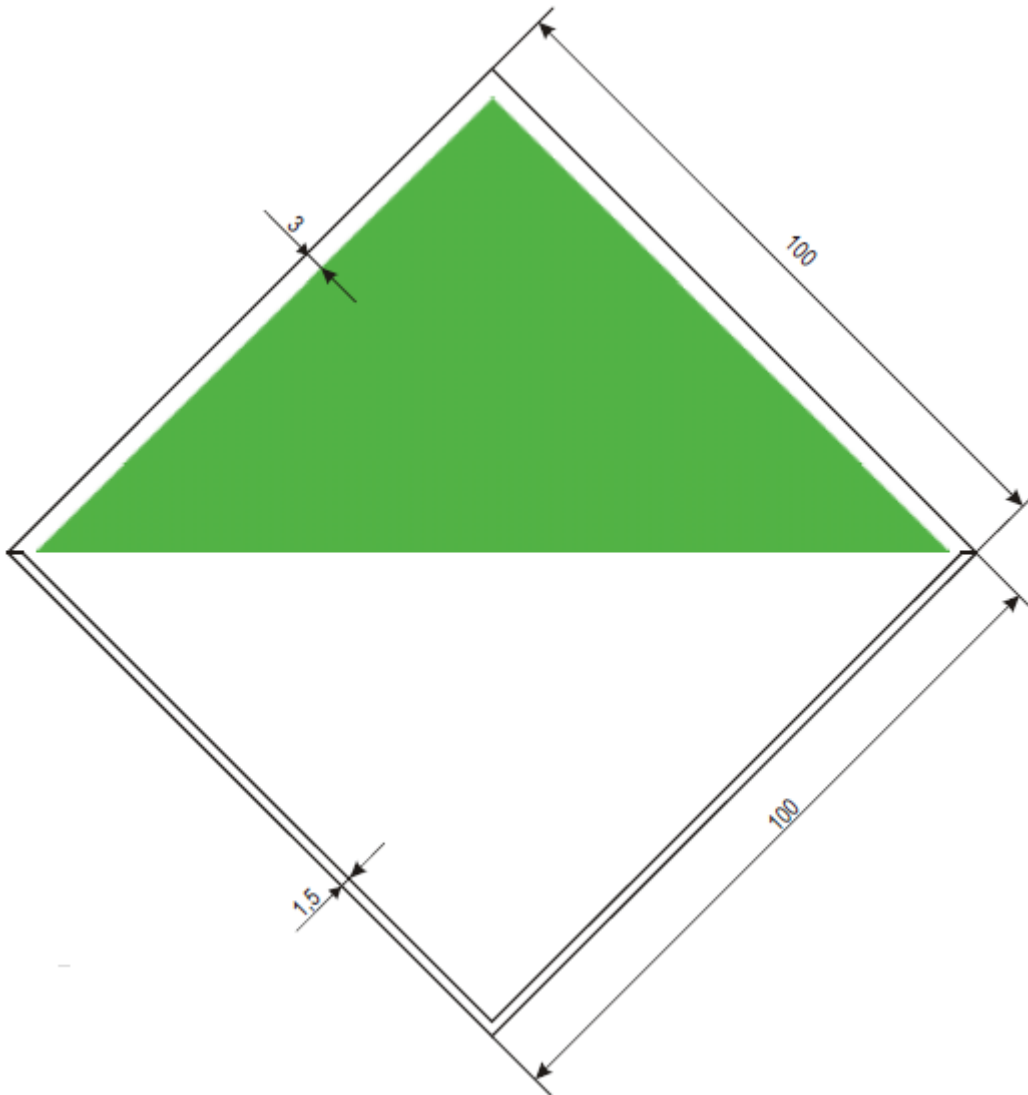



#### 4.D

(Marking cross-overs - Right bank: Bank mark without light)

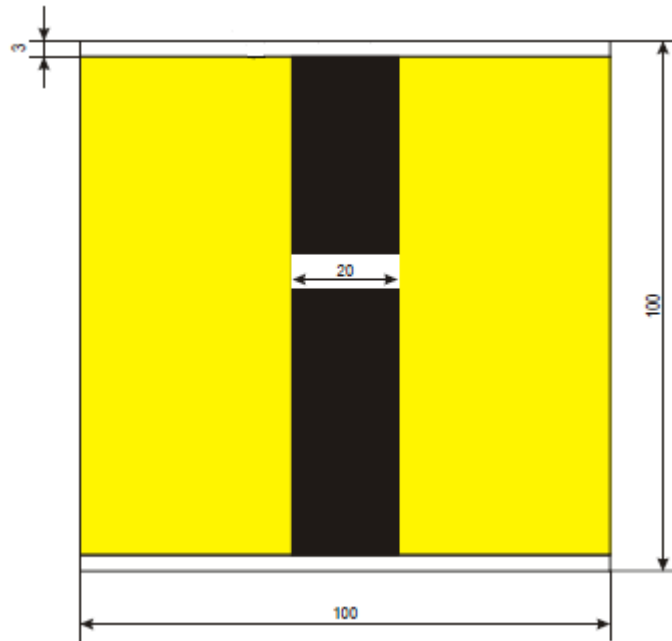

**5.D**

(Marking cross-overs - Left bank: Bank mark without light)

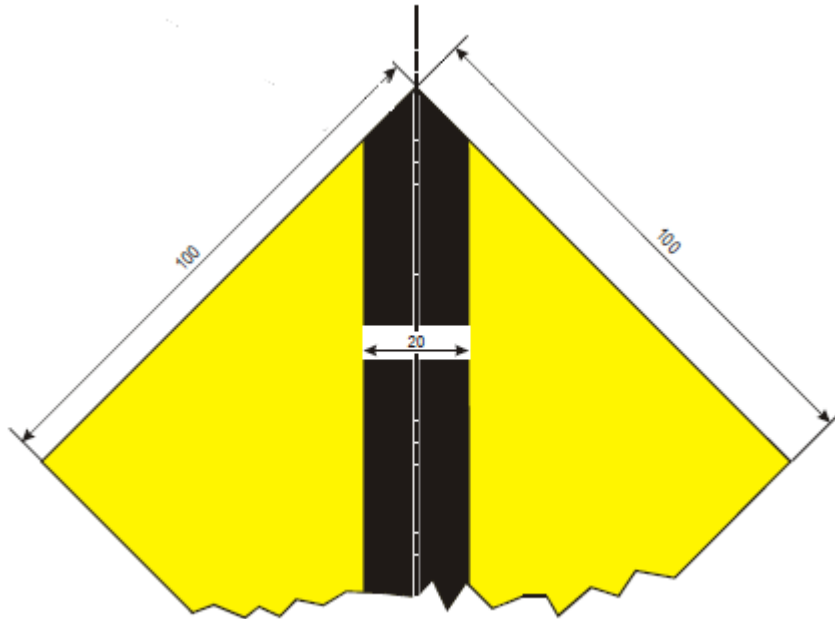

**CEVNI Annex 8 – 3.2**

(Indication of the axis of a long cross-over)

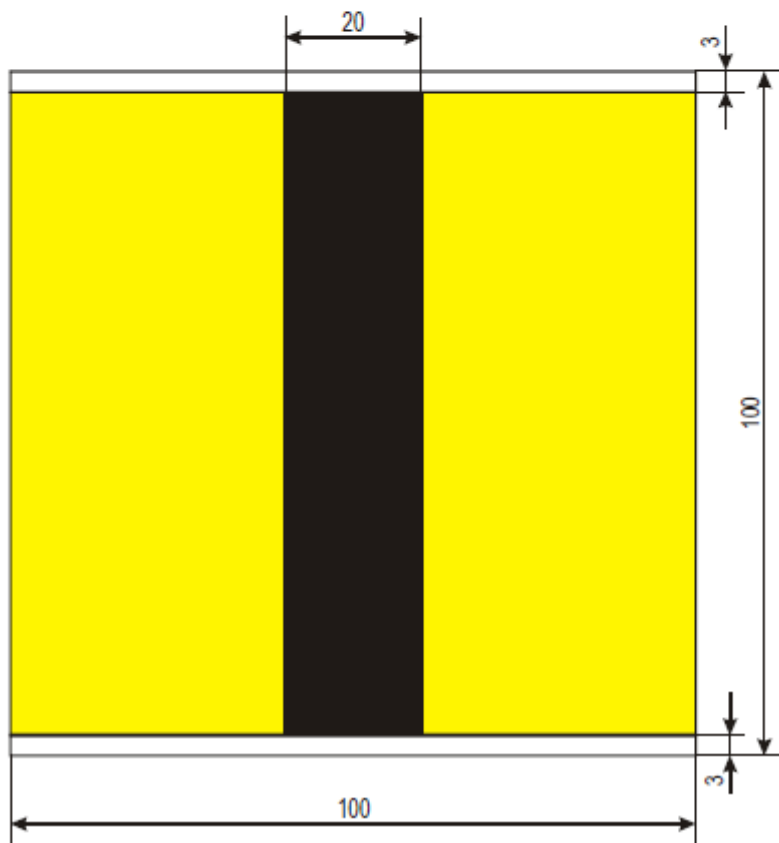
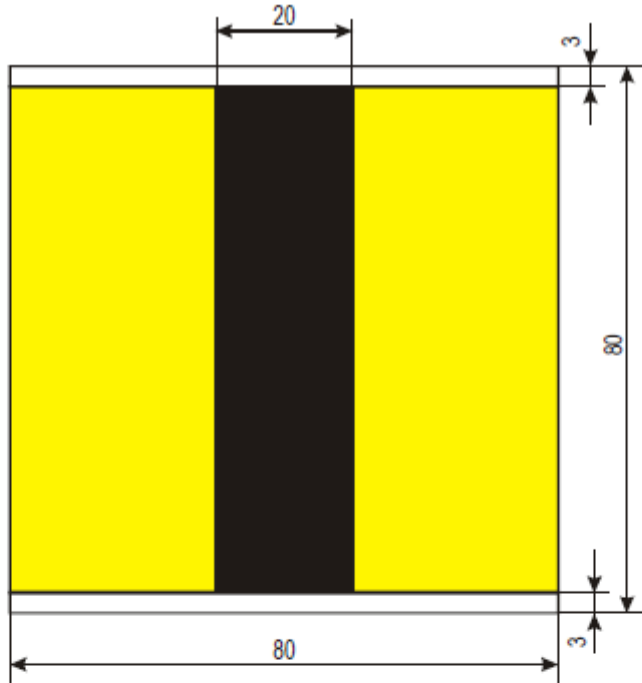

**CEVNI Annex 8 – 3.2**

(Indication of the axis of a long cross-over)

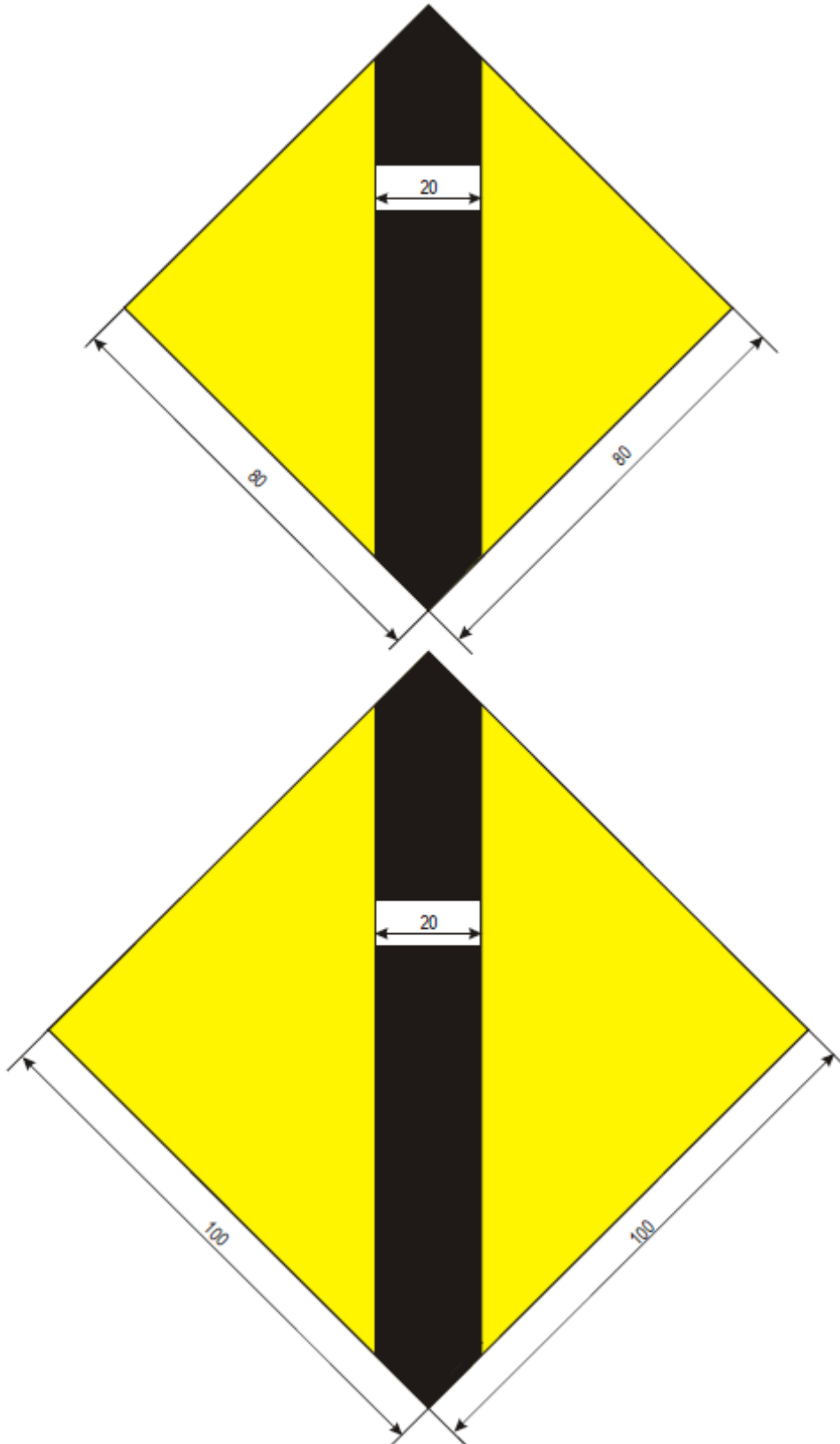

3.3 Buoyage and marking of danger points and obstacles

4.F

(Right-hand side: Bank mark)

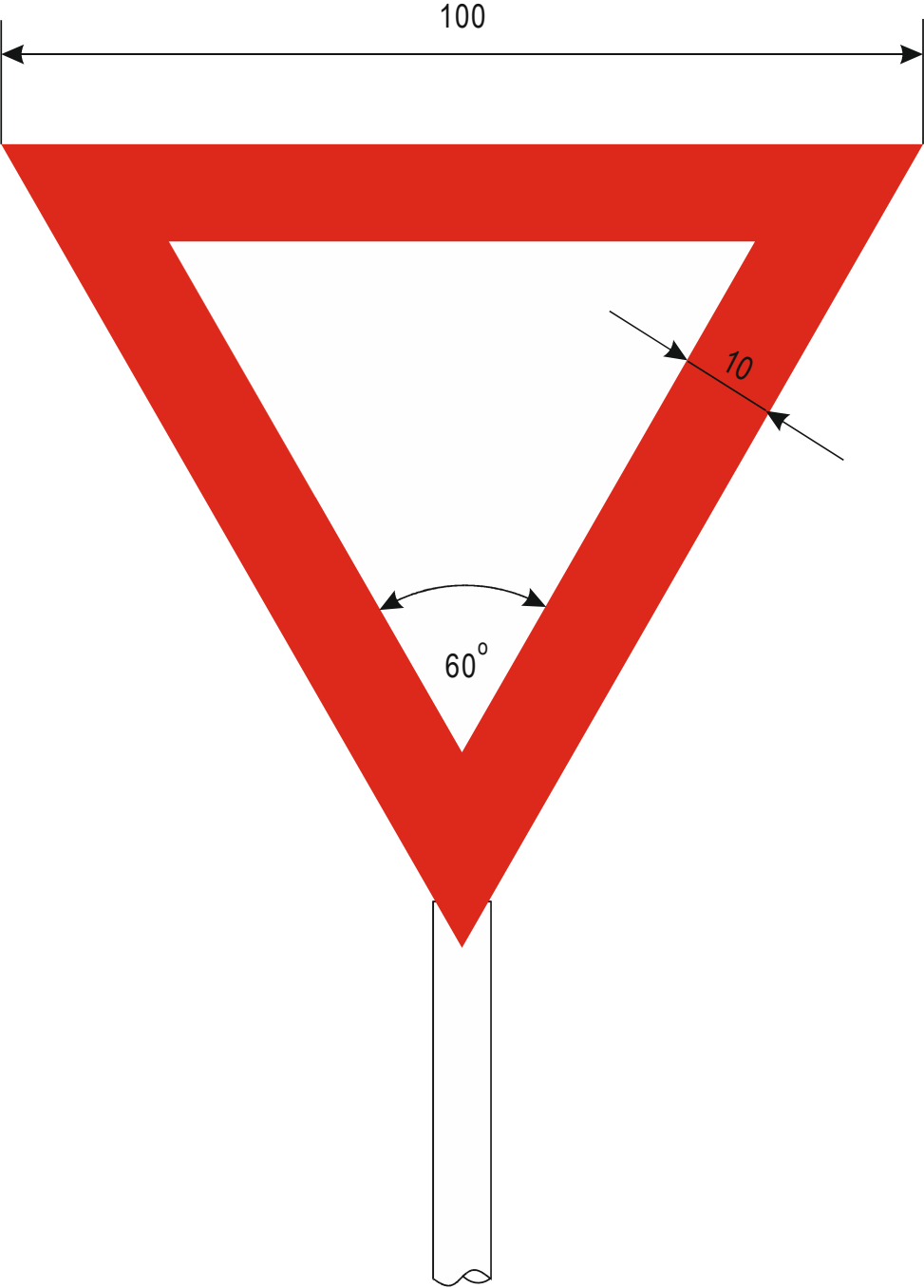

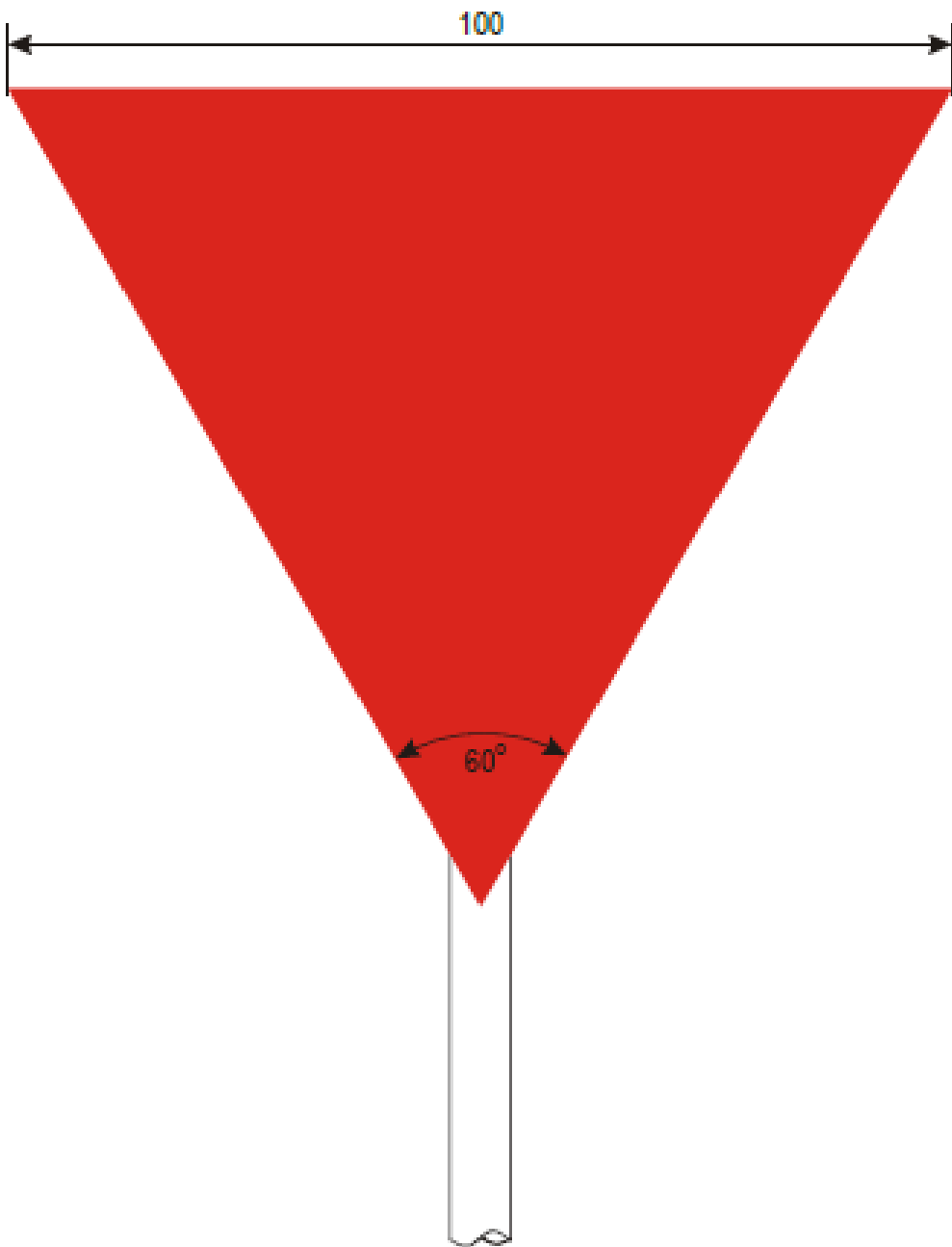

**5.F**

(Left-hand side: Bank mark)

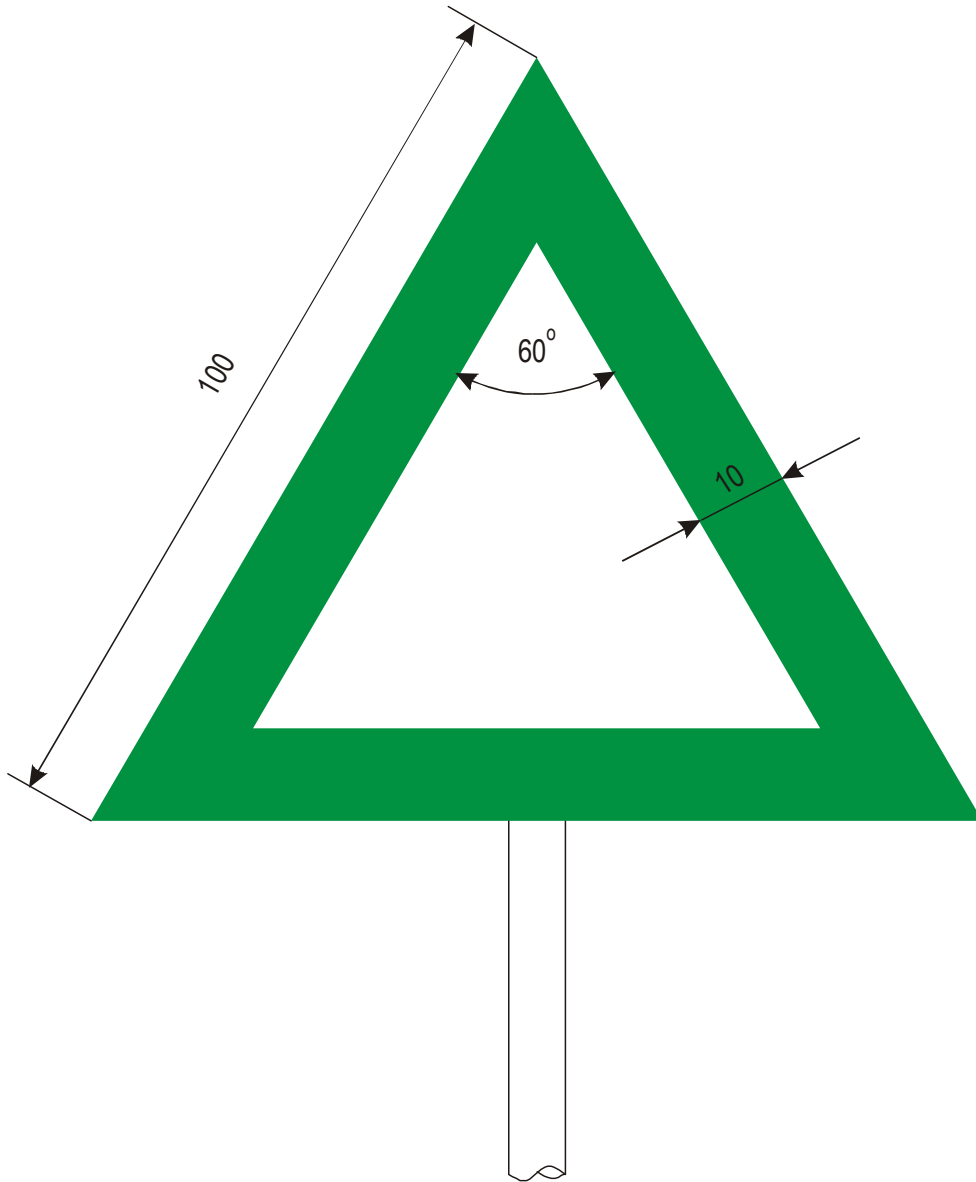

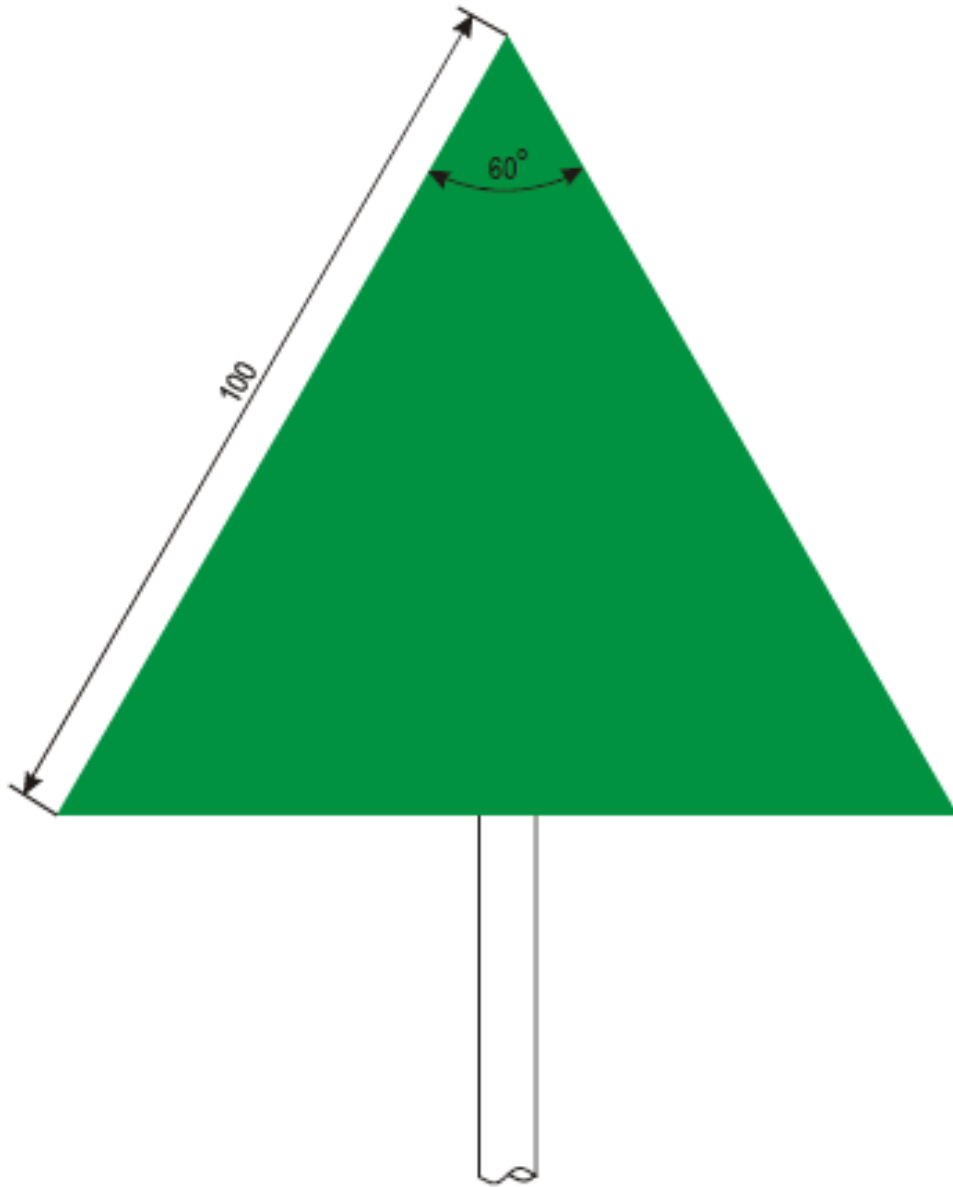



**6.B**

(Bifurcation without light: Fixed mark)

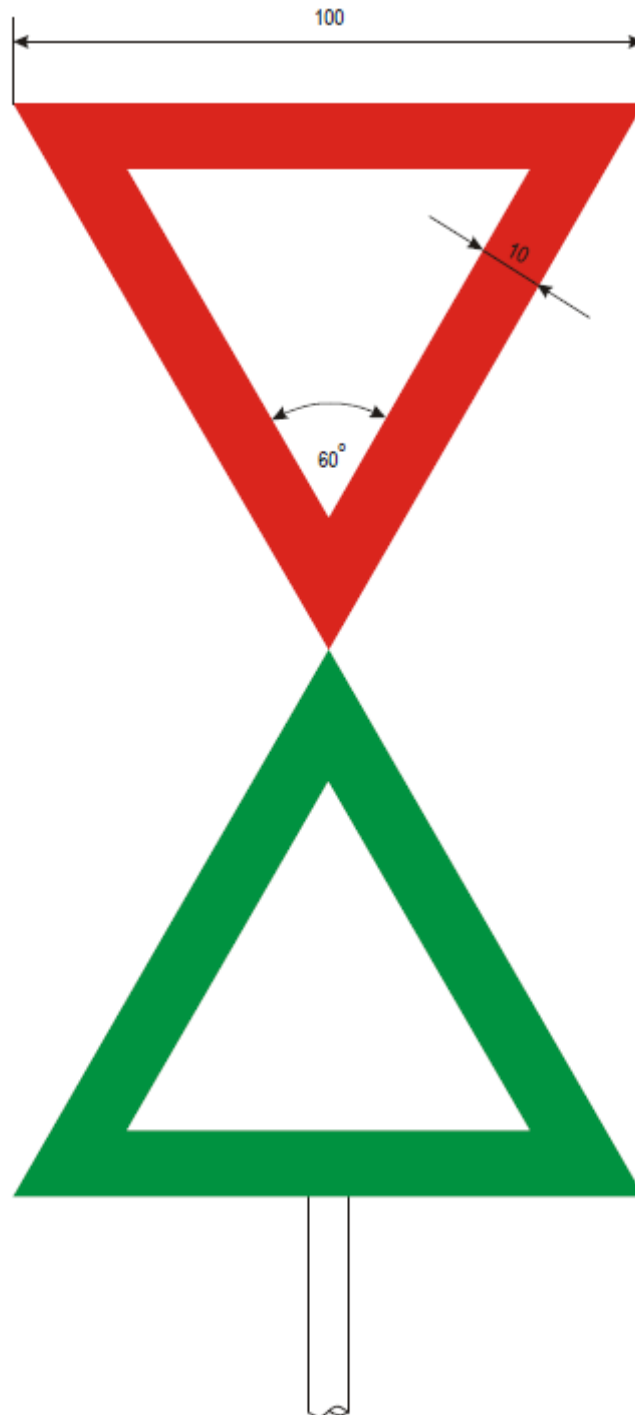

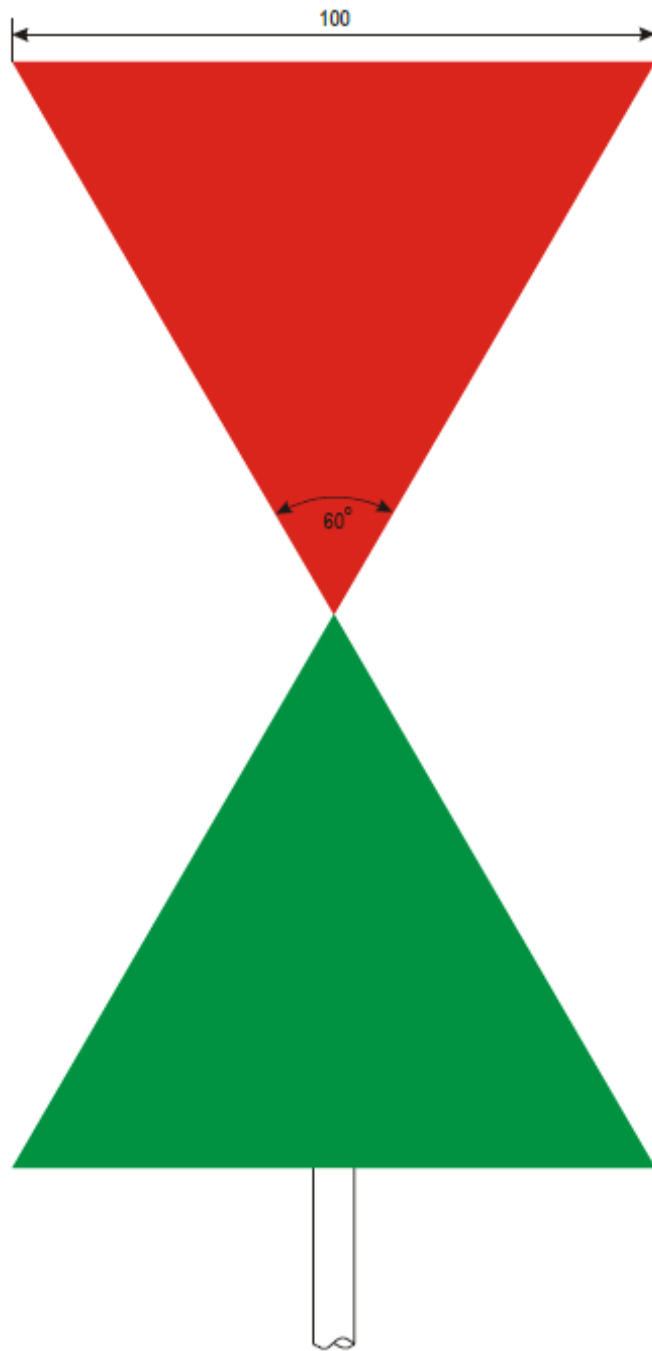

**1.F**

(Right hand side: Red buoy with a spar)

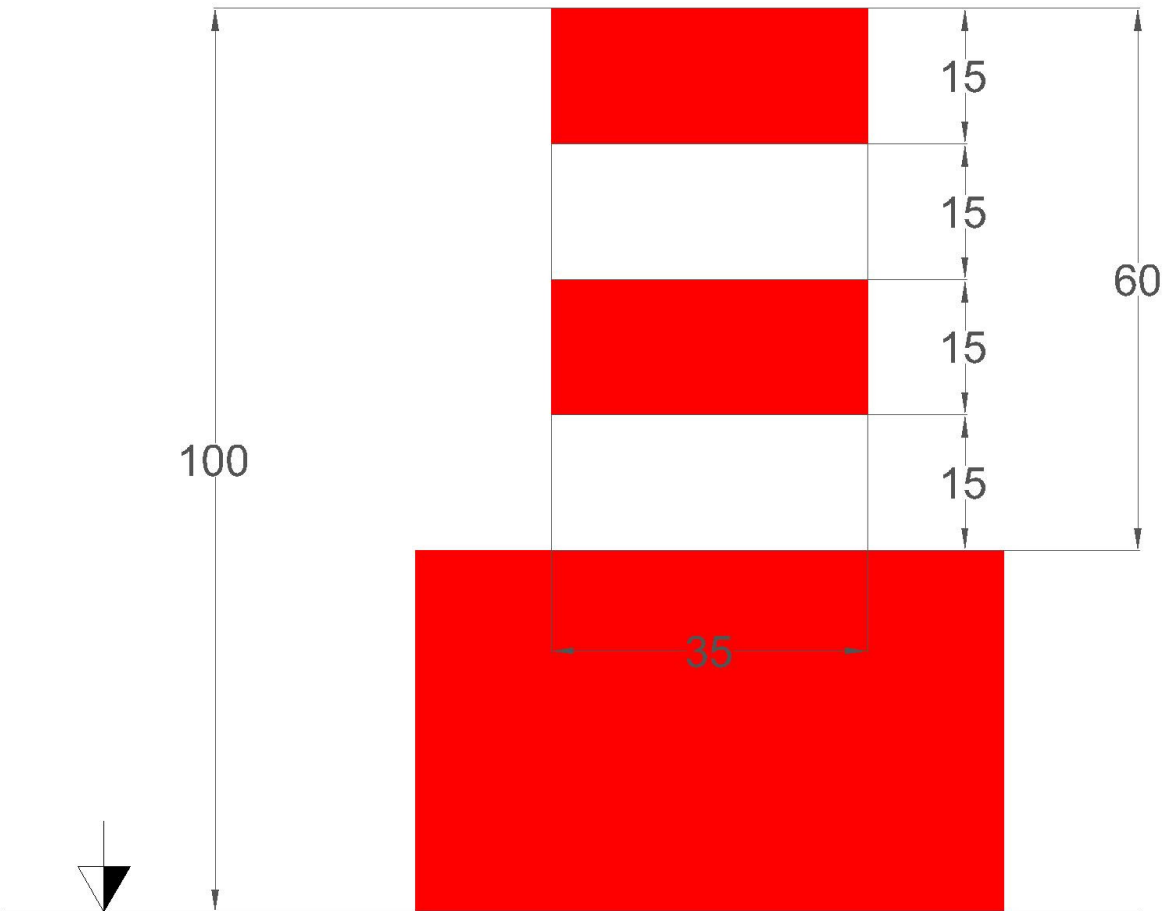

2.F

(Left hand side: Green buoy with a spar)

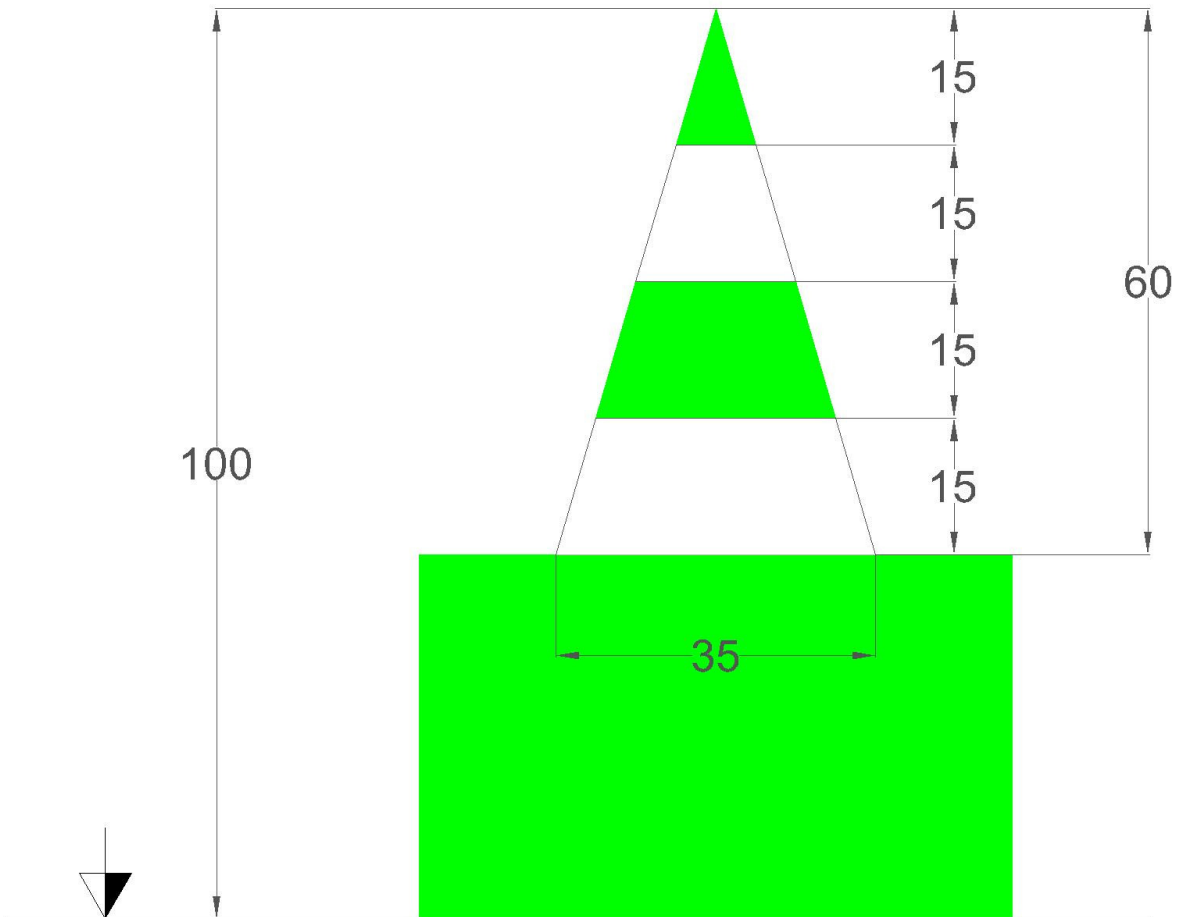

### 3.4 Radar reflectors on marking signs and signals and navigable passes through bridges

**Radar reflector on bridges**

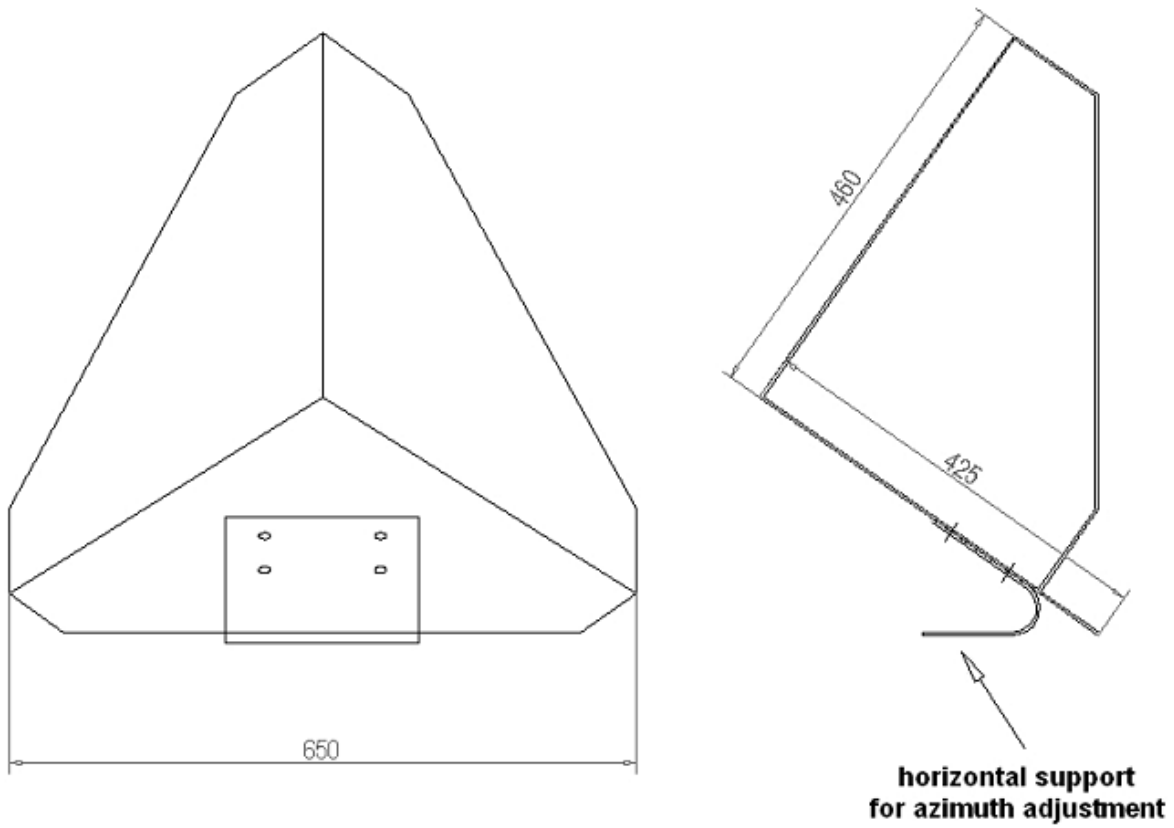

**Radar reflector on buoys and markers**

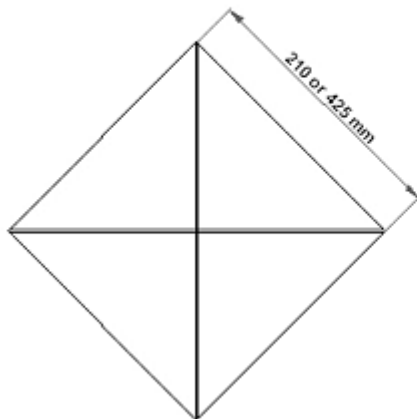
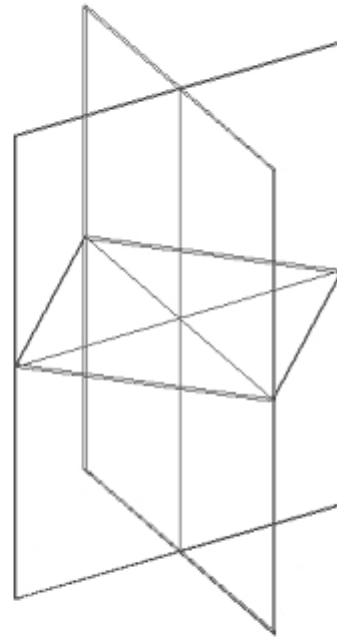
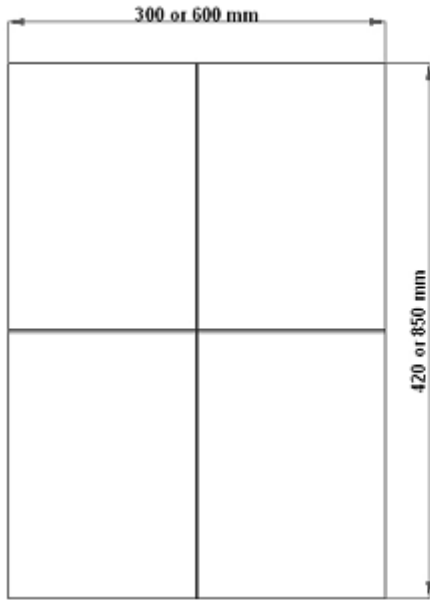

## ANNEX 2 PROPERTIES OF LIGHTS

### 1. Categories of luminous intensity

Lanterns are classified according to their horizontally emitted photometric luminous intensity  $I_{ph}$ , in candelas (cd).

By analogy with luminous intensity for lights on board vessels, three distinct categories have been established, according to power.

**Table 1**

<i>Category</i>	<i>By analogy with</i>	<i>Intensity of white light [cd]</i>	<i>Intensity of red/green/yellow light [cd]</i>
1	Ordinary light	2–9	0.8–3.5
2	Bright light	9–35	3.5–20
3	Strong light	35–100	20–50

### 2. Acceptable colours of lights

The colours of lights are described in a standard chromatic diagram pursuant to ISO 11664/CIE S 014. The range of colours accepted in the standard chromatic diagram is determined according to standard CIE S 004/E-2001.

The chromatic coordinates for the acceptable ranges are as follows:

**Table 2**

		<i>1</i>	<i>2</i>	<i>3</i>	<i>4</i>
White	x	0.300	0.440	0.440	0.300
	y	0.342	0.432	0.382	0.276
Yellow	x	0.536	0.547	0.613	0.593
	y	0.444	0.452	0.387	0.387
Red	x	0.660	0.680	0.690	0.710
	y	0.320	0.320	0.290	0.290
Green	x	0.009	0.284	0.209	0.028
	y	0.720	0.520	0.400	0.400

The yellow/red/green colour ranges are limited in addition by the curve of the colour spectrum. The ranges of colours are set out in Figure 1.

**Figure 1**

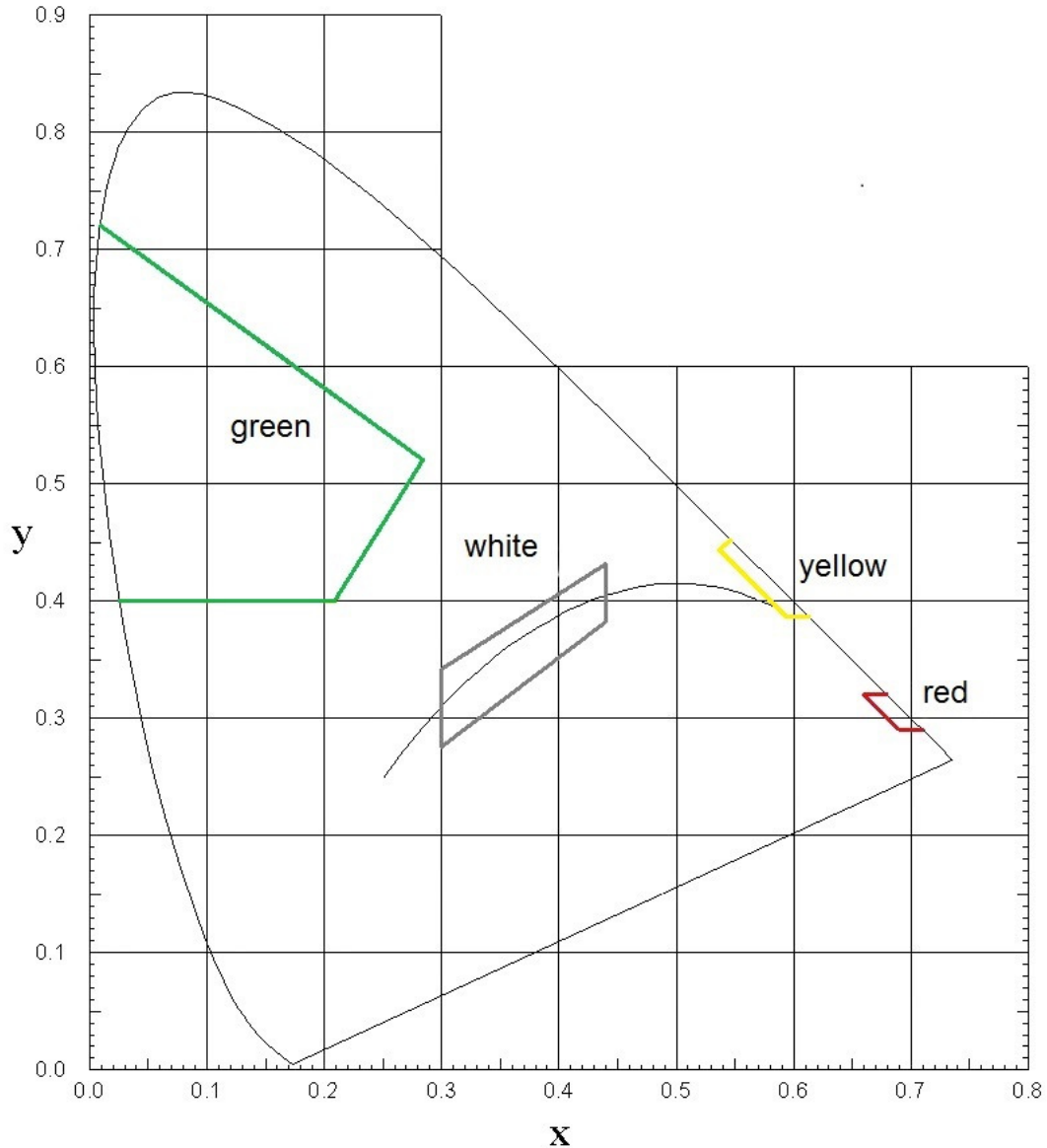

### 3. Calculation of light range

The range of a signal light intended for the guidance of shipping is calculated according to the procedure contained in IALA Recommendation E-200, Part 2 — Calculation, Definition and Notation of Luminous Range, which applies only to signal lights perceived as points by the observer.

Different criteria than those used to establish the range of on-board lights (navigation lights) have been developed for signals intended for the guidance of shipping, which use other values.

The calculations are performed using the following formula:

$$D^2 \times E_t = I_{\text{eff,B}} \times T_M \frac{D}{1852 \text{ m}}$$

Where

$D$  is the range of light;

$I_{\text{eff,B}}$  is the operational luminous intensity of the lantern;

$T_M$  is the value for calculating visibility (describes the atmospheric transmissivity);

$E_t$  is the established limit of luminosity.



The calculation must be done numerically; the formula cannot be solved according to D.

The parameters given are as follows:

$$T_M = 0.6;$$

$$E_t = 2 \cdot 10^{-7} \text{ lx for buoys with lights and simple bank lights with no background lighting;}$$

$$E_t = 10^{-6} \text{ lx to mark a cross-fairway axis with 2 or 3 lights with no background lighting;}$$

$$E_t = 2 \cdot 10^{-6} \text{ lx for all lights with average background lighting (e.g. in a city);}$$

$$E_t = 2 \cdot 10^{-5} \text{ lx for all lights with substantial background light (e.g. industrial facilities).}$$

The operational luminous intensity  $I_{\text{eff,B}}$  is a derivative of the photometric values  $I_{\text{ph}}$  according to the following calculations:

$$I_{\text{eff, B}} = b \times k \times I_{\text{ph}}$$

Where  $b = 0.75$  is the conventionally accepted loss factor owing to dirt and light source degradation.

The effective intensity of rhythmic lights is taken into account by the degree of transmission  $k$ , which is usually calculated according to IALA Recommendation E-200, Part 4 — Determination and Calculation of Effective Intensity.

For the light emitting diodes (LEDs) that are used in most cases and that permit very high frequency commutation, the calculations may be simplified to the following:

$$k = \frac{t}{0,2s + t}$$

Where  $t$  equals the shortest time of light for the rhythm of light used (e.g. 0.5 s for “Fkl. 1s” and 2 sec. for “Glt. 4s”).

**Table 3**

The typical range with visibility  $T_M = 0.6$

<i>Background lighting</i>	<i>No</i>	<i>No</i>	<i>Average</i>	<i>Substantial</i>
<i>Light limit <math>E_t</math> [lx]</i>	$2 \times 10^{-7}$	$10^{-6}$ (marking of the axis)	$2 \times 10^{-6}$	$2 \times 10^{-5}$
<i>Luminous intensity <math>I_{\text{eff,B}}</math> [cd]</i>	<i>Range [m]</i>			
1	1 760	890	650	220
2	2 300	1 200	890	300
5	3 210	1 760	1 320	470
10	4 050	2 300	1 760	650
20	5 010	2 970	2 300	890
50	6 470	4 050	3 210	1 320
100	7 720	5 010	4 050	1 760
200	9 060	6 100	5 010	2 300
500	11 000	9 060	6 470	3 210

### ANNEX 3 COLOURS OF REFLECTED LIGHT FOR NAVIGATION SIGNS

The colours of light reflected by navigation signs (day markings) must conform with CIE publication No. 39-2 (TC-1.6) 1983 “Recommendations for Surface Colours for Visual Signalling”.

The following is taken from the Recommendations:

- Ordinary colours of materials (standard colours), in this case: red, yellow, green, blue, white and black;
- Fluorescent colours of materials (luminescent in daylight), in this case: red, green.

The acceptable colours are given in ranges and with a standard chromaticity diagram, specifying as well the requirements for intensity coefficients (luminance factors). The chromaticity coordinates for the ranges and intensity coefficients are shown in Table 1. For colours adjacent to the spectral colour curve, the curve represents their external limit.

**Table 1**

<i>Colour of the reflected light</i>	<i>Intensity coefficient</i>	<i>1</i>		<i>2</i>		<i>3</i>		<i>4</i>	
<i>Standard colours</i>		<i>x</i>	<i>y</i>	<i>x</i>	<i>y</i>	<i>x</i>	<i>y</i>	<i>x</i>	<i>y</i>
Red	> 0.07	0.690	0.310	0.595	0.315	0.569	0.341	0.655	0.345
Yellow	> 0.45	0.522	0.477	0.470	0.440	0.427	0.483	0.465	0.534
Green	> 0.10	0.313	0.682	0.313	0.453	0.209	0.383	0.013	0.486
Blue	> 0.05	0.078	0.171	0.196	0.250	0.225	0.184	0.137	0.038
White	> 0.75	0.350	0.360	0.300	0.310	0.290	0.320	0.340	0.370
Black	< 0.03	0.385	0.355	0.300	0.270	0.260	0.310	0.345	0.395
<i>Colours luminescent in daylight</i>		<i>x</i>	<i>y</i>	<i>x</i>	<i>y</i>	<i>x</i>	<i>y</i>	<i>x</i>	<i>y</i>
Red	> 0.25	0.690	0.310	0.595	0.315	0.569	0.341	0.655	0.345
Green	> 0.25	0.313	0.682	0.313	0.453	0.209	0.383	0.013	0.486

The figure below shows the admissible colour ranges on the standard chromaticity diagram. The ranges for ordinary colours and those that are luminescent in daylight (red/green) are identical; the colours differ only in their intensity coefficients.

**Figure 1**

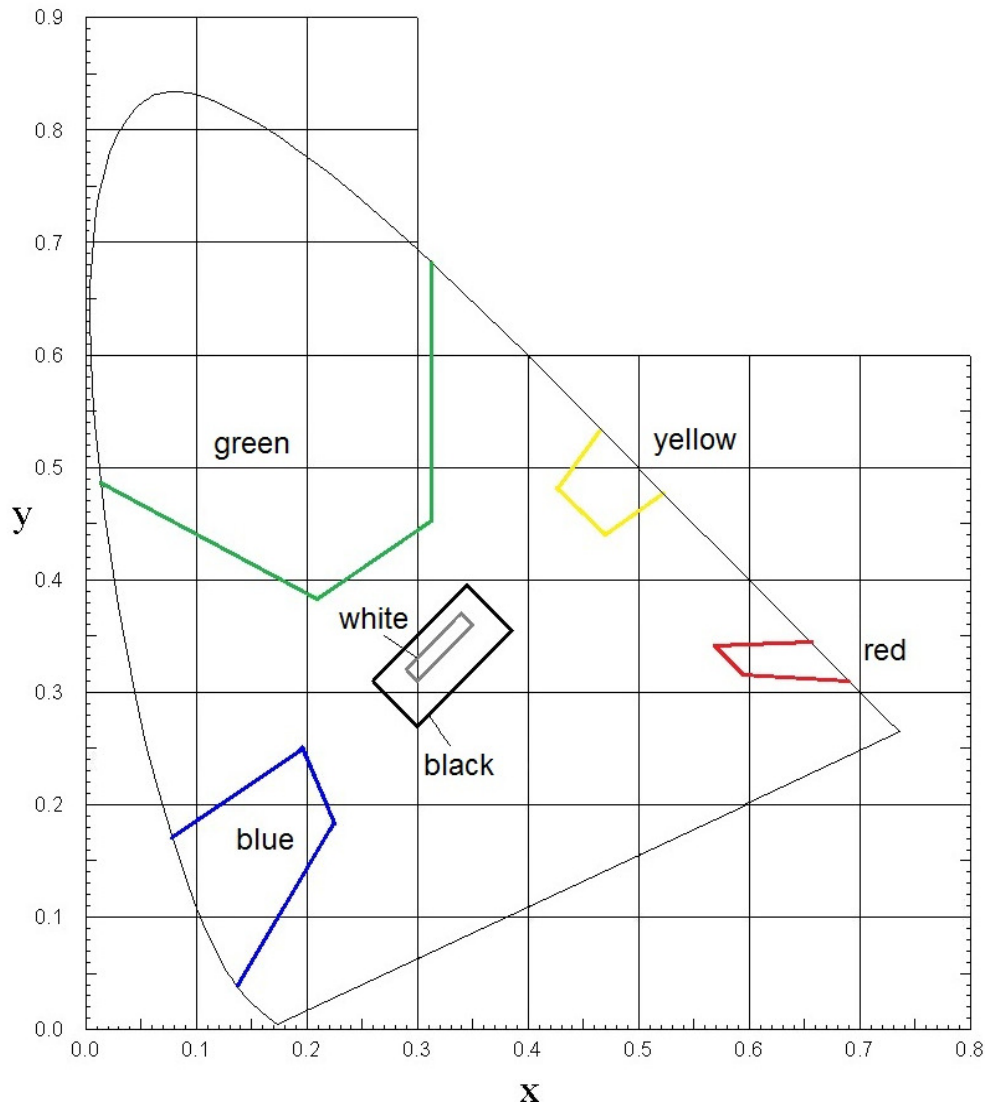

A simplified description of the admissible colours can be presented using the RAL numbers from the internationally recognized RAL-Classic colour system<sup>8</sup>.

The colours below correspond with the CIE Recommendations and are preferred for use in transport technologies.

Table 2

<i>Number</i>	<i>Designation</i>	<i>Recommended use</i>
RAL 1023	Traffic yellow	Traffic signs, buoys
RAL 3020	Traffic red	Traffic signs
RAL 3024	Luminous red	Buoys, strongly visible traffic signs
RAL 3028	Pure red	Buoys, sufficiently visible traffic signs
RAL 5017	Traffic blue	Traffic signs
RAL 6024	Traffic green	Traffic signs
RAL 6037	Pure green	Buoys, sufficiently visible traffic signs
RAL 6038	Luminous green	Buoys, strongly visible traffic signs
RAL 9016	Traffic white	Traffic signs, buoys
RAL 9017	Traffic black	Traffic signs, buoys

It is recommended that navigation sign surfaces, when they are not a part of the signs themselves, should be RAL 7042 traffic grey A or RAL 7043 traffic grey B.

It may be advisable to use adhesive light-reflective films on markers that are not equipped with lights. For the colours of light-reflective films, reference may be made to the relevant international standards for road transport.

## ANNEX 4 RECOMMENDATIONS FOR THE LIGHTING OF TRAFFIC SIGNS<sup>9</sup>

### 1. General provisions

The lighting shall be turned on only at night. During daytime, the sign must be identifiable with natural lighting. The lighting may be arranged either with an external, backward-facing floodlight located in front of the sign or with lighting from the inside of translucent panels (internally backlit signs) as shown in Fig. 1.

**Figure 1**

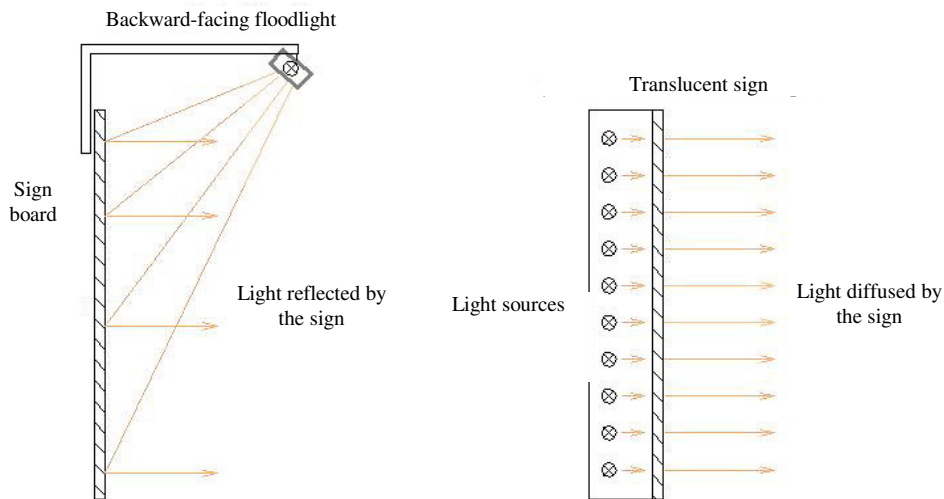

### 2. External backward-facing lighting

External backward-facing lighting from a floodlight located above the sign is generally arranged with floodlights affixed above or below the sign board. For tall signs it is advisable to affix two floodlights (above and below). For wide signs it is possible to affix several floodlights in a line.

To avoid undesirable dark spots and glare, the floodlights must be located in such a way that they do not block a view from an angle of 7 degrees from the horizontal, drawn from the sign's top or bottom edge.

---

<sup>9</sup> This Appendix is based on the provisions of European standard EN 12899-1 "Fixed, vertical road traffic signs". Administrations can apply other international or national standards provided that the same safety level is ensured.

**Figure 2**

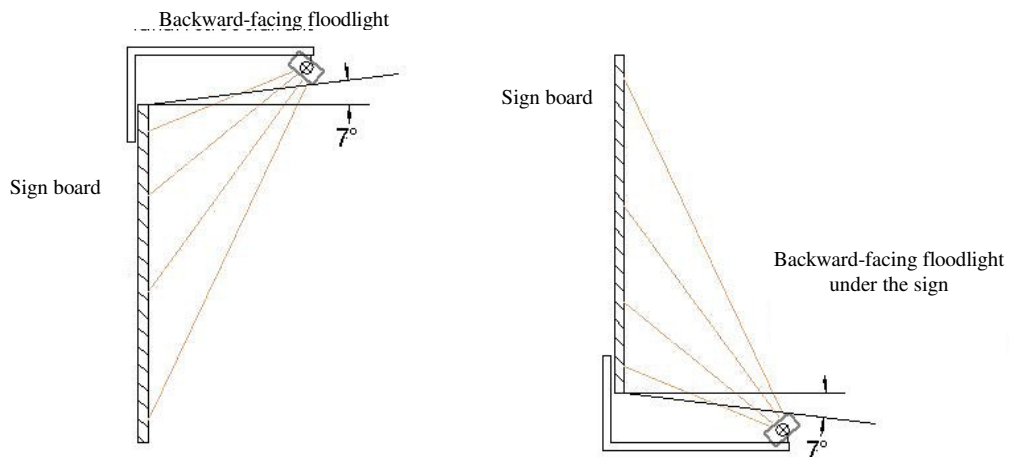

The type of lighting is always determined by the readability of the sign illuminated by the backward-facing light. Minimum dimensions are given in Appendix 1 to these Guidelines.

With some boards, the illuminated surface is identical to the board itself. If several boards conveying a single message are installed, for instance with additional text plates, the lighting requirements refer to the overall surface of the combined boards.

Fig. 3 shows the recommended dimensions of the backward-illuminated surface of a sign board:

- (a) standalone;
- (b) with an additional plate.

**Figure 3**

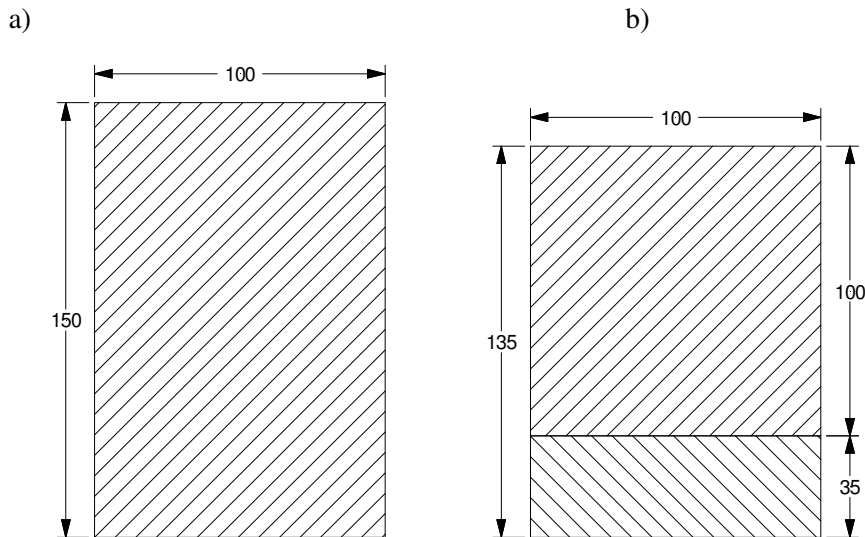

As for the backward-illuminated surface, the following lighting parameters are recommended:

- in areas with insignificant background light levels (for example, outside of city limits), the luminosity measured on-site should range from 40 lx to 100 lx<sup>10</sup>.
- in areas with increased background light levels (for example, within city limits), the luminosity measured on-site should range from 100 lx to 400 lx<sup>11</sup>.

<sup>10</sup> Class E1 of EN 12899.

<sup>11</sup> Class E2 of EN 12899.

The uniformity of lighting is established by the ratio between the minimum luminosity ( $E_{min}$ ) and the maximum luminosity ( $E_{max}$ ) on the back-illuminated surface. In all cases the ratio must be greater than or equal to 1:10 ( $E_{min}:E_{max} \geq 1:10$ )<sup>12</sup>.

For the lighting, a white lamp with a colour temperature between 3500 K and 4500 K is used. Care must be taken to ensure that the sign colours are reproduced when the backward-facing light is white.

### **3. Internally backlit signs**

It is recommended to use intensity class L113 for signs in areas with insignificant background light and intensity class L2 for those with increased background light levels.

As for the uniformity of the lighting, the aim should be to reach class U1 (1:10).

---

12 Class UE1 of EN 12899.

13 In this paragraph the reference is made to intensity and uniformity classes in EN 12899.

## ANNEX 5 EXAMPLES FOR VARIABLE-MESSAGE TRAFFIC SIGNS<sup>14</sup>

### 1. Mechanical boards

#### A. Scrolling sign boards

Boards with a scrolled band of sign images are useful as variable message traffic signs, in particular for displaying the signs in annex 7 to CEVNI.

The sign images are placed on a band that is scrolled vertically on rollers. The rollers place the currently valid image in the window for display.

**Figure 1**

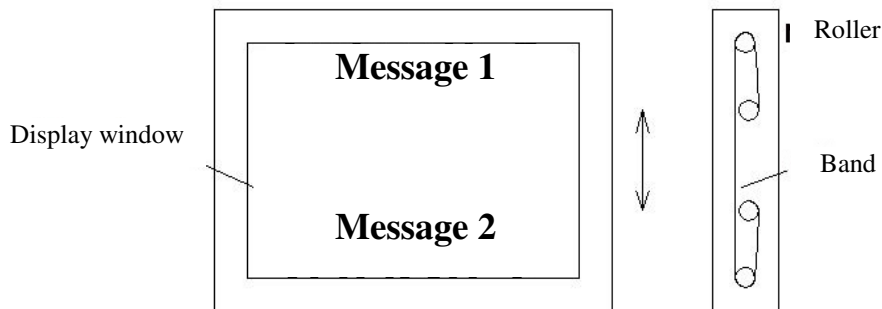

The advantage of scrolling sign boards is that they make it possible to display a large number of signs.

For numerical displays (water levels, cross currents), each digit is displayed using a pile of split flaps capable of representing the numbers from 0 to 9.

#### B. Trivivon boards

Trilon boards are used preferably to display two different signs from annex 7 to CEVNI. This technique is limited to displaying three distinct sign images. Generally, the third position is reserved as blank, with a gray surface.

**Figure 3**

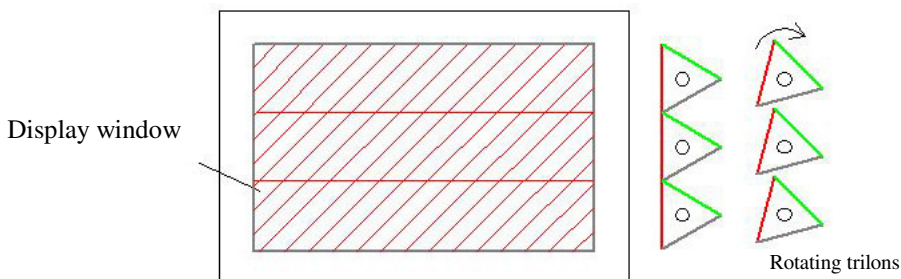

In comparison with boards using scrolling bands, the advantage of trilons is that they are mechanically more robust. At the same time, it is not necessary to produce sign images on a flexible surface, which makes it possible to use paints and films of proven value for use on navigation signs.

#### C. Other mechanical boards

There are many mechanical systems for information boards (for example, including flip-disk boards), with many designed for use in indoor spaces (such as transport terminals or stations). For navigation signs, which generally

---

<sup>14</sup> This Appendix is based on the provisions of European standard EN 12966-1 “Vertical road signs — Part 1: Variable message signs”. Administrations can apply other international or national standards provided that the same safety level is ensured.



have to bear the brunt of weather conditions, the service life of such systems is often negligible; they often require servicing.

## 2. Electronic boards

Purely electronic systems for information boards have the basic advantage of incorporating absolutely no moving parts. The ones that are best known are boards using LEDs, liquid crystals or optical fibres.

Such messages are displayed as white or yellow digits or letters on a black background.

During manufacture, the characters are converted into groups of constituent dots to ensure that they can be read.

While mechanical boards are visible with natural light during daylight hours, electronic boards emit light both day and night.

At the same time, a contrasting frame is required, the aim being to reduce the so-called phantom effects caused by sunlight. Reflection angles must be sufficiently large to reliably eliminate reflections on the fairway segments in question.

As a direct consequence, electronic boards consume significantly more energy than mechanical ones.

At the same time, in daylight, the boards must be sufficiently luminous so that their messages can be seen even in clear and sunny weather. At night, they must be darkened so as to avoid unwanted brightness or dazzle.

Adjustments are made by measuring the background luminous intensity and adapting the intensity of the board accordingly<sup>15</sup>.

The boards' reflection angles should also be observed<sup>16</sup>.

For horizontally illuminated sectors there are classes with ranges up to  $\pm 30^\circ$  ( $60^\circ$ ). Technically, it is possible to display sectors ranging up to  $\pm 60^\circ$  ( $120^\circ$ ) at an acceptable cost.

### A. Optical waveguide (optical fibre) boards

Optical fibre boards have been used for many years on variable message road traffic signs (for example, to display temporary speed limits). The sign's image is divided into distinct points of light, with each point backlit by an optical fibre.

When a digit is displayed, the optical fibres of the digit in question are grouped and backlit with a lamp. For each digit there is thus a separate lamp, and each point of light can be used for just one digit. The points thus cannot be individually controlled. Each image must in turn have a source lamp.

#### Figure 3

Depiction of light points corresponding with lamps for two digits (for clarity, only some of the optical fibres are shown)

---

<sup>15</sup> If standard EN 12966-1 is used for this purpose, the adjustment coefficient (the board's maximum-to-minimum luminosity ratio) exceeding 100:1 is applied.

<sup>16</sup> The luminance classes described in standard EN 12966-1 are intended for road traffic and would presuppose that the boards are installed at least as high as the maximum height of a bridge allowing for navigation.

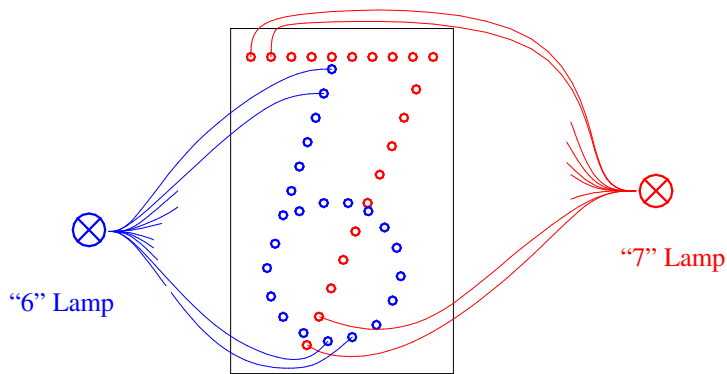

In recent years, optical fibre boards have to a great extent been replaced by LED matrix boards.

**B. Light-emitting diode (LED) matrix boards**

In the case of a LED matrix, each separate point of the image is displayed by a diode that can be independently turned on and off. In principle, such boards can be freely programmed (using a complete matrix), thus making it possible to display any message.

**Figure 4**  
Individually controlled light emitting diodes displaying digits

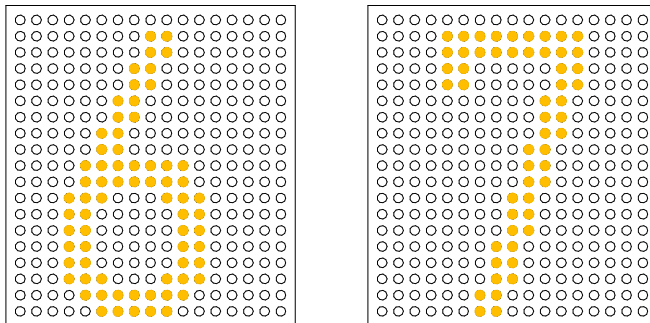

Often, though, only seven segments required to display digits are connected.

As fewer diodes are used, the electronic control is simplified, which results in savings. To reduce costs, it is possible to pre-programme groups of LEDs to display only the messages that are required.

**Figure 5**

Board composed of seven segments with separate light emitting diodes

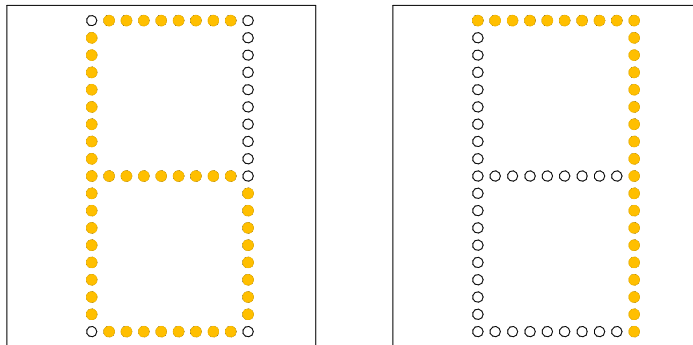

**C. Liquid crystal displays (LCDs)**

Boards using liquid crystal displays (LCDs) are composed of a regularly illuminated surface placed behind a film of liquid crystals, which blocks areas of the image, thus creating the desired figure. For large boards, monochrome images are preferred, although colour images are possible as well. Diodes have recently been employed to backlight the surface, while fluorescent lamps were previously used.

The advantage of this kind of board is that it produces a very sharp, detailed image, with such high luminosity and contrast that the boards can be used in daylight.

There is a technical disadvantage, though, as the optical characteristics of the liquid crystal film are such that only a small part (less than 25 per cent) of the generated light is displayed. For the same luminosity, boards of this kind require significantly more power than those using LED matrices.

What is more, because liquid crystal displays are extremely sensitive to temperature changes and humidity, they must be protected, which involves high costs.





**AMENDMENTS TO THE DECISION 15/14 ON  
THE RULES FOR THE WATERWAY  
MARKING IN THE SAVA RIVER BASIN**

## I AMENDMENTS TO THE CHAPTER 1 “GENERAL”

1. Amendments to the Article 1.1
  - a) Amend the indent (b) as follows: “Signs and signals installed on the waterway (hereafter **floating signs**) and signs installed on the banks (hereafter **bank marks**) marking the sides of the fairway and navigational hazards, set out in Annex 8 to the Navigation Rules in the Sava River Basin.”
2. Amendments to the Article 1.3
  - a) Replace the term “**boatmen**” with the following phrase “**vessels’ crew members**”
3. Amendments to the Article 1.4
  - a) Replace the sentence of the article “The signs and signals on the water and bank marks of Annex 8 to the Navigation Rules in the Sava River Basin are used to indicate the limits, the direction and the depth of the fairway and, in addition, are used to mark obstacles and permanent structures on the fairway or its vicinity.” with the following one “**Floating signs** and bank marks of Annex 8 to the Navigation Rules **in** the Sava River Basin are used to indicate the limits, the direction and the depth of the fairway and, in addition, to mark obstacles and structures protruding into the fairway or in its vicinity.”
  - b) Add a new sentence: “Here, the instructions of Section A of Chapter I, 8 to the Navigation Rules **in** the Sava River Basin shall be taken into account.”
4. Amendments to the Article 1.5
  - a) Replace the sentence of the article “The number of bank marks and signs and signals on the water and the plan for their on site location shall meet the requirements of navigational safety.” with the following one “The number of **signs**, bank marks, **floating signs and their on-site locations** shall meet the requirements of navigational safety ”
5. Amendments to the Article 1.6
  - a) In the first sentence replace the term “waterway” with “fairway”,
  - b) Replace the second sentence of the article “Their installation shall be effected in such a way as to ensure visibility from one mark to the next.” with the following one “Their installation shall be effected in cases **when it is required by navigation criteria on the respective river section**, in such a way as to ensure visibility from one mark to the next.”
6. Amendments to the Article 1.7
  - a) Replace the second sentence of the article “In calculating the luminous range, the atmospheric transmission coefficient 0.6 should be used over a distance of 1 nautical mile.” with the following one “In classifying the luminous intensity, it is recommended to use the classification of luminous intensity in annex 2 to the present Rules, which also includes calculations for luminous range.”
7. Amendment to the Article 1.8
  - a) Replace the sentence “ In principle, the colours of lights should be kept with the recommendations of the International Commission on Illumination (“Colours of light signals”, in ICI publication No. 2.2 (T.C. 1.6) 1975).” with the following one “In principle, the colours of lights should be in keeping with the

**standard** of the International Commission on Illumination (“Colours of light signals”, **CIE S 004/E-2001, class A**”).

8. Amendments to the Article 1.9

- a) In the indent (a) replace the term “bed of the river” with “river bed”,
- b) In the indent (c) replace the sentence “Establish the plan for installation of signs and marks in their respective sectors and establish the type and number of signs and signals on the water and bank marks to be used, in terms of the requirements of navigational safety and local conditions” with the following one “Establish the plan for the installation of signs and marks (**hereinafter the marking plan**) in their respective sectors and establish the type and number of **floating** signs and bank marks to be used, in terms of the requirements of navigational safety and local conditions”,
- c) In the indent (d) replace the sentence “Ensure the uninterrupted operation of all signs and signals on the water and bank marks” with the following one “Ensure **as far as possible** the uninterrupted operation of all **floating** signs and bank marks”,
- d) In the indent (e) replace the sentence “Timely inform the boatmasters of the date of the installation and removal of signs and signals, of all alterations to their number, type, positioning and lighting, and the rules they establish permitting the passage of vessels in restricted sections where meeting and passing are prohibited” with the following one “Inform boatmasters in good time of the date of the installation and removal of signs of all alterations **of importance to navigation** to their number, type, positioning and lighting, and the rules they establish permitting the passage of vessels in restricted sections where meeting and passing are prohibited.”

## II AMENDMENTS TO THE CHAPTER 2

9. Amendment to the Title
  - a) Rename the title of the chapter as follows: „**REQUIREMENTS TO BE MET BY SIGNS AND MARKS AND THEIR MARKING PLAN**“;
10. Amendments to the Article 2.1
  - a) Replace the first sentence “Marking shall be continuously (by day and night) in operation all along the navigable section of the river, as of the waterway is free from ice until the ice appears; it shall be corrected as changes occur in the waterlevel and in the fairway.” with the following one “**The** marking shall be in operation continuously (by day and by night) all along the navigable section of the river, **and, as far as possible**, as **from** when the waterway is free from ice until the ice appears; it shall be corrected as changes occur in the water level and in the fairway.”
11. Amendments to the Article 2.2
  - a) Replace the word “**marking**” with a term “**floating signs**”,
12. Amendments to the Article 2.3
  - a) Delete the whole article.
13. Amendments to the Article 2.4
  - a) Renumber the article to “Article 2.3”.
  - b) Replace the phrase “Signs and signals on the water” with a term “**floating signs**”,
14. Amendments to the Article 2.5
  - a) Renumber the article to “Article 2.4”.
15. Amendments to the Article 2.6
  - a) Renumber the article to “Article 2.5”.
  - b) Replace the phrase “plan for the installation of the signs and marks” with a term “**marking plan**”,
16. Amendments to the Article 2.7
  - a) Renumber the article to “Article 2.6”.
  - b) In the first sentence replace the phrase “plan for the installation of the signs and marks” with a term “**marking plan**”,
  - c) In the first sentence replace the phrase “Signs and signals on the water” with a term “**floating signs**”,
  - d) Add clause: “and, where necessary, of seagoing vessels” at the end of the second sentence.
17. Amendments to the Article 2.8
  - a) Renumber the article to “Article 2.7”.

- b) In the second sentence replace the term “Signs and signals on the water” with “**Floating signs**” at the beginning of the sentence.
- c) In the second sentence replace the term “used whilst marking” with “used **for** marking”

18. Amendments to the Article 2.9

- a) Renumber the article to “Article 2.8”.
- b) In the first sentence replace the phrase “plan for the installation of the signs and marks” with a term “**marking plan**”,
- c) In the indent (e) replace the term “**signs and signals on the water**” with “**floating signs**”.

19. Amendments to the Article 2.10

- a) Renumber the article to “Article 2.9”.

20. Amendments to the Article 2.11

- a) Renumber the article to “Article 2.10”.



### III AMENDMENTS TO THE CHAPTER 3

21. Amendments to the Article 3.1
- a) In the second sentence delete words “**and signals**”
22. Move the subtitle “**Conditions of visibility and dimensions of signs**” before the Article 3.7 instead of the Article 3.4
23. Amendments to the Article 3.5
- a) Replace the first sentence “There are three degrees of visibility of signs and signals:” with the following one “**In accordance with the recommendations of the International Association of Marine Aids to Navigation and Lighthouse Authorities (IALA), there are three degrees of visibility of signs and signals:**”
  - b) In the indent (a) replace the sentence “When, because of the distance, the sign is no more than a blotch on the background and neither shape nor colour can be distinguished (dotted outline)” with the following one “**First: the sign is visible to the naked eye.**”
  - c) Add a new sentence to the indent (a): “**The meaning of the sign is not yet identifiable (simply visible)**”;
  - d) In the indent (b) replace the sentence “When the sign is visible and its shape and outline can be seen, but the colour remains unclear;” with the following one “**Second: when the sign is clearly visible and identifiable according to Navigation Rules in the Sava River Basin (identifiable)**”.
  - e) In the indent (c) replace the sentence “When the shape and colour of the sign can be seen distinctly.” with the following one “**Third: the sign is identifiable and distinguishable from its surrounding background (conspicuous).**”
  - f) Replace the sentence “Marks that must be observed at certain distance by the shipmaster of (“danger”, “no passing”) must be of the visibility (relative to their exact dimensions) of the second and third degree. ” with the following one “Signs that must be seen by a boatmaster at some imperative distance (“no entry”, “keep a particular sharp lookout”, etc.) must be of the visibility (due to their proper dimensions) of second or third degree.”
  - g) Replace the sentence “The type and the size of marks should be chosen accordingly ” with the following one “The type and dimensions of signs should be selected accordingly.”
  - h) Add a new paragraph at the end of the article: “**Third degree visibility is required when the sign or light is identifiable in principle, but cannot be easily seen at night owing to the surrounding background (presence of construction or a large number of light sources).**”
24. Amendments to the Article 3.6
- a) Replace the first sentence “The degree of visibility of a sign, as of any object, depends primarily on the size of the viewing angle, the colour contrast, the contrast in luminance and weather conditions.” with the following one “The degree of visibility of signs **and lights**, depends **on the following conditions:**”
  - b) Add new bullets:
    - Signs:
      - Angle of sight;
      - Colour contrast and differences;
      - Lighting (including natural day light) and weather conditions.

Lights:

- Luminous intensity;
- Competing lights and background lighting;
- Weather conditions.

25. Amendments to the Article 3.7

- a) Replace the first sentence “In order to ensure the visibility of first degree, it is necessary to see the sign under  $\theta$  angle by day and under  $10^\theta$  angle by night. ” with the following one “In order to ensure the **first degree** visibility, **in daytime** the sign shall be visible with an angle **of more than 1 angular minute and with sufficient contrast in relation to the environment.**”
- b) Replace the second sentence “Detailed form and colour of the sign (visibility of second and third degree) are identified even under larger angles.” with the following one “Detailed form and colour of the sign (second and third degree **visibility**) **can only be distinguished with a larger angle of sight or with a reduction in the distance  $L$  to the object being observed.**”

26. Amendments to the Article 3.8

- a) Replace the first sentence “The largest angle of distinction by day for simple shapes (quadrant, triangle, circle, etc.) shall be within  $3.5^\theta - 5^\theta$  scale, and for complex shapes (numbers, letters, etc.) within  $5' - 8'$  scale.” with the following one “The **minimal** angle of distinction **in daytime** for simple shapes (**cylinder, cone, sphere** etc.) **is between 3 and 5 angular minutes**, and for complex shapes (numbers, letters, etc.) **between 5 and 8 angular minutes.**”
- b) Replace the second sentence “For boatmaster to be able to recognize (without any optical aids) shape of the sign at appropriate distances and visibility, the above-mentioned implies that following formula can be used for calculation of the sign’ dimension:” with the following one “For the boatmaster to be able to recognize **the daymark** (without any optical aids) at appropriate distances and visibility, the following formula can be used for the calculation of the **required minimum dimensions of simple and complex shapes:**”
- c) Replace the symbol “ $\theta$ ” with the following one “ $'$ ” in the whole article (*angular minutes instead of angular degrees*)
- d) Replace the Table 1 with the following one

For signs of simple shapes (quadrant, triangle, circle, etc.)	L(m) \ $\alpha$ ( $'$ )	500	1000	2000	3000	4000
	3	0.44	0.87	1.74	2.61	3.48
4	0.58	1.16	2.32	3.48	4.64	
5	0.73	1.45	2.90	4.35	5.80	

27. Amendments to the Article 3.9

- a) Replace the first sentence “Examples of the minimum measurements for the signs, are given in the Annex to these Rules.” with the following one “Examples of the minimum measurements for the signs, **marks and buoys from Annexes 7 and 8 to Navigation Rules on the Sava River Basin are given in Appendix 1 to these guidelines.**”
- b) In the first paragraph replace the term “various traffic signs” with “various signs” (delete traffic)

- c) In the third paragraph replace the first sentence “For bank marks and signs, minimal height of the lower rim of board down to the ground shall be 3 m.” with the following one “For bank marks and signs, **the** minimal height from the lower rim of the board down to the **base of the lowest sign** shall be 3 m.”
  - d) In the third paragraph replace the second sentence “At high water-levels highest navigation waterlevels, height of the water level up to the lower rim of board should not be less than 1.5 m" with the following one “At highest navigation water levels, the height **between the water surface** and the lower rim of the board **of the lowest sign** should not be less than 1.5 m.”
28. Amendments to the Article 3.10
- a) In the last sentence delete “or material” (at the end of the sentence)
29. Amendments to the Article 3.12
- a) In the first sentence replace the term “signs and signals” with “signs” at the end of the sentence (delete the term “and signals”).
30. Amendments to the Article 3.13
- a) In the first sentence replace the term “signs and signals” with “signs”.
31. Amendments to the Article 3.14
- a) Replace the term the hole article with the following one:  
 “In order to guarantee the visibility of lighted boards, the back lighting must conform with the provisions of annex 4, where, in addition to luminance and its regularity, the colour for the white light source is established to ensure that colours under artificial light look the same as when seen in daylight.  
 For reliable identification at night the surface of the sign must be smooth and even, and if possible reflective.”
32. Amendments to the Article 3.15
- a) Replace the term “marks” with “markings”.
33. Amendments to the Article 3.16
- a) Replace the sentence “It is recommended that the luminous intensity of a light should be determined according to Directive 2006/87/EC " with the following one “**Luminous intensity is broken down into three categories in terms of navigation lights for inland waterway vessels (see appendix 2 to the present Guidelines)**”.
34. Amendments to the Article 3.17
- a) Replace the whole article (including the table) with the following one “**Light signals are identified according to their characteristics. The characteristics are given by their colour and the rhythmicity the light source in accordance with annex 8 to Navigation Rules on the Sava River Basin**”.

35. Amendments to the Article 3.18

- a) Replace the whole article (including the table) with the following one “**Signs and marking shall be installed in such a way that their lights do not hinder the movements of other modes of transport if the road runs close to the river**”.

36. Amendments to the Article 3.19

- a) Replace the whole article (including the table) with the following one “**In a sector in which a road or a railway runs close to a river, the installation of all the above-mentioned signs and signals shall be carried out in consultation with the respective competent authorities**”.

#### IV AMENDMENTS TO THE CHAPTER 4

37. Amendments to the Article 4.1.4
- a) Replace the term “sign or signal on the water ” with the “**floating sign**”.
  - b) Replace the term “bed” with the “**river bed**”.
38. Amendments to the Article 4.1.5
- a) In the first sentence replace the term “sign or signal on the water ” with the “**floating sign**”
  - b) In the first sentence replace the term “marking installation plan” with “**marking plan**”. (delete the word “installation”)
39. Amendments to the Article 4.1.6
- a) In the first sentence, replace the term “floating signs and signals” with the “**floating signs**” (delete “and signals”).
  - b) In the first sentence delete the phrase “**on the water**”
  - c) Replace the second sentence “If the current flows in the direction of an obstacle, the sign or signal shall always be placed a long way from the navigational hazard (obstacle); if, on the other hand, it flows in the opposite direction, the sign or signal shall be placed nearer” with the following one “If the current flows in the direction of a **navigational hazard** (obstacle), the sign or signal shall always be placed a long way from **it**; if, on the other hand, it flows in the opposite direction, the sign or signal shall be placed nearer.,
40. Amendments to the Article 4.1.7
- a) Replace the term “floating signs and signals on the water” with the “**floating signs**” (delete “or signals on the water”).
41. Amendments to the Article 4.1.8
- a) Replace the term “alluvial fairways” with the “**in meandering sectors**”.
42. Amendments to the Article 4.1.11
- a) In the first sentence replace the term “centerline of the fairway,” with the “**axis of the fairway**”.
  - b) In the first sentence replace the term “bank lights,” with the “**bank marks and lights**”. (u UNECE document “**bank signs and lights**”)
  - c) In the second sentence replace the term “signs or signals on the water ” with the “**floating signs**”.
43. Amendments to the Article 4.1.12
- a) Replace the term “fairway” with the “**river bed**”.
  - b) Replace the term “marks on the banks,” with the “**bank marks**”.
44. Amendments to the Article 4.1.13
- a) Replace the term “sign or signal on the bank” with the “**bank mark**”.

45. Amendments to the Article 4.1.15
- a) Replace the term “sign or signal on the bank” with the “**bank mark**”.
46. Amendments to the Article 4.1.17
- a) Replace the term “signs or signals on the bank” with the “**bank marks**”.
  - b) Replace the term “signs or signals on the water ” with the “**floating signs**”.
- (Replace the sentence as follows “As a general rule, the objective is that only the network of **bank marks** shall provide an uninterrupted indication of the position of the fairway as a whole, while the **floating signs** shall help boatmasters to determine the limits of the fairway.”)
47. Amendments to the Section 4.2
- a) Amend the title of the section as follows “**Marking of meandering sectors**”.
48. Amendments to the title of Article 4.2.1
- a) Replace the term “cross- channel fairway signs ” with the “**cross-over marks**”.
49. Amendments to the Article 4.2.1.2
- a) Replace the sentence “Alluvial channels are marked by bank lights and cross-channel fairway signs when the fairway is sufficiently broad, its safety is ensured, and when the direction only requires to be indicated approximately.” with the following one “**Cross-over marks and bank lights are placed** when the fairway is sufficiently broad, its safety is ensured, and when the direction only requires to be indicated approximately.”
50. Amendments to the Article 4.2.1.3
- a) Replace the term “cross- channel fairway signs ” with the “**cross-over marks**”.
  - b) Replace the term “cross-channel fairways” with the “**cross-overs**”.
51. Amendments to the Article 4.2.1.4
- a) In the first sentence replace the term “cross- channel fairway signs ” with the “**cross-over marks**”,
  - b) In the second sentence replace the term “signs on the water ” with the “**floating signs**”,
  - c) In the second sentence replace the term “when the disposable width” with the “**where the available width**”,
  - d) In the second sentence replace the term “two times bigger” with the “**two times wider**”,
  - e) In the third sentence replace the term “double width” with the “**minimum prescribed width**”,
  - f) In the third sentence replace the term “signs on the water ” with the “**floating signs**”,
  - g) In the third sentence replace the term “disposable width ” with the “**the available width for navigation**”
52. Amendments to the Article 4.2.1.5
- a) Replace the first sentence “If distance between two neighbouring cross-channel fairway signs is larger than calculated visibility, and when navigation line is passing nearby the bank, the bank lighted sign,

which additionally marks the position of the navigation line, is placed between those two neighbouring cross-channel fairway signs (Figure 2, sign a).” with the following one “If the distance between two neighbouring cross-**over marks** is larger than the calculated visibility, and when the **fairway** passes **close to** the bank, the **bank mark with light**, which additionally marks the position of the **fairway**, is placed between those two neighbouring **cross-over marks** (Fig. 2, sign a).”

- b) In the second sentence replace term “bank lighted sign” with “**bank mark with light**”.

53. Amendments to the Article 4.2.1.6

- a) Replace the sentence “In case when the direction of the current makes the angle with fairway, when strong side winds or something alike occur, fairway can be additionally marked by navigation marks according to the local conditions (Figure 3)” with the following one “In case when the direction of the current makes the angle with fairway, when strong side winds or **similar situations** occurs, **the** fairway can be marked by **additional** navigation marks according to the local conditions (Figure 3)”

54. Amendments to the Article 4.2.1.7

- a) Replace the sentence in the first paragraph “If the fairway at longer transitions goes through the river centre or stingingly crosses from one to another bank, then two cross-channel fairway signs on each side of the fairway, which better mark the transition, can be placed.” with the following one “**When** the fairway at longer transitions goes through the **middle of the river bed** or **sharply** crosses from one bank to another, its axis may be indicated by a **pair of cross-over marks on each side of the fairway**, as shown in Figure 4”.
- b) Replace the first sentence in the second paragraph “The advantage is given to cross- channel fairway signs on each side of the fairway in case of straight-line sections longer than 5 km, where disposable width is less than double width of the fairway ” with the following one “The advantage is given to cross-**over marks** on each side of the fairway in case of straight-line sections longer than 5 km, where **available width for navigation** is less than double **the** width of the **minimum presribed width of the fairway for a particular sector.**”.
- c) Replace the second sentence in the second paragraph “In that case and when the bank configuration allows so, the cross- channel fairway signs are placed on both margins of transition (Figure 4)” with the following one “In that case and when the bank configuration allows so, the **cross-over marks** are placed on both margins of transition (Figure 4).”.
- d) Replace the sentence in the third paragraph “Cross-channel fairway signs on each side of the fairway are also placed when certain obstacles to navigation or other hazards narrowing the fairway occur.” with the following one “**It is always preferable to have two cross-over marks** on each side of the **fairway when the fairway is narrowed by certain obstacles constituting threats to navigation or other hazards marked by floating signs**”.

55. Amendments to the Article 4.2.1.8

- a) Replace the first sentence “On section where the navigation line re-crosses to the opposite bank immediately after transition to the opposite bank, three cross-channel fairway signs (the front should have two boards) are mandatory placed (Figure 5)” with the following one “On a section where the **fairway returns** to the opposite bank immediately after **crossing the waterway**, three cross-channel fairway signs (the front should have two boards) are mandatorily placed (Fig. 5).”
- b) Replace the second sentence “In that case, lights of the back cross- signs channel fairway signs should shall be strictly directed to the fairway axis: one to upstream and other one to downstream.” with the following one “In that case, lights of the back cross-**over marks** shall be **oriented** strictly **on the axis of the** fairway: one upstream and other downstream.”

56. Amendments to the Article 4.2.1.9
- a) Replace the term “back sign” with the “**back mark**” wherever in the article.
  - b) In the bullet related to L (m) replace the term “cross channel fairway signs ” with the “**cross-over marks**”.
  - c) In the bullet related to a (m) replace the term “cross channel fairway” with the “**cross-over**”.
  - d) In the bullet related to h0 (m) replace the term “sign” with the “**mark**”.
  - e) Replace the sentence related to the Table 3 with the following one “Table 3 **also assumes** that the observer’ sight is 5m above the water level, and light of the lower (front) sign is 8m above the water level ”.
  - f) In the second but last sentence replace the term “channel fairway signs ” with the “cross-over marks.
  - g) Replace the last sentence “Due to good recognition of cross-channel fairway signs and their lights by night, the viewing angle  $\alpha$  (') cannot be less than 4'.”with the following one ” **To ensure proper recognition of cross-over marks** and their lights, the viewing angle  $\alpha$  cannot be less than 4 **angular minutes in relation to the vertical.**”
57. Amendments to the Subsection 4.2.2
- a) Amend the title of the subsection as follows “**Installation of floating signs**”.
58. Amendments to the Article 4.2.2.1
- a) In the first paragraph replace the term “sectors of alluvial channels” with “**meandering sectors**”.
  - b) In the first paragraph replace the term “signs and signals on the water ” with the “**floating signs**”,
  - c) Replace the first sentence of the second paragraph “These underwater obstacles are marked in sectors of alluvial fairways by signs and signals on the water if, within the limits of width indicated above, the depth of water over such obstacles does not exceed the minimum depth reported for the sector.” with the following one ”These underwater obstacles are marked in **meandering** sectors by **floating** signs if, within the limits of width indicated above, the depth of water over such obstacles does not exceed the minimum depth reported for the sector.”
  - d) Replace the second sentence of the second paragraph “If the obstacle is not very wide a light signal shall be installed on the water on its upstream section.” with the following one ”If the obstacle is not very wide a **floating sign with light** shall be installed on its upstream section.”
59. Amendments to the Article 4.2.2.2
- a) Replace the term “Signs and signals on the water ” with the “**Floating signs**”
60. Amendments to the Article 4.2.2.3
- a) Replace the sentence “In parts of the river bed where the shore opposite of the other one followed by the fairway is bordered by an inshore bank, which favours upstream navigation in calm water, the bank is marked by signs and signals on the water independently of the width of the bed.” with the following one “In parts of the river bed where the shore opposite **that** followed by the fairway is bordered by an inshore bank, which favours upstream navigation in calm water, the bank is marked by **floating** signs independently of the width of the **river** bed”,
61. Amendments to the Article 4.2.2.4
- b) Replace the term “sectors of alluvial channels,” with the “**meandering sectors**”



62. Amendments to the Section 4.3
- a) Amend the title of the section as follows “**Marking of shoals**”.
63. Amendments to the Article 4.3.1
- a) Replace the first sentence “Same principle, as to other sections, according to which set of marks must ensure continuous marking of the fairway, shall apply to shallow water.” with the following one ” **In shoals, as in other sections, the principle of the continuous marking of the direction of the fairway shall be applied.**”
  - b) In the second sentence replace the term “shallow waters” with the “**shoals the fairway**”
  - c) In the second sentence replace the term “cross- channel fairway signs” with the “**cross-over marks**”
  - d) In the second sentence replace the term “signs and signals on the water” with the “**floating signs**”,
64. Amendments to the Article 4.3.2
- a) Replace the term “placed” with the “**located**”
  - b) Replace the term “shallow waters” with the “**shoals**”
  - c) Replace the term “channel fairway signs ” with the “**cross-over marks**”
  - d) Replace the term “disposable width ” with the “**available width for navigation**”
65. Amendments to the Article 4.3.3
- a) Replace the term “shallow waters” with the “**shoals**”,
  - b) Replace the term “floating signs and signals” with the “**floating signs**”,
66. Amendments to the Article 4.3.4
- a) Replace the sentence “If the fairway is passing between sandbars, which get deeply into the riverbed, in straight-line, it’s necessary to place at least two signs on the water on the entry and exit of such section: one on the top of the upstream and other one on the top of the downstream sandbar (Figure 10).” with the following one ” If the fairway passes **in a straight line** between sandbars, **reaching far into the river bed**, it is necessary to place at least two **floating signs at** the entry and the exit of such a section: one at the top of the upstream and one on the top of the downstream sandbar (Fig. 10).”
67. Amendments to the Article 4.3.5
- a) Replace the term “floating signs on the water” with the “**floating signs**”
68. Amendments to the Article 4.3.6
- b) Replace the term “floating signs on the water” with the “**floating signs**”
69. Amendments to the Article 4.3.7
- a) Replace the sentence “In case when application of cross-channel fairway signs is impossible, the fairway may be marked by signs or signals on the water, on one or both sides, depending on width of the fairway and hydrological conditions.” with the following one ”In case **the** application of **cross-over marks** is

impossible, the fairway **across a shoal** may be marked only by **floating** signs, on one or both sides, depending on the width of the fairway and hydrological conditions.”

70. Amendments to the Article 4.4.2
- a) Replace the term “floating signs and signals on the water and on the banks” with the “**floating signs and bank marks**”
71. Amendments to the Article 4.4.3
- a) Replace the term “signs” with the “**marking signs**”
72. Amendments to the Article 4.4.5
- a) Replace the sentence “Signs and signals may be installed on the water at the approach to the navigable passage to give an exact indication of the position of the fairway.” with the following one “**Floating** signs may be installed at the approach to the navigable passage to give an exact indication of the position of the fairway.”
73. Amendments to the Article 4.4.6
- b) Replace the first sentence “Examples of placement of the mentioned signs on the water or bank marks marking the section nearby the bridges:” with the following one “**The following** examples **show the** placement of the aforementioned signs marking the section near bridges:”
  - c) In the bullet (a) replace the term “by signs on the river banks” with the “by **bank marks**”
  - d) In the bullet (b) replace the term “floating signs on the water” with the “**floating signs**”
  - e) In the bullet (c) replace the term “fairway axis” with the “**axis of the navigable passage**”
  - f) In the bullet (c) replace the second sentence as follows: “One pair of buoys closer is placed at distance of 100m - 200m upstream of the bridge, and second pair, 400m - 700m upstream of bridge”.
  - g) In the bullet (c) replace the sentence “Buoys more distant from the bridge are placed in order to follow the river flow jointly with the closer pair of buoys.” with the following one “Buoys **further away** from the bridge are placed in **such a way that in combination with the pair of buoys close the bridge, they mark the river flow**”.
74. Amendments to the Section 4.5
- a) Amend the title of the section as follows “**Installation of floating signs restricting berthing points**”.
75. Amendments to the Article 4.5.1
- a) Replace the term “signs and signals on the banks” with the “**bank marks**”,
  - b) Replace the term “signs and signals on the water” with the “**floating signs**”

## **V AMENDMENTS TO THE CHAPTER 5**

76. Replace the old Chapter 5 **IMAGE DISPLAY TECHNIQUES** with new one:

### **VARIABLE MESSAGE SIGNS TO REGULATE TRAFFIC**

#### **Article 5.1**

When variable message signs are used to regulate traffic, attention must be paid to the following:

- (a) If variable message signs regulating traffic show images of signs from Annex 7 to NAVIGATION RULES ON THE SAVA RIVER BASIN, the images must be depicted using a mechanical display system. Annexes 1 and 3 are applicable with regard to colour selection and dimensions;
- (b) By night, mechanical display systems shall be externally lit. Annex 4 shall be applicable;
- (c) The use of auto-illumination display systems should be avoided for the signs in Annex 7 to NAVIGATION RULES ON THE SAVA RIVER BASIN. Inverse representation (e.g. inversion of black and white surfaces for prohibitory signs) shall not be allowed;
- (d) A remote controlled auto-illumination matrix display may constitute a reasonable alternative in order to indicate frequently changing information, such as water levels and the height of navigable passages through bridges. Technically, it is possible to display images using light emitting diodes, liquid crystals and light guides;
- (e) By day, there must be sufficient luminosity to ensure the sign can be read; by night, luminosity must be reduced in order to prevent any dazzling and to ensure that the sign can be identified. The image must thus be regulated according to light measurements in the surroundings.

## VI AMENDMENTS TO THE CHAPTER 6

77. Amendments to the title of the Chapter
- a) Amend the title of the chapter as follows “**INSTALLATION OF RADAR REFLECTORS ON MARKING SIGNS AND SIGNALS AND NAVIGABLE PASSES THROUGH BRIDGES**”.
78. Amendments to the Article 6.1
- a) Replace the sentence “Signs on the water and on the banks shall be equipped with radar reflectors to ensure their visibility.” with the following one” **It is important to equip floating** signs and bank marks with radar reflectors to ensure their visibility.”
79. Amendments to the Article 6.2
- a) Replace the second sentence “This distance is not always the same, but depends on the technical characteristics of the radar equipment, the radar reflectors and the specific conditions of the river and the height of the antenna installed on the vessel, as well as the height of the radar reflector in relation to the water.” with the following one” This distance depends on the technical characteristics of the radar equipment, the **reflective capacity of the** radar reflectors and the specific conditions of the river and the height of the antenna installed on the vessel, as well as the height of the radar reflector, **both** in relation to the water **surface**.”
80. Amendments to the Article 6.3
- a) Delete the whole article
81. Amendments to the Article 6.4
- a) Renumber the article to 6.3
  - b) Replace the first sentence “From experience, bridge passages and pillars are not always sufficiently visible on the screen. In order to ensure danger-free passage through bridges, buoys equipped with radar reflectors shall be placed on both sides of the passage, not less than 15-20 metres upstream and downstream from the bridge, or passages through bridges shall be marked with radar reflectors installed on the bridge itself not less than 12-15m from the farthest edge of bridge construction (Figure 15).” with the following one” **Since the visibility of bridge pillars is usually insufficient on radar screens, the bridge pillars for the passage of vessels upstream and downstream must be marked either by buoys equipped with radar reflectors placed not less than 15–20 m before the bridge, or by radar reflectors installed on the bridge itself not less than 12–15 metres from the farthest edge of bridge construction (Fig. 15). A.**”
  - c) Replace the second sentence “The sketch of the recommended radar reflector with minima dimensions is in the Annex I.” with the following one” A sketch of the recommended radar reflector is **contained in section 3.4 of Appendix 1.**”
82. Amendments to the Article 6.5
- a) Renumber the article to 6.4
  - b) Replace the clause “are extremely reliable” with “are “**improve navigation safety**”
83. Amendments to the Article 6.6

- a) Renumber the article to 6.5
84. Amendments to the Article 6.7
- a) Renumber the article to 6.6
- b) Replace the first sentence “In general, when radar reflectors are used on marking signs and signals, the rule that these reflectors shall not modify the form or size of the sign or signal should be observed.” with the following one” **When radar reflectors are used on marking signs and signals, the visibility of the sign must not be diminished.**”
- c) Replace the term “signs and signals in question” with the “**sign** in question”,
85. Amendments to the Article 6.8
- a) Renumber the article to 6.7
- b) Delete the first sentence: “The most common type of radar reflector is the so-called square octahedral reflector, i.e. a reflector with eight cavities.”,
- c) Add a new sentence “**Radar reflectors on fairway buoys are most often manufactured using two vertical metal plates set as a cross, with a horizontal metal plate intersecting them at a right angle.,**
- d) Replace the third sentence “The reflectors should be made of aluminium or stainless steel, and not painted so as to enhance reflectivity.” with the following one” The reflectors should be made of aluminium or stainless steel.”
86. Amendments to the Article 6.9
- a) Renumber the article to 6.8
- b) Replace the second bullet “type 2: tip to tip height 800 mm” with the following one “Type 2: tip-to-tip height 850 mm.”
87. Amendments to the Article 6.10
- a) Renumber the article to 6.9
- b) Replace the first sentence “The square plate referred to above has a diagonal of 300 or 565 mm respectively and sides of 210 or 400 mm respectively.” with the following one”The square plate referred to **in article 6.7** has a diagonal of 300 or 600 mm respectively and sides of 210 or **425** mm respectively.”
- c) Delete the second sentence,



Characters:

For many types of European characters, when using black type on a white background, the maximum readability distance  $D$  — if the observer is positioned at a right angle to the surface of the board — is approximately  $D \approx 465 \times h$ , where  $h$  equals the height of the character (height of capital letters above the line).

Viewed at an angle:

If seen askew, the maximum visibility or readability distance of the board is reduced each time by the cosine of angles  $h$  and  $v$  between the observer and the central perpendicular line:

$$D(h, v) = D_o \cos(h) \cos(v).$$

**Fig. 2**

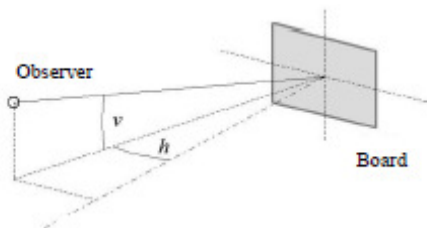

Central perpendicular line

When the observer is at a great distance, the vertical angle shall be considered to be approximately 0:  $v \approx 0$ . In such cases, the following formula can be used as guidance to determine the visibility distance:  $D(h, v) \approx D(h) = D_o \cos(h)$ . The area of visibility is thus a circle with a diameter of  $D_o$ .

**Fig. 3**

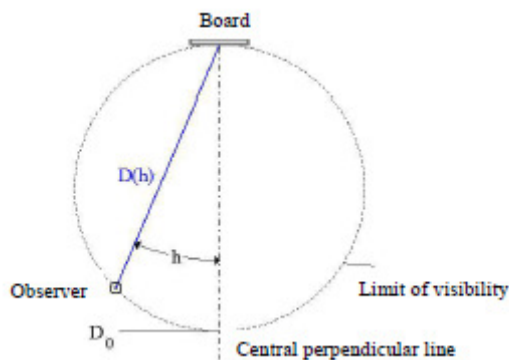

Note: Etude de la perceptibilité des symboles et des inscriptions sur les signaux de navigation (Study of symbol and inscription visibility on navigation signs), Gerdes, paper presented at the 1990 International Conference on Maritime Signs.

90. Amendments to the Section I

- a) Add the following new sketch: A.1.1 (Sections closed to use, no entry except for non-motorized small craft)

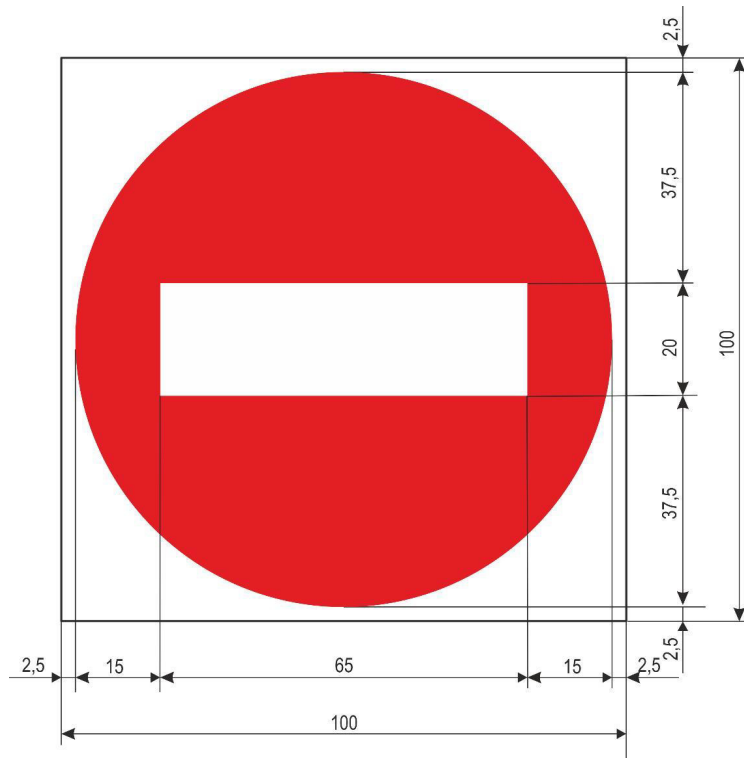

- b) Rename the sign A.5 as follows: No berthing **on the side of the waterway on which the sign is placed**
- c) Rename the sign A.9.a as follows: Do not create wash **likely to cause damage**
- d) Replace the existing sketch A.15 (Sailing vessels prohibited) with the following one (*sail moved on the left side*):

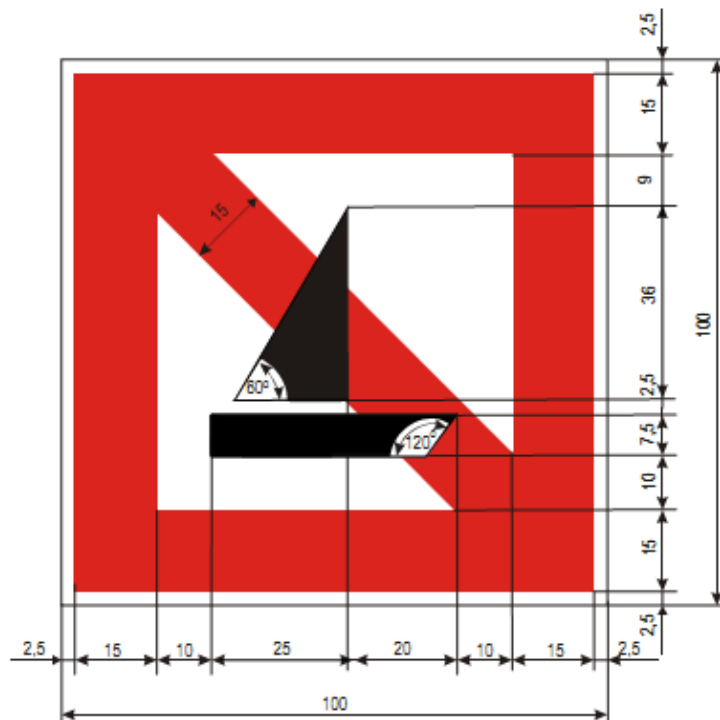



- e) Replace the existing sketch A.16 (All craft other than motorized vessels or sailing craft prohibited) with the following one (**Rower added**):

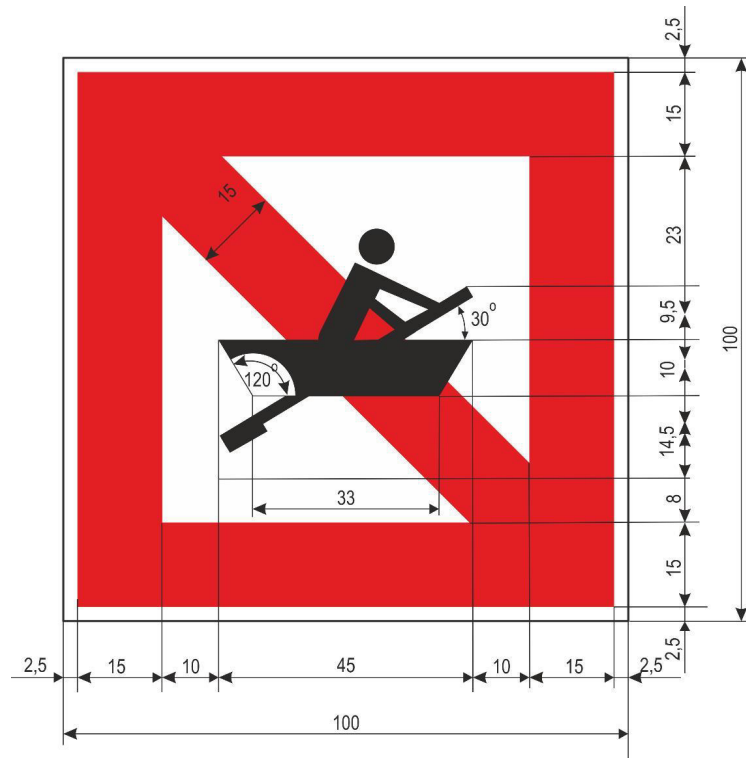

- f) Replace the existing sketch A.19 (No launching or beaching of vessels) with the following one (**slipway moved to the left**):

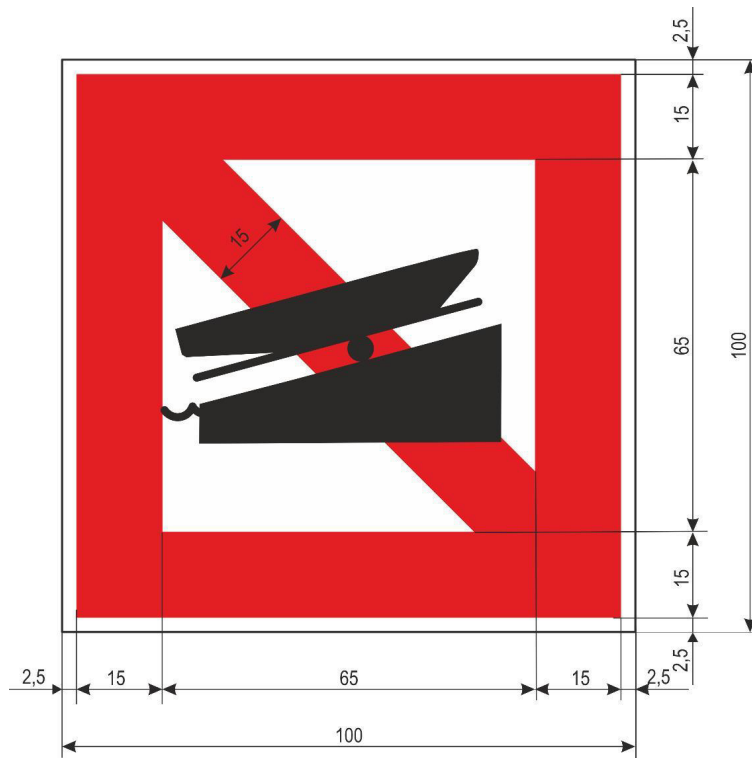

- g) In the sketches of the marks D.1, D.1c and D1.d add the phrase "**black band**" behind the label for the outer stripe thickness 1.0 (cm), as well as the phrase "**white band**" behind the label for the inner stripe thickness 2.5 (cm)
- h) Add the following new sketch: E.6.1 (**Use of spuds permitted**)

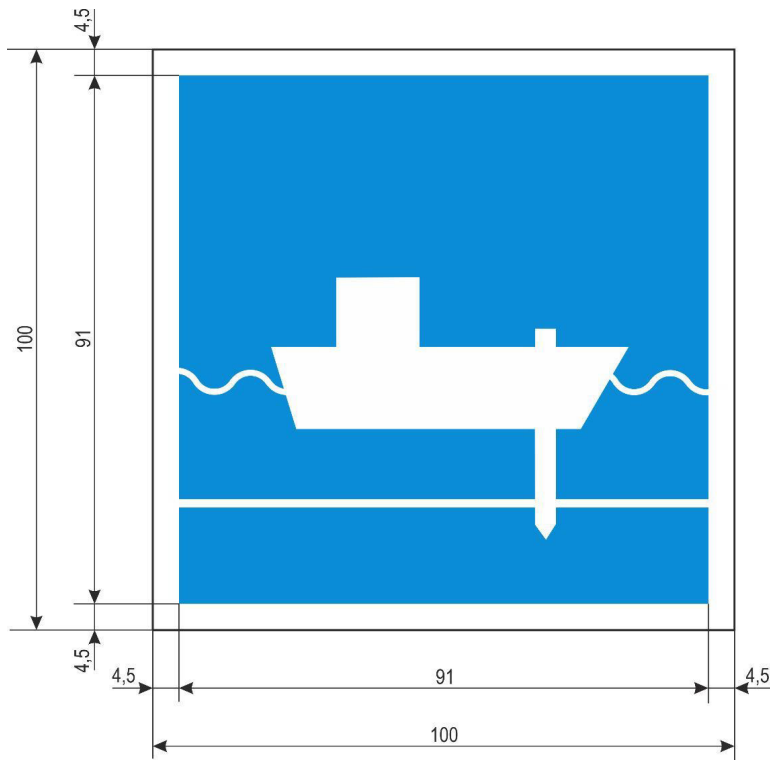

- i) Add the following new sketch: E.9.c (**The waterways being approached are considered to be tributaries of this waterway**):

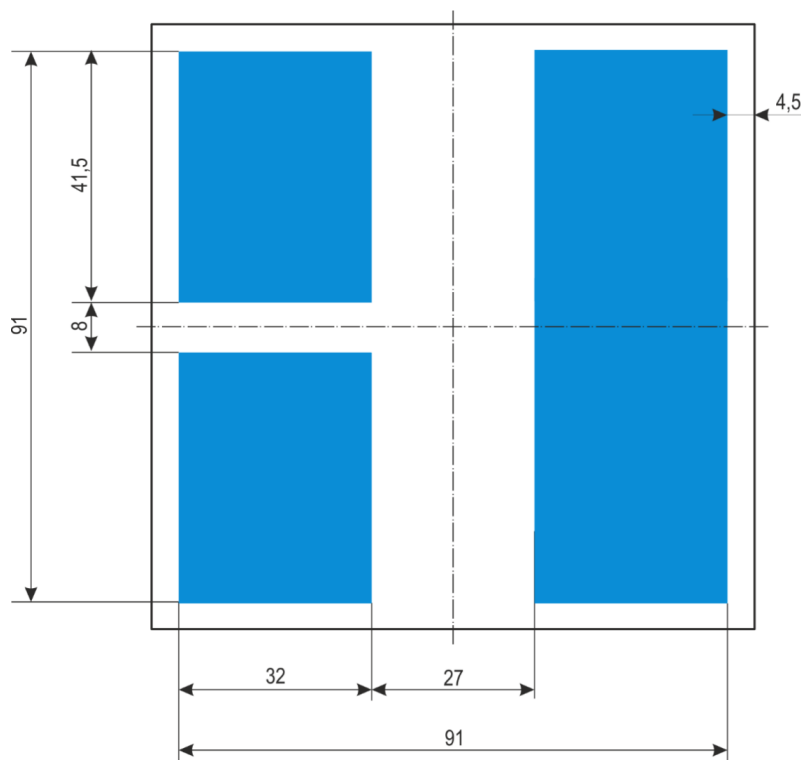

- j) Replace the existing sketch E.19 (No launching or beaching of vessels) with the following one (**Rower added**):

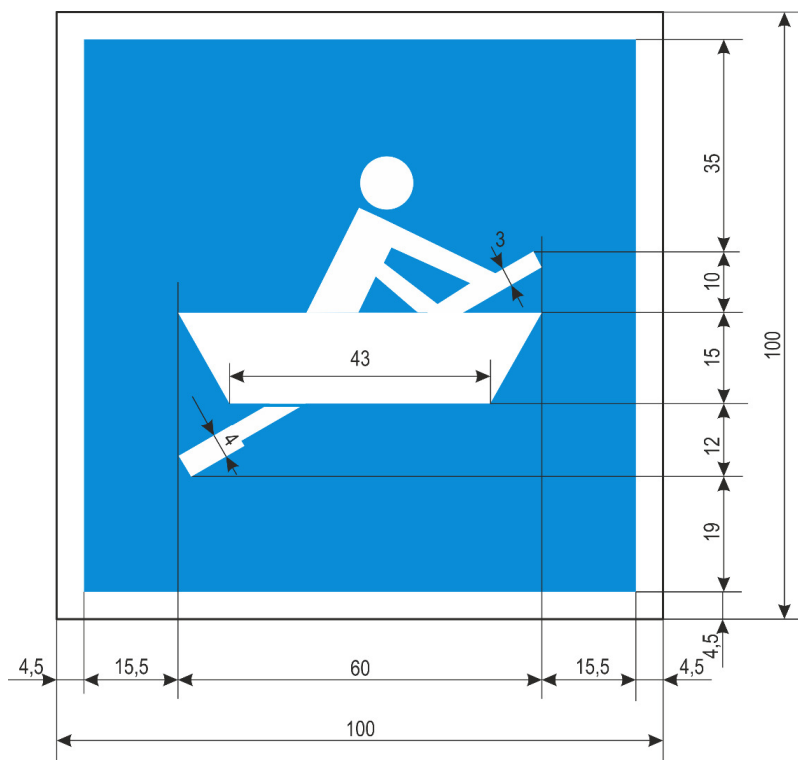

91. Amendments to the Section II

- For the Auxiliary signs add the phrase "**black band**" behind the label for the outer stripe thickness
- Add additional sketch for the bank mark 4.F (Buoyage and marking of danger points and obstacles: right hand side) with the following one:

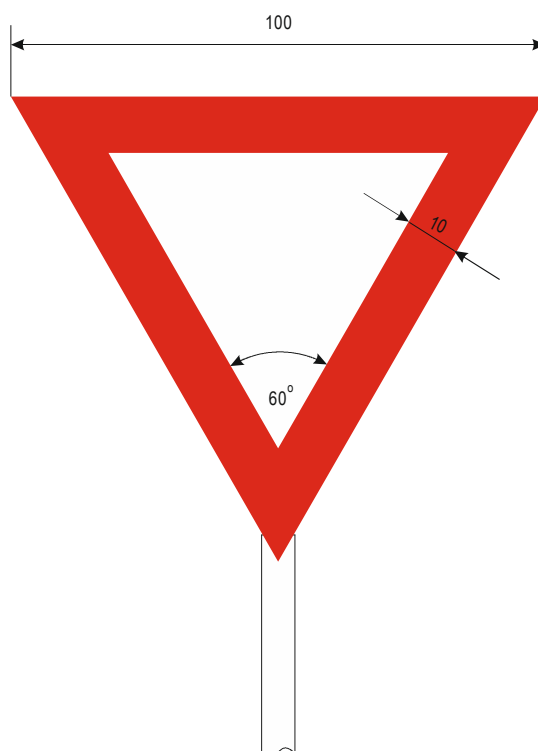

- c) Add additional sketch for the bank mark 5.F (Buoyage and marking of danger points and obstacles: left hand side) with the following one:

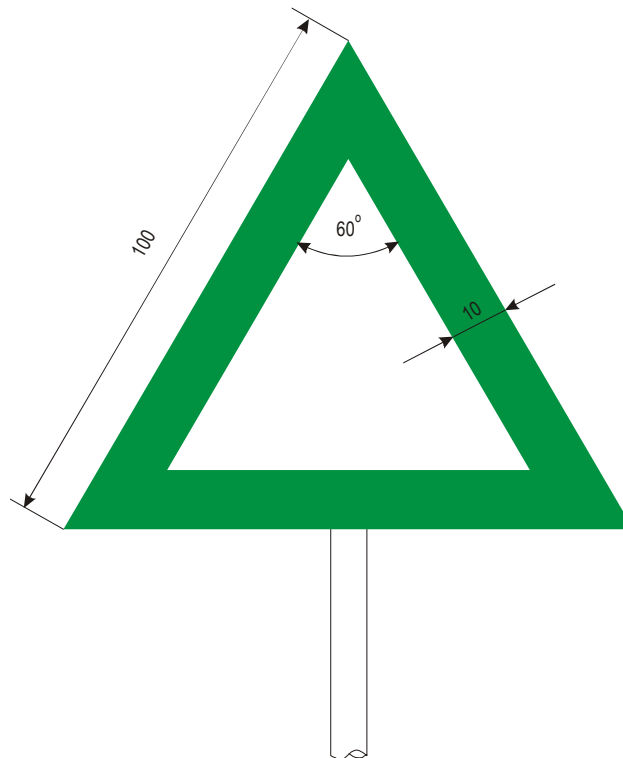

- d) Add additional sketch for the bank mark 6.B (Buoyage and marking of danger points and obstacles: bifurcation without light) with the following one:

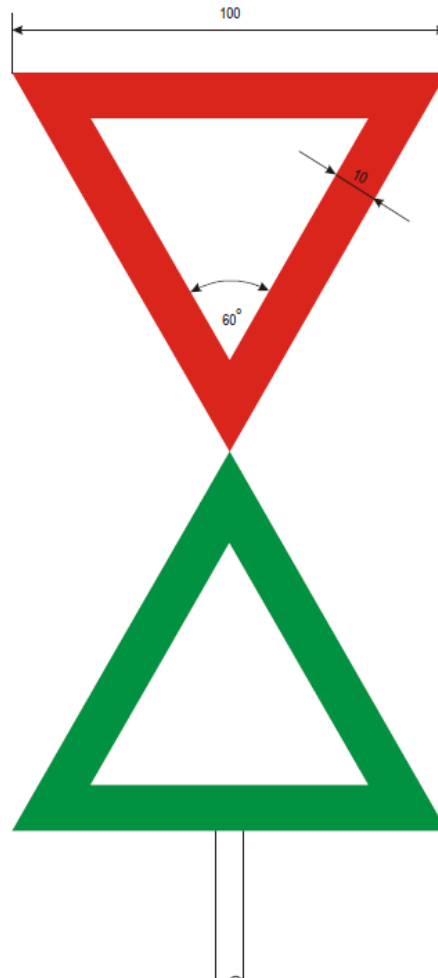

e) Add the following new sketch: 1.F (Right hand side: Red buoy with a spar)

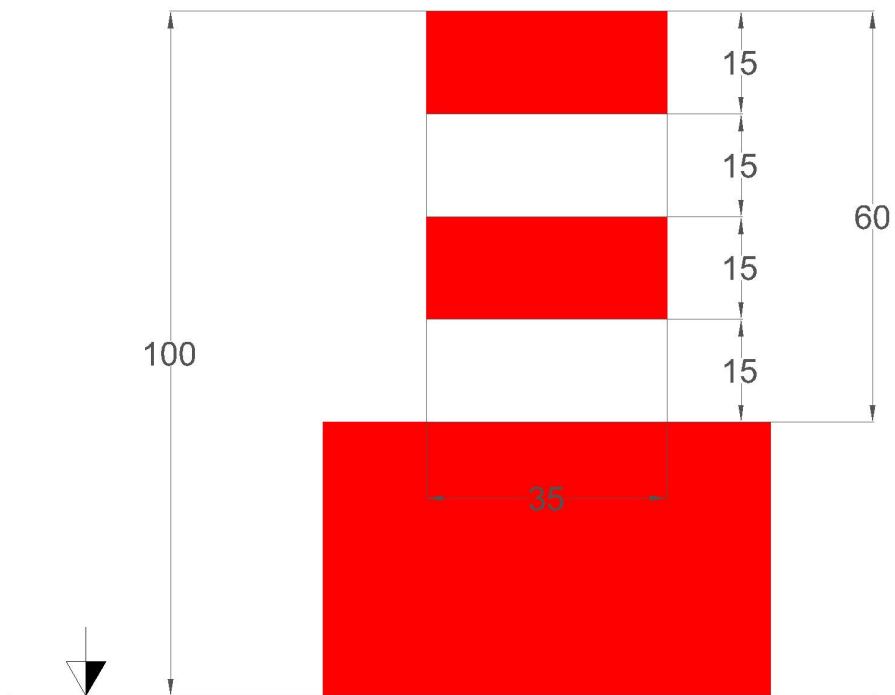

f) Add the following new sketch: 2.F (Left hand side: Green buoy with a spar)

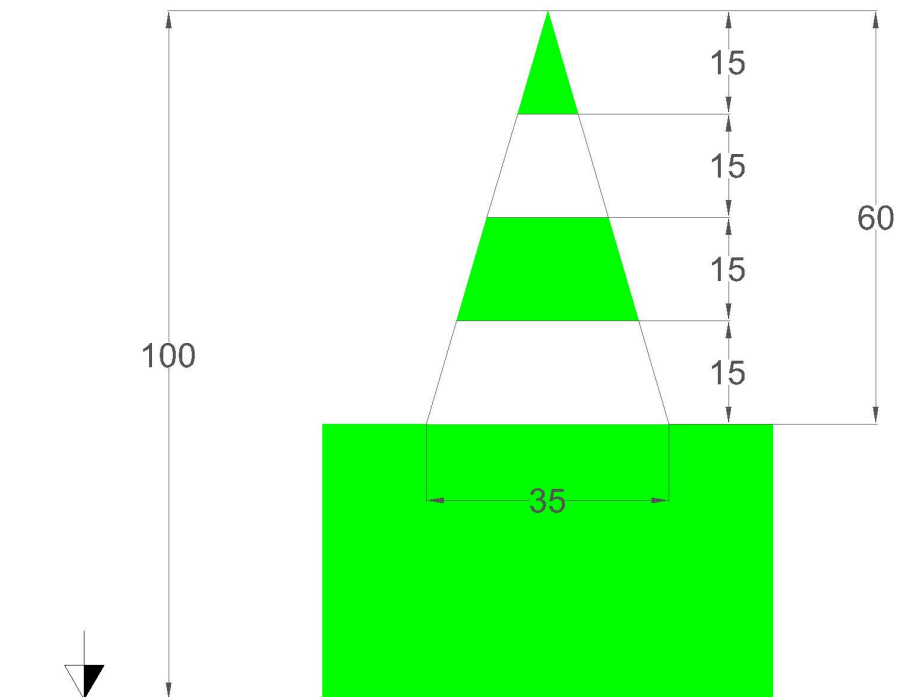

92. Amendments to Annex 2

- a) Replace the whole Annex with the following one:

**PROPERTIES OF LIGHTS**

**1. Categories of luminous intensity**

Lanterns are classified according to their horizontally emitted photometric luminous intensity  $I_{ph}$ , in candelas (cd).  
By analogy with luminous intensity for lights on board vessels, three distinct categories have been established, according to power.

**Table 1**

<i>Category</i>	<i>By analogy with</i>	<i>Intensity of white light [cd]</i>	<i>Intensity of red/green/yellow light [cd]</i>
1	Ordinary light	2–9	0.8–3.5
2	Bright light	9–35	3.5–20
3	Strong light	35–100	20–50

**2. Acceptable colours of lights**

The colours of lights are described in a standard chromatic diagram pursuant to ISO 11664/CIE S 014. The range of colours accepted in the standard chromatic diagram is determined according to standard CIE S 004/E-2001.

The chromatic coordinates for the acceptable ranges are as follows:

**Table 2**

		<i>1</i>	<i>2</i>	<i>3</i>	<i>4</i>
White	x	0.300	0.440	0.440	0.300
	y	0.342	0.432	0.382	0.276
Yellow	x	0.536	0.547	0.613	0.593
	y	0.444	0.452	0.387	0.387
Red	x	0.660	0.680	0.690	0.710
	y	0.320	0.320	0.290	0.290
Green	x	0.009	0.284	0.209	0.028
	y	0.720	0.520	0.400	0.400

The yellow/red/green colour ranges are limited in addition by the curve of the colour spectrum. The ranges of colours are set out in Figure 1.

**Figure 1**

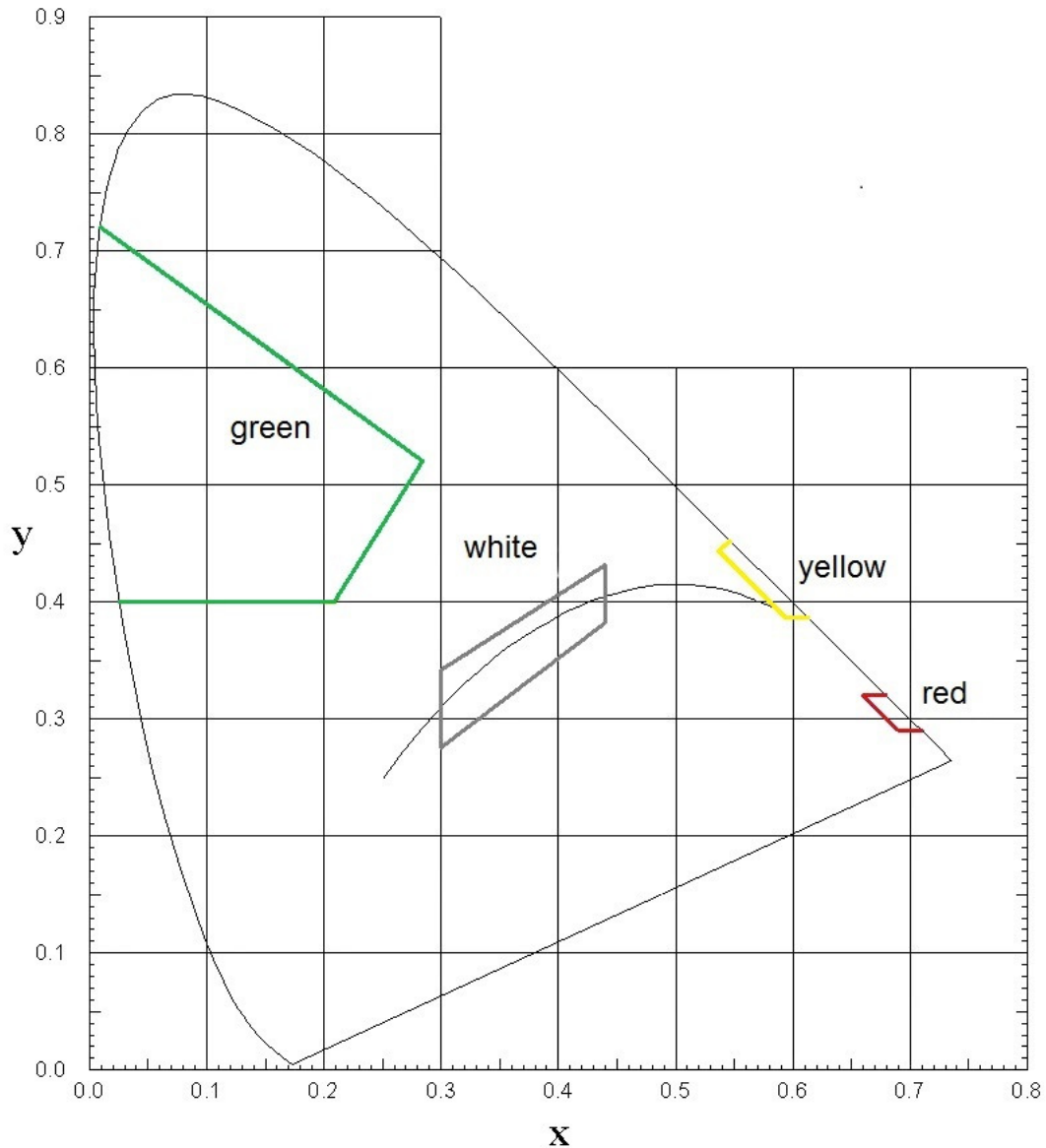

### 3. Calculation of light range

The range of a signal light intended for the guidance of shipping is calculated according to the procedure contained in IALA Recommendation E-200, Part 2 — Calculation, Definition and Notation of Luminous Range, which applies only to signal lights perceived as points by the observer.

Different criteria than those used to establish the range of on-board lights (navigation lights) have been developed for signals intended for the guidance of shipping, which use other values.

The calculations are performed using the following formula:

$$D^2 \times E_t = I_{\text{eff,B}} \times T_M \frac{D}{1852 \text{ m}}$$

Where

$D$  is the range of light;

$I_{\text{eff,B}}$  is the operational luminous intensity of the lantern;

$T_M$  is the value for calculating visibility (describes the atmospheric transmissivity);

$E_t$  is the established limit of luminosity.

The calculation must be done numerically; the formula cannot be solved according to D.

The parameters given are as follows:

$$T_M = 0.6;$$

$$E_t = 2 \cdot 10^{-7} \text{ lx for buoys with lights and simple bank lights with no background lighting;}$$

$$E_t = 10^{-6} \text{ lx to mark a cross-fairway axis with 2 or 3 lights with no background lighting;}$$

$$E_t = 2 \cdot 10^{-6} \text{ lx for all lights with average background lighting (e.g. in a city);}$$

$$E_t = 2 \cdot 10^{-5} \text{ lx for all lights with substantial background light (e.g. industrial facilities).}$$

The operational luminous intensity  $I_{\text{eff,B}}$  is a derivative of the photometric values  $I_{\text{ph}}$  according to the following calculations:

$$I_{\text{eff, B}} = b \times k \times I_{\text{ph}}$$

Where  $b = 0.75$  is the conventionally accepted loss factor owing to dirt and light source degradation.

The effective intensity of rhythmic lights is taken into account by the degree of transmission  $k$ , which is usually calculated according to IALA Recommendation E-200, Part 4 — Determination and Calculation of Effective Intensity.

For the light emitting diodes (LEDs) that are used in most cases and that permit very high frequency commutation, the calculations may be simplified to the following:

$$k = \frac{t}{0,2s + t}$$

Where  $t$  equals the shortest time of light for the rhythm of light used (e.g. 0.5 s for “Fkl. 1s” and 2 sec. for “Glt. 4s”).

**Table 3**

The typical range with visibility  $T_M = 0.6$

<i>Background lighting</i>	<i>No</i>	<i>No</i>	<i>Average</i>	<i>Substantial</i>
<i>Light limit <math>E_t</math> [lx]</i>	$2 \times 10^{-7}$	$10^{-6}$ (marking of the axis)	$2 \times 10^{-6}$	$2 \times 10^{-5}$
<i>Luminous intensity <math>I_{\text{eff,B}}</math> [cd]</i>	<i>Range [m]</i>			
1	1 760	890	650	220
2	2 300	1 200	890	300
5	3 210	1 760	1 320	470
10	4 050	2 300	1 760	650
20	5 010	2 970	2 300	890
50	6 470	4 050	3 210	1 320
100	7 720	5 010	4 050	1 760
200	9 060	6 100	5 010	2 300
500	11 000	9 060	6 470	3 210



93. Add new Annex 3:

**COLOURS OF REFLECTED LIGHT FOR NAVIGATION SIGNS**

The colours of light reflected by navigation signs (day markings) must conform with CIE publication No. 39-2 (TC-1.6) 1983 “Recommendations for Surface Colours for Visual Signalling”.

The following is taken from the Recommendations:

- Ordinary colours of materials (standard colours), in this case: red, yellow, green, blue, white and black;
- Fluorescent colours of materials (luminescent in daylight), in this case: red, green.

The acceptable colours are given in ranges and with a standard chromaticity diagram, specifying as well the requirements for intensity coefficients (luminance factors). The chromaticity coordinates for the ranges and intensity coefficients are shown in Table 1. For colours adjacent to the spectral colour curve, the curve represents their external limit.

**Table 1**

<i>Colour of the reflected light</i>	<i>Intensity coefficient</i>	<i>1</i>		<i>2</i>		<i>3</i>		<i>4</i>	
<i>Standard colours</i>		<i>x</i>	<i>y</i>	<i>x</i>	<i>y</i>	<i>x</i>	<i>y</i>	<i>x</i>	<i>y</i>
Red	> 0.07	0.690	0.310	0.595	0.315	0.569	0.341	0.655	0.345
Yellow	> 0.45	0.522	0.477	0.470	0.440	0.427	0.483	0.465	0.534
Green	> 0.10	0.313	0.682	0.313	0.453	0.209	0.383	0.013	0.486
Blue	> 0.05	0.078	0.171	0.196	0.250	0.225	0.184	0.137	0.038
White	> 0.75	0.350	0.360	0.300	0.310	0.290	0.320	0.340	0.370
Black	< 0.03	0.385	0.355	0.300	0.270	0.260	0.310	0.345	0.395
<i>Colours luminescent in daylight</i>		<i>x</i>	<i>y</i>	<i>x</i>	<i>y</i>	<i>x</i>	<i>y</i>	<i>x</i>	<i>y</i>
Red	> 0.25	0.690	0.310	0.595	0.315	0.569	0.341	0.655	0.345
Green	> 0.25	0.313	0.682	0.313	0.453	0.209	0.383	0.013	0.486

The figure below shows the admissible colour ranges on the standard chromaticity diagram. The ranges for ordinary colours and those that are luminescent in daylight (red/green) are identical; the colours differ only in their intensity coefficients.

**Figure 1**

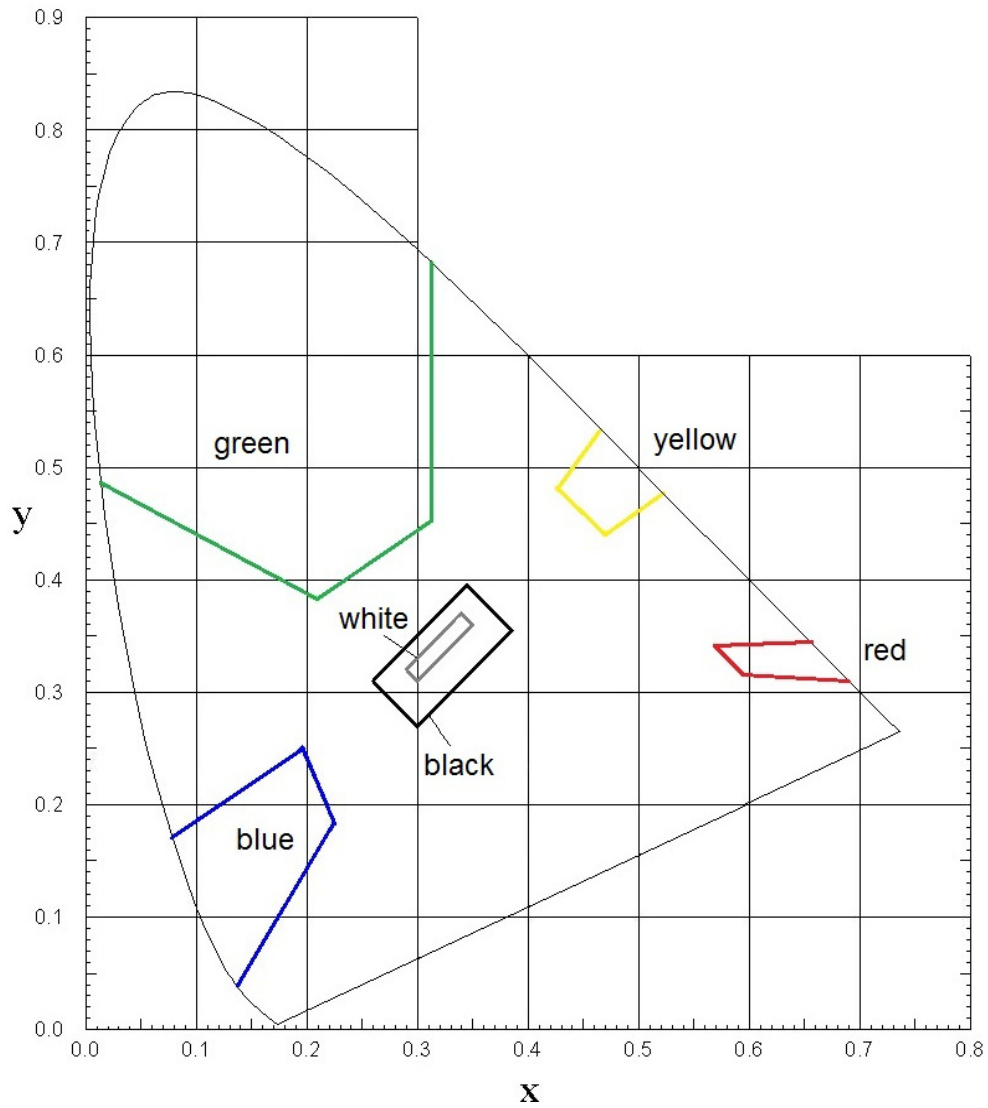

A simplified description of the admissible colours can be presented using the RAL numbers from the internationally recognized RAL-Classic colour system.

The colours below correspond with the CIE Recommendations and are preferred for use in transport technologies.

Table 2

<i>Number</i>	<i>Designation</i>	<i>Recommended use</i>
RAL 1023	Traffic yellow	Traffic signs, buoys
RAL 3020	Traffic red	Traffic signs
RAL 3024	Luminous red	Buoys, strongly visible traffic signs
RAL 3028	Pure red	Buoys, sufficiently visible traffic signs
RAL 5017	Traffic blue	Traffic signs
RAL 6024	Traffic green	Traffic signs
RAL 6037	Pure green	Buoys, sufficiently visible traffic signs
RAL 6038	Luminous green	Buoys, strongly visible traffic signs
RAL 9016	Traffic white	Traffic signs, buoys
RAL 9017	Traffic black	Traffic signs, buoys

It is recommended that navigation sign surfaces, when they are not a part of the signs themselves, should be RAL 7042 traffic grey A or RAL 7043 traffic grey B.

It may be advisable to use adhesive light-reflective films on markers that are not equipped with lights. For the colours of light-reflective films, reference may be made to the relevant international standards for road transport.

94. Add new Annex 4:

## RECOMMENDATIONS FOR THE LIGHTING OF TRAFFIC SIGNS

### 1. General provisions

The lighting shall be turned on only at night. During daytime, the sign must be identifiable with natural lighting. The lighting may be arranged either with an external, backward-facing floodlight located in front of the sign or with lighting from the inside of translucent panels (internally backlit signs) as shown in Fig. 1.

Figure 1

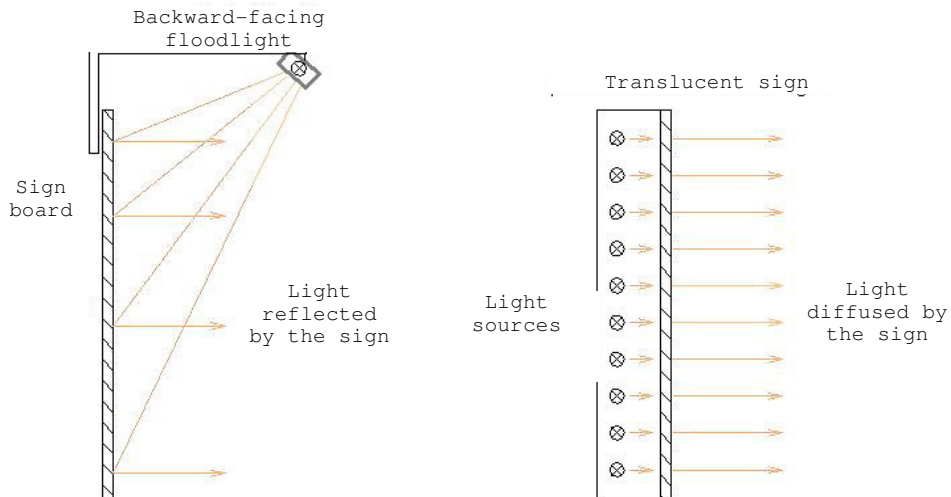

### 2. External backward-facing lighting

External backward-facing lighting from a floodlight located above the sign is generally arranged with floodlights affixed above or below the sign board. For tall signs it is advisable to affix two floodlights (above and below). For wide signs it is possible to affix several floodlights in a line.

To avoid undesirable dark spots and glare, the floodlights must be located in such a way that they do not block a view from an angle of 7 degrees from the horizontal, drawn from the sign's top or bottom edge.

**Figure 2**

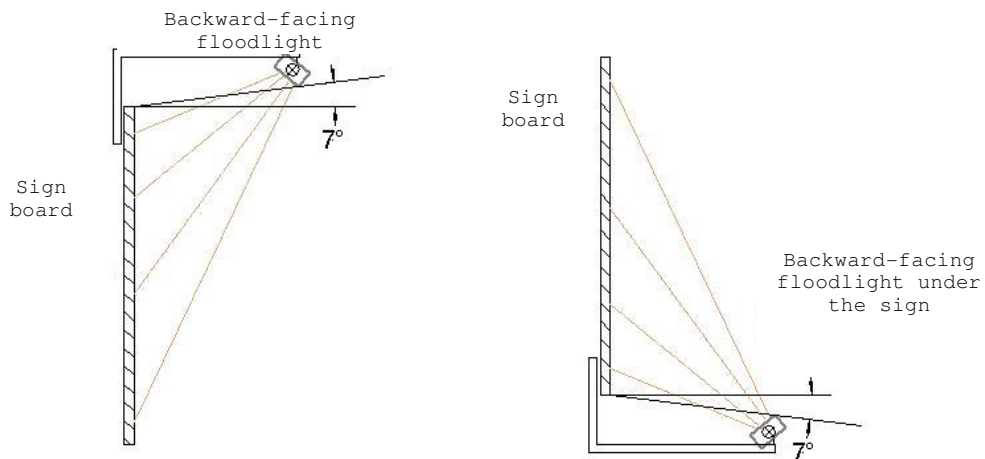

The type of lighting is always determined by the readability of the sign illuminated by the backward-facing light. Minimum dimensions are given in Appendix 1 to these Guidelines.

With some boards, the illuminated surface is identical to the board itself. If several boards conveying a single message are installed, for instance with additional text plates, the lighting requirements refer to the overall surface of the combined boards.

Fig. 3 shows the recommended dimensions of the backward-illuminated surface of a sign board:

- (c) standalone;
- (d) with an additional plate.

**Figure 3**

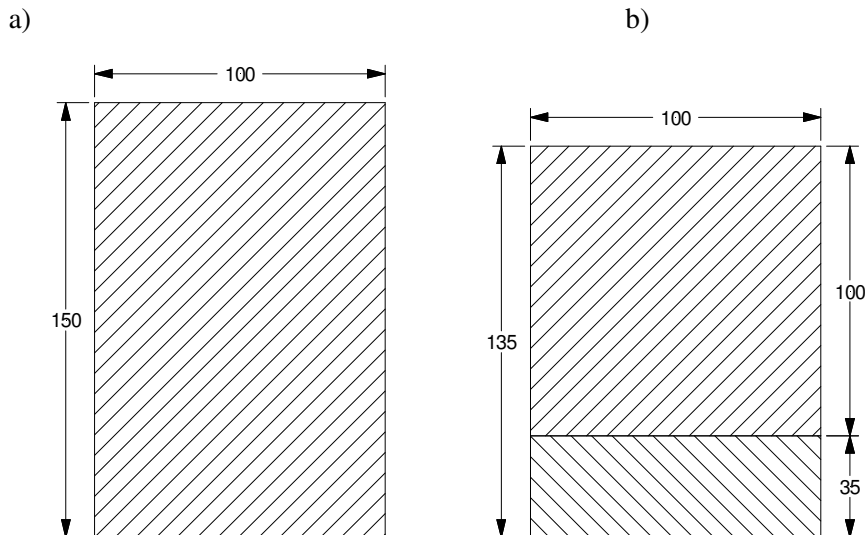

As for the backward-illuminated surface, the following lighting parameters are recommended:

- in areas with insignificant background light levels (for example, outside of city limits), the luminosity measured on-site should range from 40 lx to 100 lx.
- in areas with increased background light levels (for example, within city limits), the luminosity measured on-site should range from 100 lx to 400 lx.

The uniformity of lighting is established by the ratio between the minimum luminosity ( $E_{min}$ ) and the maximum luminosity ( $E_{max}$ ) on the back-illuminated surface. In all cases the ratio must be greater than or equal to 1:10 ( $E_{min}:E_{max} \geq 1:10$ ).

For the lighting, a white lamp with a colour temperature between 3500 K and 4500 K is used. Care must be taken to ensure that the sign colours are reproduced when the backward-facing light is white.

### **3. Internally backlit signs**

It is recommended to use intensity class L1 for signs in areas with insignificant background light and intensity class L2 for those with increased background light levels.

As for the uniformity of the lighting, the aim should be to reach class U1 (1:10).

95. Add new Annex 5:

## EXAMPLES FOR VARIABLE-MESSAGE TRAFFIC SIGNS

### 1. Mechanical boards

#### A. Scrolling sign boards

Boards with a scrolled band of sign images are useful as variable message traffic signs, in particular for displaying the signs in annex 7 to CEVNI.

The sign images are placed on a band that is scrolled vertically on rollers. The rollers place the currently valid image in the window for display.

Figure 1

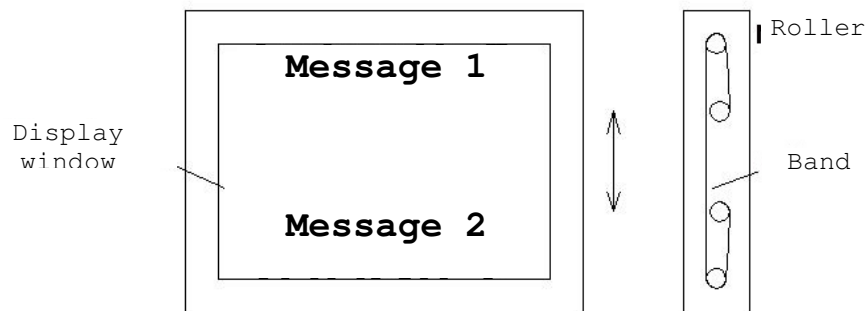

The advantage of scrolling sign boards is that they make it possible to display a large number of signs.

For numerical displays (water levels, cross currents), each digit is displayed using a pile of split flaps capable of representing the numbers from 0 to 9.

#### B. Trivion boards

Trilon boards are used preferably to display two different signs from annex 7 to CEVNI. This technique is limited to displaying three distinct sign images. Generally, the third position is reserved as blank, with a gray surface.

Figure 3

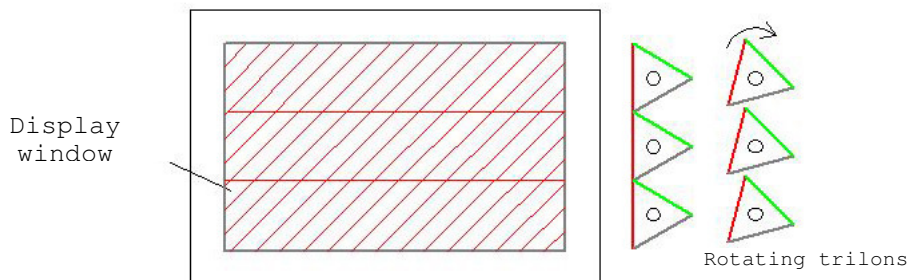

In comparison with boards using scrolling bands, the advantage of trilons is that they are mechanically more robust. At the same time, it is not necessary to produce sign images on a flexible surface, which makes it possible to use paints and films of proven value for use on navigation signs.

#### C. Other mechanical boards

There are many mechanical systems for information boards (for example, including flip-disk boards), with many designed for use in indoor spaces (such as transport terminals or stations). For navigation signs, which generally have to bear the brunt of weather conditions, the service life of such systems is often negligible; they often require servicing.

## 2. Electronic boards

Purely electronic systems for information boards have the basic advantage of incorporating absolutely no moving parts. The ones that are best known are boards using LEDs, liquid crystals or optical fibres.

Such messages are displayed as white or yellow digits or letters on a black background.

During manufacture, the characters are converted into groups of constituent dots to ensure that they can be read.

While mechanical boards are visible with natural light during daylight hours, electronic boards emit light both day and night.

At the same time, a contrasting frame is required, the aim being to reduce the so-called phantom effects caused by sunlight. Reflection angles must be sufficiently large to reliably eliminate reflections on the fairway segments in question.

As a direct consequence, electronic boards consume significantly more energy than mechanical ones.

At the same time, in daylight, the boards must be sufficiently luminous so that their messages can be seen even in clear and sunny weather. At night, they must be darkened so as to avoid unwanted brightness or dazzle.

Adjustments are made by measuring the background luminous intensity and adapting the intensity of the board accordingly<sup>17</sup>.

The boards' reflection angles should also be observed<sup>18</sup>.

For horizontally illuminated sectors there are classes with ranges up to  $\pm 30^\circ$  ( $60^\circ$ ). Technically, it is possible to display sectors ranging up to  $\pm 60^\circ$  ( $120^\circ$ ) at an acceptable cost.

### A. Optical waveguide (optical fibre) boards

Optical fibre boards have been used for many years on variable message road traffic signs (for example, to display temporary speed limits). The sign's image is divided into distinct points of light, with each point backlit by an optical fibre.

When a digit is displayed, the optical fibres of the digit in question are grouped and backlit with a lamp. For each digit there is thus a separate lamp, and each point of light can be used for just one digit. The points thus cannot be individually controlled. Each image must in turn have a source lamp.

#### Figure 3

Depiction of light points corresponding with lamps for two digits (for clarity, only some of the optical fibres are shown)

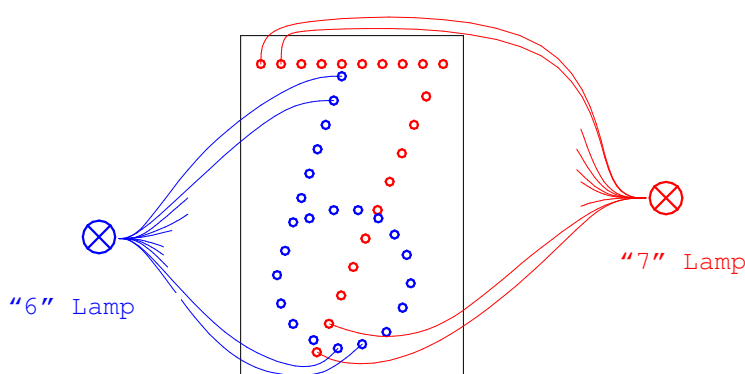

In recent years, optical fibre boards have to a great extent been replaced by LED matrix boards.

<sup>17</sup> If standard EN 12966-1 is used for this purpose, the adjustment coefficient (the board's maximum-to-minimum luminosity ratio) exceeding 100:1 is applied.

<sup>18</sup> The luminance classes described in standard EN 12966-1 are intended for road traffic and would presuppose that the boards are installed at least as high as the maximum height of a bridge allowing for navigation.



## B. Light-emitting diode (LED) matrix boards

In the case of a LED matrix, each separate point of the image is displayed by a diode that can be independently turned on and off. In principle, such boards can be freely programmed (using a complete matrix), thus making it possible to display any message.

**Figure 4**

Individually controlled light emitting diodes displaying digits



Often, though, only seven segments required to display digits are connected.

As fewer diodes are used, the electronic control is simplified, which results in savings. To reduce costs, it is possible to pre-programme groups of LEDs to display only the messages that are required.

**Figure 5**

Board composed of seven segments with separate light emitting diodes

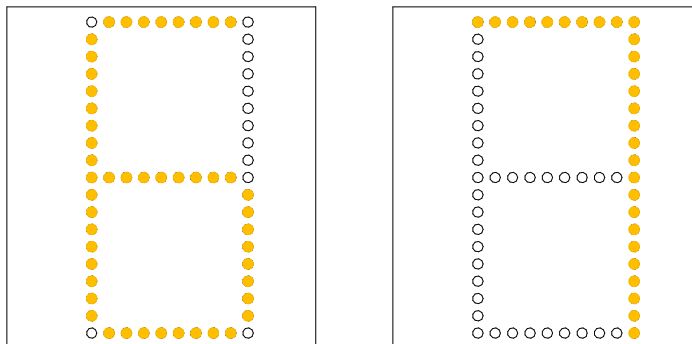

## C. Liquid crystal displays (LCDs)

Boards using liquid crystal displays (LCDs) are composed of a regularly illuminated surface placed behind a film of liquid crystals, which blocks areas of the image, thus creating the desired figure. For large boards, monochrome images are preferred, although colour images are possible as well. Diodes have recently been employed to backlight the surface, while fluorescent lamps were previously used.

The advantage of this kind of board is that it produces a very sharp, detailed image, with such high luminosity and contrast that the boards can be used in daylight.

There is a technical disadvantage, though, as the optical characteristics of the liquid crystal film are such that only a small part (less than 25 per cent) of the generated light is displayed. For the same luminosity, boards of this kind require significantly more power than those using LED matrices.

What is more, because liquid crystal displays are extremely sensitive to temperature changes and humidity, they must be protected, which involves high costs.